



AIR SPRINGS SUPER CUSHION



GOOD YEAR
ENGINEERED PRODUCTS

VEYANCE
TECHNOLOGIES

VEYANCE DE MÉXICO S. de R.L. de C.V.



SUSPENSIONES NEUMATICAS, CARACTERISTICAS Y BENEFICOS

Gran Nivel de Aislamiento

- Reduce la necesidad de mantenimiento a instrumental eléctrico/electrónico de la unidad
- Reduce daños a la cabina y en general a la unidad
- Reduce el desgaste de los ejes, transmisión y las llantas
- Reduce el tiempo de servicio
- Extiende la vida útil de la unidad
- Reduce los daños por fatiga al vehículo

Para el dueño de la unidad, la suspensión neumática

- Mejora el aislamiento en condiciones de carga completa y sin carga
- Amplia la gama de carga disponibles para la transportación, incluyendo equipo electrónico, donde la suspensión neumática reduce daños a la carga.
- Gran confort al operador
- Incrementa el valor de reventa de la unidad protege bisagras, remaches, luces y todos los accesorios del remolque

Razones para aumentar el uso de la suspensión neumática

- Los fabricantes de suspensión le han incorporado un mayor grado de durabilidad, por lo tanto ofrecen períodos de garantía más largos.
- Incrementa la implementación del eje retráctil

No. Competidor	No. Goodyear EP	No. Competidor	No. Goodyear EP	No. Competidor	No. Goodyear EP	No. Competidor	No. Goodyear EP
AMERICAN CARRIER		990671	1R10-087	FD200-19448	2B9-280	FD330-22318	2B12-307
Air Spring Bellows		BOSTROM		FD200-19450	2B9-230	FD330-22327	2B12-300
8003-005	2B14-355	AIR SPRING SLEEVE		FD200-19452	2B9-246	FD330-22331	2B12-406
8003-006	2B8-550	1201542-01	1S4-196	FD200-19499	2B9-201	FD330-22334	2B12-320
8003-007	1B14-351	1108707-001	1S4-197	FD200-19504	2B9-288	FD330-22343	2B12-427
AMERICAN CARRIER		CHANCE BUS		FD200-19505	2B9-229	FD330-22346	2B12-410
Air Spring Rolling Lobe		Air Spring Rolling Lobe		FD200-19510	2B9-245	FD330-22363	2B12-425
8003-003	1R11-171	23891728	1R11-152	FD200-22524	2B10-226	FD330-22364	2B12-313
8003-023	1R11-161	CONTITECH		FD200-22706	2B9-229	FD330-22365	2B12-426
AUTO BUS		Air Spring Bellows		FD200-25426	2B9-250	FD330-22367	2B12-319
Air Spring Rolling Lobe		FD110-15766	2B6-535	FD200-25427	2B9-253	FD330-22368	2B12-432
10530087	1R10-089	FD120-20509	2B8-550	FD200-25428	2B9-255	FD330-22465	2B12-432
BLUEBIRD		FD200-19310	2B9-239	FD200-25429	2B9-251	FD330-22471	2B12-412
Air Spring Rolling Lobe		FD200-19315	2B9-206	FD200-25453	2B9-218	FD330-22472	2B12-411
1286814	1R11-151	FD200-19320	2B9-200	FD200-25454	2B9-266	FD330-22500	2B12-304
12TA-1-2	1R12-095	FD200-19362	2B9-210	FD200-25463	2B9-254	FD330-22540	2B12-463
300-961250	1R12-095	FD200-19448	2B9-252	FD330-22313	2B12-309	FD330-22780	2B12-429
		FD200-19448	2B9-265				

No. Competidor	No. Goodyear EP	No. Competidor	No. Goodyear EP	No. Competidor	No. Goodyear EP	No. Competidor	No. Goodyear EP
FD330-30323	2B12-305	FT530-32333	3B14-360	11105C-16A3	1R14-147	910-14P461	1R12-325
FD330-30340	2B12-324	FT530-32336	3B14-354	11105C-16A7	1R14-039	910-14P462	1R12-438
FD330-30369	2B12-416	FT530-35441	3B14-452	11105F-17P74	1R14-172	910-14P465	1R12-620
FD330-30369	2B12-446	FT530-35455	3B14-364	11105F-17P74	1R14-190	910-14P469	1R12-434
FD330-30370	2B12-402	FT530-35456	3B14-451	64382	1R12-663	910-14P709	1R12-285
FD330-30371	2B12-434	FT530-35457	3B14-367	64761	1R12-613	910-16374M	1R12-014
FD330-30372	2B12-428	CONTITECH		910-10P311	1R12-095	910-16P310	1R12-092
FD330-30464	2B12-434	Air Spring Rolling Lobe		910-10P328	1R12-351	910-16P310	1R12-509
FD330-30502	2B12-317	1010-15P453	1R13-159	910-10P331	1R12-359	910-16P325	1R12-155
FD330-30513	2B12-324	1010-15S518	1R13-097	910-10P339	1R12-350	910-16P325	1R12-358
FD331-26480	2B12-440	1010-15S522	1R13-124	910-10P397	1R12-561	910-16P332	1R12-621
FD331-26514	2B12-345	1010-15S711	1R13-124	910-10P398	1R12-560	910-16P333	1R12-066
FD331-26541	2B12-346	1010-15S871	1R13-109	910-10P399	1R12-559	910-16P350	1R12-092
FD530-22311	2B14-360	1010-16S783	1R13-039	910-10P400	1R12-558	910-16P352	1R12-356
FD530-22316	2B14-359	1010-16S526	1R13-177	910-10P471	1R12-435	910-16P353	1R12-130
FD530-22321	2B14-356	1010-16S533	1R13-176	910-10P480	1R12-556	910-16P372	1R12-220
FD530-22342	2B14-355	1010-16S724	1R13-155	910-10P482	1R12-435	910-16P376	1R12-143
FD530-22345	2B14-367	1010-21P434	1R13-118	910-10P503	1R12-557	910-16P391	1R12-441
FD530-22374	2B14-354	1010-21P486	1R13-153	910-10P542	1R12-555	910-16P393	1R12-567
FD530-30449	2B14-366	1010-21P570	1R13-152	910-12A319	1R12-132	910-16P407	1R12-090
FD530-30451	2B14-365	10105-15P460	1R13-159	910-12A327	1R12-309	910-16P408	1R12-182
FD530-30532	2B14-462	1010B-13S51	1R13-130	910-12A329	1R12-355	910-16P409	1R12-188
FD530-35530	2B14-383	11105-15A414	1R14-037	910-12A341	1R12-132	910-16P410	1R12-365
FD530-35543	2B14-476	11105-15A415	1R14-038	910-12A343	1R12-132	910-16P416	1R12-400
FD530-35544	2B14-470	11105-15A422	1R13-120	910-12A427	1R12-367	910-16P449	1R12-615
FD530-35720	2B14-462	11105-17A316	1R14-028	910-12A488	1R12-487	910-16P497	1R12-436
FS330-11468	1B12-301	11105-17A364	1R14-026	910-12A504	1R12-132	910-16P710	1R12-366
FS530-14339	1B14-358	11105-17A365	1R14-018	910-12P319	1R12-132	910-16P769	1R12-541
FS530-14442	1B14-350	11105-17A366	1R14-028	910-12P329	1R12-355	910-16P770	1R12-576
FS530-14446	1B14-351	11105-17A367	1R14-115	910-12P395	1R12-505	910-16S374	1R12-047
FS530-14447	1B14-351	11105-17A377	1R14-160	910-12P484	1R12-508	910-175A802	1R12-494
FT330-29413	3B12-319	11105-17A405	1R14-159	910-12P488	1R12-487	910-175P406	1R12-424
FT330-29431	3B12-300	11105-17A507	1R14-130	910-12P495	1R12-571	910-175P428	1R12-498
FT330-29432	3B12-301	11105-19A431	1R14-137	910-12P544	1R12-563	910-175P429	1R12-481
FT330-29434	3B12-303	11105-21A313	1R13-038	910-135S433	1R13-119	910-175P436	1R12-366
FT330-29466	3B12-310	11105-21A313	1R14-045	910-135S881	1R13-119	910-175P440	1R12-403
FT330-29469	3B12-300	11105-21A318	1R14-030	910-14A330	1R12-370	910-175P443	1R12-502
FT330-29498	3B12-301	11105-21A369	1R14-019	910-14A469	1R12-434	910-175P445	1R12-586
FT330-29503	3B12-304	11105-21A370	1R14-019	910-14A496	1R12-437	910-175P451	1R12-404
FT330-29508	3B12-312	11105-22A530	1R14-174	910-14A545	1R12-445	910-175P454	1R12-499
FT330-29520	3B12-335	11105-22A752	1R14-170	910-14A575	1R12-636	910-175P456	1R12-538
FT330-29525	3B12-312	11105-22S712	1R14-127	910-14A707	1R12-512	910-175P502	1R12-504
FT330-29546	3B12-328	11105-22S750	1R14-113	910-14AT75	1R12-543	910-175P519	1R12-403
FT330-29547	3B12-315	11105-22S764	1R14-113	910-14P312	1R12-069	910-175P520	1R12-402
FT330-29547	3B12-329	11105A-16P5	1R14-171	910-14P312	1R12-669	910-175P521	1R12-401
FT330-29723	3B12-335	11105C-16A3	1R14-039	910-14P345	1R12-352	910-175P548	1R12-532
FT530-32325	3B14-359	11105C-16A3	1R14-042	910-14P345	1R12-421	910-175P571	1R12-554
FT530-32329	3B14-356			910-14P450	1R12-205	910-175P572	1R12-552



EQUIVALENCIAS PARA AIR SPRINGS

No. Competidor	No. Goodyear EP
910-175P573	1R12-553
910-175P574	1R12-484
910-175P574	1R12-486
910-175P714	1R12-486
910-175P715	1R12-485
910-185P406	1R12-424
910-185P440	1R12-403
910-185P451	1R12-404
910-185P456	1R12-538
910-185P519	1R12-403
910-185P520	1R12-402
910-185P521	1R12-401
910-195P801	1R12-467
910-19A358	1R12-281
910-19A552	1R12-613
910-19A801	1R12-467
910-19A830	1R12-467
910-19Pxxx	1R12-261
910-19P315	1R12-103
910-19P321	1R12-281
910-19P326	1R12-167
910-19P355	1R12-395
910-19P356	1R12-145
910-19P358	1R12-281
910-19P384	1R12-480
910-19P390	1R12-265
910-19P390	1R12-446
910-19P435	1R12-375
910-19P438	1R12-195
910-19P439	1R12-357
910-19P444	1R13-070
910-19P470	1R12-439
910-19P472	1R12-568
910-19P762	1R12-534
910-21A361	1R12-335
910-21A505	1R12-256
910-21P360	1R12-363
910-21P361	1R12-335
910-21P448	1R12-580
910-21P505	1R12-256
910-21P817	1R12-609
910B-175A32	1R13-117
910B-195P88	1R12-432
910D-21A324	1R13-115
910D-21A363	1R13-116
910S-16A382	1R12-303
910S-16A382	1R12-603
910S-16P382	1R12-303

No. Competidor	No. Goodyear EP
99-10P538	1R11-222
99-10P576	1R11-221
99-10P862	1R11-220
99-12P314	1R11-028
99-12P379	1R12-178
99-12P401	1R11-204
99-12P447	1R11-202
99-12P464	1R11-149
99-12P477	1R11-200
99-12P478	1R11-201
99-12P479	1R11-159
99-12P479	1R11-203
99-12P515	1R11-242
99-12P516	1R11-205
99-12P563	1R11-150
99-12P705	1R11-171
99-14A322	1R11-018
99-14A337	1R11-039
99-14A337	1R11-121
99-14A517	1R11-191
99-14P517	1R11-191
99-14P708	1R11-179
99-14P895	1R11-178
99-9P860	1R11-219
99K-15P417	1R11-166
99K-15P424	1R10-120
99K-15P425	1R10-122
99K-15P708	1R11-179
CONTITECH	
AirSpring Sleeve	
SZ70-5060P0	1S4-123
SZ70-5067	1S4-044
SZ70-7065P0	1S45-121
SZ70-8077P0	1S5-057
DAYNA/SPICER	
Air Spring Rolling Lobe	
SR1VA101	1R13-174
SR1VA101-1	1R13-188
SR1VA105	1R13-188
DAYTON	
Air Spring Bellows	
354-6801	2B14-365
354-6803	2B14-366
354-6902	2B9-201
354-6905	2B9-206
354-6910	2B9-200
354-6947	2B9-255

No. Competidor	No. Goodyear EP
354-7112	1B14-358
354-7123	2B14-367
354-7135	2B14-360
354-7136	2B14-356
354-7140	2B14-359
354-7145	2B14-354
354-7146	2B14-355
354-7181	2B12-411
354-7183	2B12-412
354-7400	2B12-309
354-7403	2B12-307
354-7404	2B12-410
354-7405	2B12-313
354-7406	2B12-426
354-7409	2B12-319
354-7410	2B12-406
354-7424	2B12-300
354-7429	2B12-427
354-7437	2B12-320
354-7443	2B12-305
354-7446	2B12-402
354-7447	2B12-324
354-7798	3B14-356
354-7800	3B14-360
354-7818	3B14-359
354-7847	3B14-367
354-8008	3B12-300
Air Spring Rolling Lobe	
352-8050	1R14-039
352-9039	1R12-095
352-9053	1R12-309
352-9069	1R12-069
352-9069	1R12-669
352-9073	1R11-018
352-9082	1R12-092
352-9082	1R12-509
352-9083	1R12-066
352-9096	1R12-358
352-9098	1R12-014
352-9098	1R12-047
352-9101	1R12-103
352-9105	1R12-132
352-9121	1R13-039
352-9122	1R13-038
352-9130	1R12-281
352-9148	1R14-026
352-9149	1R14-018
352-9158	1R14-030

No. Competidor	No. Goodyear EP
352-9177	1R14-028
352-9194	1R12-356
352-9200	1R14-038
352-9203	1R12-395
352-9213	1R12-090
352-9215	1R14-037
352-9238	1R12-145
352-9321	1R12-261
352-9415	1R11-018
352-9422	1R11-028
DINA	
Air Spring Bellows	
A-8127-19	2B9-200
AZ-8127-19	2B9-216
DINA	
Air Spring Rolling Lobe	
2027911C1	1R12-369
224-B020018	1R13-133
224-B020020	1R11-143
224-B020030	1R10-099
E-Z RIDE	
Air Spring Bellows	
8030120	2B9-206
8030150	2B12-324
8030160	2B14-365
8030170	3B14-354
8030180	3B14-359
8030190	2B12-425
E-Z RIDE	
Air Spring Rolling Lobe	
8030192	1R12-309
FAB TEK	
Air Spring Bellows	
40080	2B12-309
FAB TEK	
Air Spring Rolling Lobe	
101827	1R12-095
101828	1R12-092
101828	1R12-509
10828	1R12-309
FREIGHTLINER	
AIR SPRING SLEEVE	
18-40977-000	1S5-175
18-29919-000	1S5-176
FIRESTONE	
AIR SPRING SLEEVE	

No. Competidor	No. Goodyear EP	No. Competidor	No. Goodyear EP	No. Competidor	No. Goodyear EP	No. Competidor	No. Goodyear EP
7205/ 7215/ 7207	1S5-175	6943	2B9-250	7550	2B12-346	5770	1R10-101
7206/ 7202	1S5-176	6944	2B9-252	7555	2B12-440	5779	1R12-303
3000	1S3-013	6945	2B9-253	7557	2B14-383	8058	1R14-039
3001	1S3-013	6946	2B9-254	7782	2B14-470	8050	1R14-039
4001	1S3-011	6947	2B9-255	7788	2B9-245	8052	1R14-042
7001	1S4-007	6948	2B9-251	7790	2B12-324	8053	1R14-147
7002	1S4-007	7009	1B12-301	7795	2B10-226	8091	1R14-171
7003	1S4-035	7043	1B12-305	7798	3B14-356	8197	1R12-562
7007	1S4-067	7103	1B14-350	7800	3B14-360	8204	1R12-508
7010	1S4-008	7105	1B14-351	7808	3B14-354	8527	1R12-603
7014	1S5-120	7112	1B14-358	7816	3B14-359	8708	1R13-177
7017	1S5-006	7119	2B9-240	7818	3B14-359	8709	1R13-159
7017	1S5-120	7123	2B14-367	7843	3B14-457	8710	1R13-124
7031	1S4-007	7124	2B12-340	7846	3B14-451	8713	1R13-176
7035	1S45-121	7133	2B14-367	7847	3B14-459	8729	1R13-130
7040	1S4-056	7135	2B14-360	7850	3B14-452	8748	1R13-152
7042	1S5-120	7136	2B14-356	7862	3B14-464	8749	1R13-153
7044	1S5-120	7140	2B14-359	7990	3B12-329	8751	1R13-159
7050	1S4-035	7145	2B14-354	7994	3B12-328	8752	1R13-138
7055	1S4-035	7146	2B14-355	7995	3B12-329	8754	1R13-053
7056	1S45-113	7180	2B12-425	7996	3B12-335	8755	1R13-124
7080	1S45-107	7181	2B12-411	8006	3B12-304	8778	1R14-130
7081	1S5-038	7183	2B12-412	8008	3B12-300	8782	1R13-109
7086	1S4-058	7184	2B12-429	8010	3B12-301	8792	1R14-045
7087	1S5-040	7185	2B12-318	8018	3B12-303	8802	1R12-434
7108	1S5-057	7325	2B8-550	8025	3B12-300	8805	1R12-438
7110	1S5-152	7344	2B12-304	8027	3B12-310	8806	1R12-445
W023587036	1S5-186	7400	2B12-309	8030	3B12-301	8829	1R12-615
FIRESTONE		7401	2B12-320	8032	3B12-319	8852	1R12-568
Air Spring Bellows		7403	2B12-307	8033	3B12-312	8899	1R10-108
6799	2B14-476	7404	2B12-410	8038	3B12-415	8900	1R11-204
6801	2B14-365	7405	2B12-313	8039	3B12-416	8901	1R11-149
6803	2B14-366	7406	2B12-426	8042	3B12-322	8919	1R11-191
6805	2B14-462	7409	2B12-319	8043	3B12-323	8924	1R12-436
6850	2B12-463	7410	2B12-406	8047	3B12-326	8934	1R12-563
6897	2B9-229	7423	2B12-432	8048	3B12-325	8944	1R12-366
6902	2B9-239	7424	2B12-300	W013587996	3B12-335	8961	1R12-555
6905	2B9-206	7429	2B12-427	Air Spring Rolling Lobe		8964	1R12-556
6908	2B9-210	7437	2B12-320	2119	1R9-065	8976	1R12-557
6910	2B9-200	7443	2B12-305	5406	1R9-038	8986	1R12-558
6920	1B12-305	7444	2B12-416	5409	1R9-003	8997	1R9-065
6926	2B9-288	7444	2B12-446	5410	1R9-070	9010	1R12-421
6927	2B9-218	7446	2B12-402	5503	1R14-174	9015	1R12-366
6928	2B9-225	7447	2B12-324	5505	1R14-113	9017	1R10-085
6932	2B9-246	7472	2B12-434	5710	1R8-034	9017	1R10-089
6935	2B9-201	7473	2B12-428	5730	1R8-034	9018	1R12-304
6940	2B9-230	7499	2B12-317	5739	1R11-088	9026	1R12-567
6941	2B9-280	7545	2B12-345	5766	1R11-161	9029	1R12-559



EQUIVALENCIAS PARA AIR SPRINGS

No. Competidor	No. Goodyear EP
9031	1R12-350
9033	1R12-351
9039	1R12-095
9043	1R10-105
9053	1R12-309
9067	1R10-089
9069	1R12-069
9069	1R12-669
9070	1R12-370
9077	1R12-359
9078	1R12-355
9082	1R12-092
9082	1R12-509
9083	1R12-066
9092	1R12-220
9093	1R12-621
9096	1R12-155
9096	1R12-358
9098	1R12-047
9100	1R12-076
9101	1R12-103
9105	1R12-132
9113	1R12-132
9115	1R10-019
9121	1R13-039
9122	1R14-045
9127	1R12-512
9130	1R12-281
9134	1R14-137
9144	1R14-160
9148	1R14-026
9149	1R14-018
9152	1R14-019
9158	1R14-030
9164	1R14-159
9177	1R14-028
9179	1R14-028
9192	1R12-185
9194	1R12-356
9200	1R14-038
9203	1R12-395
9213	1R12-090
9215	1R14-037
9218	1R13-120
9219	1R12-182
9223	1R12-188
9227	1R12-130
FIRESTONE	

No. Competidor	No. Goodyear EP
Air Spring Rolling Lobe	
9236HR	1R10-089
9238	1R12-145
9241	1R12-261
9243	1R12-480
9245	1R12-446
9250	1R13-115
9252	1R13-116
9262	1R13-118
9264	1R14-127
9265	1R12-375
9270	1R13-119
9275	1R13-117
9287	1R12-424
9291	1R10-122
9293	1R10-120
9295	1R11-166
9296	1R12-400
9297	1R12-402
9299	1R12-366
9302	1R12-132
9303	1R12-132
9306	1R12-530
9307	1R12-435
9308	1R12-560
9320	1R12-363
9321	1R12-335
9325	1R12-505
9332	1R12-561
9334	1R12-435
9335	1R12-620
9336	1R12-648
9346	1R12-439
9348	1R12-357
9349	1R12-195
9362	1R12-441
9365	1R12-571
9366	1R12-487
9367	1R12-256
9370	1R12-580
9371	1R12-401
9373	1R12-403
9375	1R12-404
9376	1R11-200
9377	1R11-201
9378	1R11-202
9379	1R12-178
9380	1R10-091

No. Competidor	No. Goodyear EP
9386	1R10-089
9387	1R11-159
9387	1R11-203
9392	1R12-143
9415	1R11-018
9421	1R11-171
9422	1R11-028
9436	1R10-089
9439	1R11-039
9441	1R11-121
9447	1R11-066
9448	1R11-150
9457	1R11-151
9459	1R11-152
9466	1R12-365
9469	1R11-223
9470	1R12-554
9471	1R12-504
9471	1R12-552
9472	1R12-553
9473	1R12-586
9476	1R11-205
9491	1R12-553
9542	1R11-268
9547	1R11-268
9565	1R12-324
9566	1R12-204
9567	1R12-325
9568	1R12-205
9580	1R13-118
9610	1R10-089
9616	1R11-242
9617	1R11-219
9618	1R11-220
9622	1R11-221
9625	1R11-222
9634	1R12-636
9640	1R12-367
9648	1R12-538
9650	1R11-225
9675	1R11-221
9780	1R12-603
9781	1R12-603
9797	1R12-437
9921	1R12-502
9922	1R12-498
9923	1R12-481
9935	1R12-532

No. Competidor	No. Goodyear EP
9936	1R12-499
9961	1R14-115
W013588713	1R13-176
W013588753	1R13-207
W013588755	1R13-124
W013589039	1R12-095
W013589265	1R12-375
W013589270	1R13-119
W013589320	1R12-663
W013589580	1R13-118
W01-358-9616	1R11-242
W013589622	1R11-221
W013589780	1R12-303
W013589807	1R12-1047
W013589921	1R12-502
W013589974	1R12-1048
W015449542	1R11-268
FLEXIBLE	
Air Spring Bellows	
6-336-13	2B12-304
6-336-5	2B12-304
FLXIBLE	
Air Spring Rolling Lobe	
6-304-156	1R8-034
6-304-157	1R10-089
6-336-11	1R9-003
6-336-15	1R10-091
6-336-166	1R9-047
6-336-174	1R10-089
6-336-175	1R8-034
6-336-182	1R10-091
6-336-183	1R14-112
6-336-200	1R11-121
6-336-202	1R12-095
6-336-209	1R10-019
6-336-212	1R10-087
6-841-92	1R10-089
87-0808-0000	1R14-101
97-240-153	1R10-089
97-2410-0000	1R12-169
97-2410-1	1R12-169
97-2410-2	1R12-169
97-2410-3	1R12-169
97-2410-4	1R12-169
97-2410-5	1R12-169
97-5382-001	1R14-101
97-6693-1	1R12-169
97-6694-1	1R14-101

No. Competidor	No. Goodyear EP	No. Competidor	No. Goodyear EP	No. Competidor	No. Goodyear EP	No. Competidor	No. Goodyear EP
97-9999-0218	1R12-383	661756	1R10-089	2725	2B12-307	B-12405	3B12-319
T14-1035	1R14-124	661756	1R10-090	2726	2B12-309	B-12514-005	2B12-434
FLXIBLE		661759A	1R10-085	4514	3B14-360	B-12514-014	2B14-360
Air Spring Sleeve		661759C	1R10-085	4848	2B9-201	B-1345	2B12-410
97-9999-0186	1S4-007	662743	1R9-003	8221	3B12-335	B-14486	2B10-226
FRUEHAUF		662744	1R10-091	GRANNING		B-14487	3B12-312
Air Spring Bellows		667302	1R10-085	Air Spring Rolling Lobe		B-2630	2B9-201
UAB-5620	2B12-411	667512A	1R9-038	1359	1R12-066	B-2734	2B14-365
UCA-0112	2B12-412	667512C	1R9-038	1528	1R12-066	B-2883	2B12-307
UCA-0112B	2B12-412	667513A	1R10-030	1971	1R9-038	B-3184	2B14-359
UCC-3054-1	2B12-411	667513C	1R10-030	2112	1R9-070	B-3518	2B9-206
FRUEHAUF		672755	1R9-053	2727	1R12-092	B-3798	2B12-402
Air Spring Rolling Lobe		677302	1R10-085	2727	1R12-509	B-5270	2B9-206
MFR-022354	1R12-359	677302	1R10-089	5065	1R12-132	B-5468	2B12-410
MFR-022355	1R12-355	684192	1R10-089	5122	1R9-065	B-6242	2B12-324
UCB-4453-1	1R12-359	684192	1R10-090	B59	1R12-066	B-6412	2B14-366
UCB-9668-1	1R12-355	684193	1R10-089	HDA		B-6861	3B14-359
UCE-1304-1	1R12-155	684193	1R10-090	Air Spring Bellows		HENDRICKSON	
UCE-1304-1	1R12-358	684195-3	1R10-089	PMABG-6902	2B9-201	Air Spring Bellows	
UCE-1304-2	1R12-309	684242	1R10-019	PMABG-6910	2B9-200	B-7100	3B14-364
UCE-9393-1	1R12-281	698634	1R8-034	PMABG-7136	2B14-356	B-8701	2B9-255
UCE-9393-3	1R12-281	6989635	1R10-090	PMABG-7140	2B14-359	B-8768	2B9-200
UCE-9393-4	1R12-281	716110	1R10-019	PMABG-7400	2B12-309	B-8874	3B14-367
GILLIG		716111	1R9-038	PMABG-7401	2B12-320	B-9830	2B12-416
Air Spring Rolling Lobe		720414	1R10-030	PMABG-7403	2B12-307	B-9830	2B12-446
53-13187	1R11-121	8870484	1R8-034	PMABG-7424	2B12-300	C-1013	2B12-309
53-13188	1R14-018	8870485	1R10-089	PMABG-7446	2B12-402	S-12405	3B12-319
53-14006	1R11-121	8875032	1R10-085	PMABG-7798	3B14-356	S-14795	3B12-323
53-20415-000	1R14-094	8875032	1R10-089	HDA		S-7853	3B14-451
53-8212	1R11-121	G1015009	1R12-511	Air Spring Rolling Lobe		HENDRICKSON	
87-17289	1R12-505	G1017370	1R14-112	PMABG-9039	1R12-095	Air Spring Rolling Lobe	
GMC		G1019449	1R10-085	PMABG-9082	1R12-092	1R13-102	1R13-119
Air Spring Bellows		G1019450	1R10-090	PMABG-9082	1R12-509	36514-1	1R14-030
2076095	2B12-320	G1019452	1R10-087	PMABG-9105	1R12-132	36514-12	1R14-042
693230	2B12-309	G1020956	1R12-511	PMABG-9123	1R13-039	36514-13	1R14-039
711954	2B12-320	G1020957	1R10-090	PMABG-9177	1R14-028	36514-2	1R14-045
GMC		G1050310	1R14-112	HENDRICKSON		36514-3	1R12-132
Air Spring Rolling Lobe		G5008051	1R8-034	Air Spring Bellows		36514-4	1R14-030
10530086	1R8-034	GRANNING		1015	3B12-322	36514-7	1R12-092
10530087	1R10-089	Air Spring Bellows		1475	2B12-324	36514-7	1R12-509
10530087	1R10-090	1014	3B14-359	1796	2B12-345	36514-8	1R14-045
15504181	1R12-511	1015	2B14-359	36514-5	2B12-434	48195	1R12-188
2021085	1R9-038	1218	2B12-305	45843-1	2B9-206	49048	1R12-365
2052623	1R14-112	1371	2B9-200	45843-3	2B9-200	49674	1R12-365
2054879	1R14-112	1476	3B14-359	5079	2B7-548	50405	1R12-424
2090412	1R14-112	1589	2B12-305	B-1080	2B14-356	50405-1	1R12-424
2475408	1R10-019	1613	3B14-356	B-1159	2B12-307	50405-2	1R12-424
6617550	1R8-034	1626	2B14-356	B-11637	3B12-300	50898-1	1R12-402



EQUIVALENCIAS PARA AIR SPRINGS

No. Competidor	No. Goodyear EP	No. Competidor	No. Goodyear EP	No. Competidor	No. Goodyear EP	No. Competidor	No. Goodyear EP
50898-2	1R12-402	C-21623	1R13-124	Air Spring Bellows		1681741C1	1R14-024
50899-1	1R12-404	C-21800	1R13-159	1681750C1	2B12-432	1681742C1	1R14-025
50899-2	1R12-404	C-21966	1R13-177	1681751C1	2B12-434	1681743C1	1R14-027
56917-1	1R12-620	C-22045	1R13-124	1685175C1	2B9-206	1681744C1	1R14-029
56917-2	1R12-620	C-22046	1R13-124	1685176C1	2B9-218	1681745C1	1R14-031
57122-1	1R12-403	C-22173	1R13-038	1685177C1	2B12-313	1681746C1	1R14-038
B-11650	1R12-095	C-22948	1R13-176	1685178C1	2B12-319	1681747C1	1R14-042
B-12353	1R12-220	C-25873	1R14-172	1685179C1	2B12-425	1681748C1	1R14-045
B-1245	1R12-132	S-20228	1R12-563	1685180C1	2B12-426	1681749C1	1R14-060
B-12514-004	1R14-030	S-25559	1R13-119	1685181C1	2B12-427	1685174C1	1R14-039
B-12514-008	1R13-038	S-3467	1R13-038	1685182C1	2B12-428	1686386C1	1R12-401
B-12514-012	1R14-042	S-3830	1R13-038	1685183C1	2B14-365	2013947C2	1R9-054
B-14249	1R12-256	S6195	1R12-185	1685184C1	2B14-367	2013948C2	1R9-056
B-2063	1R14-030	HENDRICKSON AIR SPRING ROLLING LOBE		554782C1	1B14-358	2027911C1	1R12-538
B-2064	1R12-095	C-20217	1R12-366	554783C1	2B9-200	2027911C2	1R12-538
B-2065	1R14-028	C-20127	1R13-149	554784C1	2B9-201	2027911C3	1R12-538
B-2066	1R12-092	C-24446	1R14-236	554785C1	2B12-300	2027912C1	1R12-324
B-2066	1R12-509	C-25872	1R13-235	554786C1	2B12-305	2027913C1	1R12-325
B-22046	1R13-124	C-25872	1R13-235	554787C1	2B12-307	350243C94	1R12-432
B-2394	1R9-065	C-24445	1R14-240	554788C1	2B12-309	3541731C1	1R12-014
B-2694	1R12-395	C-25319	1R14-232	554789C1	2B12-320	3541732C1	1R12-523
B-2827	1R12-352	HISTEER		554790C1	2B12-324	3541733C1	1R11-175
B-2924	1R12-130	Air Spring Bellows		554791C1	2B12-402	3596112C1	1R12-622
B-3411	1R13-039	10301	3B14-452	554792C1	2B12-406	426212C1	1R12-014
B-3467	1R14-045	10302	2B9-252	554793C1	2B12-410	426212C1	1R12-047
B-3648	1R14-037	10302	2B9-280	554794C1	2B12-411	426212C3	1R12-014
B-3830	1R13-038	10303	3B12-303	554795C1	2B12-412	426212C3	1R12-047
B-3839	1R14-038	10303	3B12-416	554796C1	2B14-354	442305C91	1R12-047
B-3842	1R12-103	10307	2B9-266	554797C1	2B14-355	442306C91	1R12-014
B-4375	1R12-256	10313	3B12-415	554798C1	2B14-356	442306C91	1R12-047
B-4771	1R14-039	10315	2B12-346	554799C1	2B14-359	454588C91	1R12-014
B-4773	1R12-143	10316	2B14-383	554800C1	2B14-360	454588C91	1R12-047
B-5060	1R12-145	HOLLAND HITCH		554801C1	3B14-354	454590C1	1R12-014
B-7128	1R14-019	Air Spring Bellows		554802C1	3B14-356	454590C1	1R12-047
B-7193	1R11-018	4514	3B14-360	554803C1	3B14-359	501559C1	1R12-090
B-8988	1R12-195	HUTCHENS IND		554804C1	3B14-360	501559C2	1R12-090
B-9001	1R14-052	Air Spring Bellows		INT'L/NAVISTAR		517096C91	1R12-220
C-10443	1R12-208	10384-01	2B12-313	Air Spring Rolling Lobe		517559C9	1R12-092
C-13122	1R14-127	HUTCHENS IND		1660581C1	1R12-090	517559C9	1R12-509
C-20010	1R13-119	Air Spring Rolling Lobe		1660694C1	1R12-178	554761C1	1R11-018
C-20124	1R12-375	19141-01	1R11-161	1670043C1	1R12-401	554762C1	1R11-028
C-20127	1R13-118	9424-01	1R12-095	1672401C1	1R12-204	554763C1	1R12-066
C-20217	1R12-366	9424-03	1R12-095	1675495C1	1R12-205	554764C1	1R12-069
C-20223	1R12-367	9424-1	1R12-097	1681579C1	1R12-142	554764C1	1R12-669
C-20414	1R13-118	9630-01	1R12-092	1681737C1	1R12-145	554765C1	1R12-093
C-20900	1R13-159	9630-01	1R12-509	1681738C1	1R12-167	554766C1	1R12-095
C-20901	1R14-171	9630-03	1R12-093	1681739C1	1R12-182	554767C1	1R12-097
C-21208	1R13-119	INT'L/NAVISTAR		1681740C1	1R12-167		

No. Competidor	No. Goodyear EP	No. Competidor	No. Goodyear EP	No. Competidor	No. Goodyear EP	No. Competidor	No. Goodyear EP	
554768C1	1R12-103	698934	1R8-034	SC2027	2B12-402	SC2044	1R14-019	
554769C1	1R12-113	698935	1R10-090	SC2028	2B12-324	SC2045	1R14-030	
554770C1	1R12-132	G5001705	1R8-034	SC2029	3B14-356	SC2046	1R14-028	
554772C1	1R13-038	G5008052	1R10-090	SC2030	3B14-360	SC2047	1R14-037	
554773C1	1R13-039	LES AUTOBUS		SC2031	3B14-354	SC2048	1R12-090	
554774C1	1R13-048	Air Spring Sleeve		SC2032	3B14-359	SC2049	1R11-018	
554775C1	1R13-049	LINK		SC2071	2B9-206	SC2050	1R11-028	
554776C1	1R14-018	AIR SPRING SLEEVE		SC2072	2B9-218	SC2052	1R14-039	
554777C1	1R14-019	1101-0061	1S6-641	SC2073	2B12-313	SC2053	1R12-113	
554778C1	1R14-026	G5006637	1S3-011	SC2074	2B12-319	SC2054	1R12-093	
554779C1	1R14-028	LINK CAB & SEAT SPRINGS		SC2075	2B12-425	SC2055	1R13-049	
554780C1	1R14-030	Air Spring Sleeve		SC2076	2B12-426	SC2056	1R13-048	
554781C1	1R14-037	1101-0001	1S3-011	SC2077	2B12-427	SC2057	1R12-047	
INT'L/NAVISTAR		1101-0020	1S4-007	SC2078	2B12-428	SC2058	1R12-097	
Air Spring Sleeve		1101-0021	1S4-008	SC2079	2B14-365	SC2070	1R12-182	
1680378C1	1S4-016	1101-0023	1S4-044	SC2080	2B14-367	SC2098	1R14-045	
2012771C1	1S5-072	1101-0024	1S4-056	SC2101	2B12-432	SC2099	1R14-060	
INT'L/NAVISTAR		1101-0025	1S4-175	SC2119	3B12-301	SC2108	1R12-142	
2591909C1	1S6-641	1101-0030	1S45-073	SC2122	2B9-250	SC2109	1R12-145	
KENWORTH		1101-0031	1S45-179	SC2123	2B9-251	SC2110	1R12-178	
Air Spring Rolling Lobe		1101-0040	1S5-005	SC2124	2B9-252	SC2111	1R14-025	
K-102-A	1R11-018	1101-0041	1S5-006	SC2125	2B9-253	SC2112	1R14-024	
K-303-14	1R11-028	1101-0042	1S5-032	SC2126	2B9-254	SC2113	1R14-027	
K-303-15	1R11-028	1101-0043	1S5-038	SC2127	2B9-255	SC2114	1R14-029	
K-303-16	1R11-242	1101-0044	1S5-135	SC2128	2B12-434	SC2115	1R14-031	
K-303-18	1R11-219	1101-0045	1S5-133	SC2129	2B14-366	SC2116	1R14-038	
K-303-19	1R11-220	1101-0060	1S6-046	SC2130	3B12-300	SC2120	1R12-256	
K-303-22	1R11-221	1101-A042	1S5-032	SC2131	3B12-303	SC2121	1R14-042	
K-303-25	1R11-222	1102-0022	1S4-123	SC2132	3B12-304	SC2776	1R13-070	
K-303-28	1R11-221	1102-0043	1S45-113	SC2784	3B12-312	LOADAIR		
K-303-5	1R11-018	LOAD GUARD		LOAD GUARD		Air Spring Bellows		
K-303-6	1R11-028	Air Spring Bellows		Air Spring Rolling Lobe		P10-754U	2B6-535	
KWIK-LOK/TODCO		SC2010	2B9-201	SC2033		1R12-095	MACK TRUCK	
Air Spring Bellows		SC2011	2B9-200	SC2034		1R12-069	Air Spring Bellows	
53671	2B14-367	SC2012	1B14-358				227QS32	2B8-550
CP-5223	2B12-427	SC2013	2B14-360				57QK1113	2B8-550
KWIK-LOK/TODCO		SC2014	2B14-356	LOAD GUARD			57QL239	2B14-354
Air Spring Rolling Lobe		SC2015	2B14-359	Air Spring Rolling Lobe			MACK TRUCK	
CP-3281	1R12-092	SC2016	2B14-354	SC2034	1R12-669	Air Spring Rolling Lobe		
CP-3281	1R12-509	SC2017	2B14-355	SC2035	1R12-092	364SQ27	1R12-404	
CP-5125	1R12-092	SC2018	2B12-411	SC2035	1R12-509	364SQ28	1R12-365	
CP-5125	1R12-509	SC2019	2B12-412	SC2036	1R12-066	57QL332	1R13-070	
CP-5152	1R12-092	SC2020	2B12-309	SC2037	1R12-014	57QL39306	1R13-070	
CP-5152	1R12-509	SC2022	2B12-410	SC2038	1R12-103	57QL411M	1R12-365	
LES AUTOBUS		SC2023	2B12-406	SC2039	1R12-132	57QL414M	1R12-404	
10530086	1R8-034	SC2024	2B12-300	SC2040	1R13-039	MACK TRUCK		
10530087	1R10-090	SC2025	2B12-320	SC2041	1R13-038	Air Spring Sleeve		
661759C	1R10-085	SC2026	2B12-305	SC2042	1R14-026	227QS310BM	1S6-026	
				SC2043	1R14-018			



EQUIVALENCIAS PARA AIR SPRINGS

No. Competidor	No. Goodyear EP
227QS312AM	1S6-025
227QS312BM	1S5-154
227QS33	1S4-007
227QS34B	1S4-067
227QS38B	1S5-055
227QS39301	1S4-008
227QS45M	1S5-146
227QS46M	1S6-025
MASA	
Air Spring Bellows	
227002002	2B12-309
227004001	2B9-201
227138412	2B9-200
MCI	
38832	C90
8L27154	C93
8L2798	C93
MCI	
Air Spring Bellows	
12C-1-36	2B9-240
12C-3-52	2B12-340
MCI	
Air Spring Rolling Lobe	
12-01-1002	1R14-141
12-01-1048	1R14-141
12-03-1029	1R14-106
12-03-1041	1R11-115
12F-4-34	1R10-091
12G-1-60	1R12-304
12J-1-23	1R12-139
12J-1-88	1R12-154
12J-3-53	1R11-047
12K-1-45	1R12-288
12K-3-11	1R12-156
12L-1-104	1R12-217
12L-1-126	1R12-288
12L-1-133	1R12-304
12L-1-135	1R12-304
12L-1-136	1R12-217
12L-1-140	1R12-396
12L-1-142	1R12-304
12L-1-169	1R12-394
12L-1-215	1R12-454
12L-4-212	1R9-053
12L-4-261	1R10-091
12L-4-5	1R10-091
12L-4-8	1R9-053
12M-4-6	1R10-091

No. Competidor	No. Goodyear EP
14002	1R11-200
1496372	1R10-099
1498928	1R11-189
1510979	1R13-133
1512076	1R11-143
2992101C1	1R12-403
39390246	1R10-101
MERITOR	
Air Spring Rolling Lobe	
202796	1R13-130
MILSCO	
Air Spring Sleeve	
07067A	1S5-057
MONOCO COACH	
Air Spring Rolling Lobe	
14002	1R11-200
NEW FLYER	
Air Spring Rolling Lobe	
13	1R13-053
14635	1R12-285
55089	1R11-178
5920815	1R9-003
5973877	1R9-003
5973923	1R9-003
5993113	1R9-003
65	1R12-285
9594	1R12-512
99865	1R11-179
NEWAY	
Air Spring Bellows	
570-07-180	2B12-425
905-57-001	2B14-360
905-57-002	1B12-301
905-57-014	2B12-300
905-57-015	2B12-320
905-57-016	2B12-309
905-57-026	1B14-358
905-57-028	1B14-358
905-57-039	2B14-355
905-57-041	1B14-358
905-57-203	2B14-476
905-57-236	3B12-322
905-57-237	2B9-250
905-57-257	2B14-469
AR-1520	2B14-355
AR-1834	1B14-358
TC-144-2	2B12-300
TC-144-3A	2B12-320

No. Competidor	No. Goodyear EP
TC-144-4	2B12-309
NEWAY	
Air Spring Rolling Lobe	
900-44-197	1R14-031
900-44-199	1R12-097
900-44-200	1R12-093
900-44-201	1R12-113
900-44-216	1R12-093
900-44-647	1R12-093
900-44-653	1R12-113
900-44-658	1R13-048
900-44-668	1R13-048
900-44-670	1R13-049
900-44-701	1R12-103
900-44-702	1R13-049
900-44-708	1R12-097
900-54-218	1R12-113
900-54-234	1R12-097
900-57-001	1R14-029
905-44-608	1R13-070
905-54-060	1R13-049
905-57-003	1R14-028
905-57-005	1R14-030
905-57-006	1R12-092
905-57-006	1R12-509
905-57-007	1R12-621
905-57-008	1R12-103
905-57-009	1R12-103
905-57-011	1R12-095
905-57-012	1R12-351
905-57-019	1R13-039
905-57-020	1R13-038
905-57-023	1R12-095
905-57-027	1R12-092
905-57-027	1R12-509
905-57-029	1R9-065
905-57-031	1R12-220
905-57-032	1R12-621
905-57-034	1R9-065
905-57-035	1R12-621
905-57-037	1R12-092
905-57-037	1R12-509
905-57-038-1	1R12-370
905-57-052	1R13-039
905-57-054	1R12-092
905-57-054	1R12-509
905-57-069	1R14-030
905-57-070	1R13-070

No. Competidor	No. Goodyear EP
905-57-071	1R13-038
905-57-075	1R12-092
905-57-075	1R12-509
905-57-076	1R13-038
905-57-077	1R13-038
905-57-078	1R13-039
905-57-082	1R12-103
905-57-083	1R13-039
905-57-085	1R12-095
905-57-087	1R13-070
905-57-089	1R12-560
905-57-090	1R12-370
905-57-097	1R11-225
905-57-098	1R14-147
905-57-099	1R12-363
905-57-102	1R14-170
905-57-103	1R14-113
905-57-110	1R13-047
905-57-111	1R14-159
905-57-112	1R12-480
905-57-113	1R12-441
905-57-117	1R12-502
905-57-118	1R12-481
905-57-119	1R12-498
905-57-120	1R10-120
905-57-121	1R11-166
905-57-122	1R10-122
905-57-125	1R14-137
905-57-126	1R12-439
905-57-129	1R12-435
905-57-139	1R10-122
905-57-149	1R12-505
905-57-152	1R12-586
905-57-155	1R14-160
905-57-156	1R12-499
905-57-157	1R12-532
905-57-159	1R12-571
905-57-160	1R12-487
905-57-167	1R13-152
905-57-168	1R13-153
905-57-170	1R12-434
905-57-173	1R12-508
905-57-179	1R12-586
905-57-185	1R13-038
905-57-200	1R14-174
905-57-209	1R13-120
905-57-210	1R12-487
905-57-211	1R12-554

No. Competidor	No. Goodyear EP	No. Competidor	No. Goodyear EP	No. Competidor	No. Goodyear EP	No. Competidor	No. Goodyear EP
905-57-212	1R12-552	Air Spring Bellows		63-0090	1R11-090	Air Spring Bellows	
905-57-213	1R12-553	0550-00001	2B12-425	63-0092	1R11-088	12906-01	2B9-218
905-57-214	1R12-485	0550-00015	1B14-350	63-0093	1R11-243	12906-02	2B9-218
905-57-215	1R12-484	0550-00030	3B14-354	63-0094	1R11-090	18813-01	2B12-440
905-57-216	1R12-486	PEERLESS		63-0099	1R11-243	19983-01	2B14-383
905-57-223	1R12-508	Air Spring Rolling Lobe		63-0102	1R11-244	20018-01	2B12-440
905-57-225	1R12-487	0550-00010	1R14-018	63-0104	1R11-088	REYCO	
905-57-230	1R12-562	0550-00051	1R12-350	63-0105	1R11-243	Air Spring Rolling Lobe	
905-57-275	1R12-543	0550-00060	1R14-024	63-0106	1R11-090	12882-01	1R12-092
AR-1115-1-F	1R14-028	0550-00070	1R14-026	63-0125	1R12-631	12882-01	1R12-509
AR-1115-1-G	1R13-039	0550-00080	1R14-019	63-0126	1R11-244	12882-02	1R13-039
AR-1215-1-F	1R14-030	0550-00081	1R14-019	63-0129	1R11-097	12883-01	1R12-103
AR-1215-1-G	1R13-038	PETERBILT		63-0158	1R10-087	12883-02	1R13-038
AR-1315-1-F	1R12-092	Air Spring Rolling Lobe		63-0178	1R12-145	12884-01	1R12-188
AR-1315-1-G	1R12-092	03-01649	1R12-069	63-0179	1R12-156	12884-01A	1R12-188
AR-1515-1	1R12-351	03-01649	1R12-669	63-0180	1R12-288	12928-01	1R12-421
AR-250-12	1R13-153	03-02038	1R12-069	63-0181	1R12-217	17360-01	1R12-560
AR-250-14	1R13-152	03-02038	1R12-669	63-0182	1R12-304	17361-01	1R11-204
AR-250-15	1R13-152	03-02456	1R12-069	63-0183	1R12-396	17636-01	1R12-195
AR-250-16	1R13-153	03-02456	1R12-669	63-0224	1R12-394	20074-01	1R12-561
AR-250-17	1R13-153	03-04759	1R12-069	63-0226	1R8-034	20446-01	1R11-205
AR-90112	1R12-370	03-04759	1R12-669	63-0259	1R11-244	21054-01	1R11-201
NOVABUS		03-05107	1R12-356	63-0260	1R11-243	21055-01	1R12-557
Air Spring Rolling Lobe		03-06213	1R12-567	PREVOST		21598-01	1R12-556
G1015009	1R12-511	03-07111	1R12-567	Air Spring Sleeve		23377-01	1R12-555
G1076863	1R10-105	03-07112	1R12-069	95-0208	1S3-011	23631-01	1R14-039
G1202328	1R11-169	03-07112	1R12-669	R & S TRUCK & BODY		RIDEWELL	
G1202651	1R11-169	03-07887	1R12-568	Air Spring Bellows		Air Spring Bellows	
G1202652	1R11-169	23-10042	1R12-069	1027405	2B9-200	1002B09270G	2B9-270
G1202944	1R12-511	PETERBILT		1027505	2B9-201	1003586801C	2B14-365
G5001705	1R8-034	Air Spring Rolling Lobe		1027519	2B12-309	1003586805C	2B14-462
N15558	1R10-089	23-10042	1R12-669	1027556	2B14-356	1003586850C	2B12-463
N16374	1R11-121	PEZZANI		1040201	2B12-307	1003586902C	2B9-239
N16375	1R8-036	Air Spring Bellows		1082914	2B12-402	1003586905C	2B9-206
N17842	1R11-130	AR-21-A	2B14-360	1090201	2B12-307	1003586910C	2B9-200
N21126	1R8-036	PREVOST		1090214	2B14-359	1003586932C	2B9-246
N21361	1R12-422	Air Spring Bellows		1090215	2B12-300	1003586945C	2B9-253
NOVABUS		63-0166	2B9-240	R & S TRUCK & BODY		1003586946C	2B9-254
Air Spring Sleeve		63-0173	2B9-200	Air Spring Rolling Lobe		1003586947C	2B9-255
N12687	1S3-011	63-0174	2B9-216	1090023	1R13-039	1003586948C	2B9-251
ORION		63-0185	2B12-340	1090216	1R14-028	1003587112C	1B14-358
Air Spring Rolling Lobe		PREVOST		1090217	1R12-092	1003587135C	2B14-360
010132404-4	1R12-383	Air Spring Rolling Lobe		1090217	1R12-509	1003587136C	2B14-356
020117511-4	1R10-109	63-0040	1R12-127	1090218	1R12-095	1003587140C	2B14-359
20117526	1R10-127	63-0044	1R10-089	1090276	1R12-132	1003587145C	2B14-354
20217501	1R11-147	63-0045	1R12-028	1090326	1R14-159	1003587146C	2B14-355
T14-1044	1R10-109	63-0067	1R10-087	10907	1R12-261	1003587180C	2B12-425
PEERLESS		63-0077	1R10-108	REYCO		1003587400C	2B12-309



EQUIVALENCIAS PARA AIR SPRINGS

No. Competidor	No. Goodyear EP
1003587406C	2B12-426
1003587437C	2B12-320
1003587443C	2B12-305
1003587473C	2B12-428
1003587800C	3B14-360
1003587808C	3B14-354
1003587818C	3B14-359
1003587839C	3B14-359
1003588008C	3B12-300
1003588010C	3B12-301
1003588030C	3B12-301
1006587437C	2B12-320
S-1326-C	2B14-360
S-1505-C	3B14-360
S-1728-C	2B9-201
S-2683-C	2B12-305
S-2685-C	3B14-359
S-2845-C	2B9-206
S-3159-C	2B12-426
S-3363-C	2B12-320
S-3364-C	1B14-358
S-4302-C	2B12-307
S-4512-C	2B9-200
S-4538-C	2B12-425
S-4540-C	2B14-354
S-4830-C	3B14-354
S-5844-C	3B12-301
S-788-C	2B12-309
RIDEWELL	
Air Spring Rolling Lobe	
1000001	1R12-467
1000002	1R14-127
1000008	1R14-175
1001R12584G	1R12-584
1001R13-087	1R13-097
1001R13-097	1R13-097
1001R13-109	1R13-109
1003580725C	1R12-132
1003585410C	1R9-070
1003588752C	1R13-097
1003588802C	1R12-434
1003588802X	1R12-445
1003588805C	1R12-438
1003588919C	1R11-191
1003588924C	1R12-436
1003588986C	1R12-558
1003588997C	1R9-065
1003589010C	1R12-421

No. Competidor	No. Goodyear EP
1003589029C	1R12-559
1003589039C	1R12-095
1003589053C	1R12-309
1003589073C	1R11-018
1003589082C	1R12-092
1003589082C	1R12-509
1003589083C	1R12-066
1003589101C	1R12-103
1003589105C	1R12-132
1003589121C	1R13-039
1003589122C	1R13-038
1003589158C	1R14-030
1003589177C	1R14-028
1003589200C	1R14-038
1003589218C	1R13-120
1003589245C	1R12-446
1003589250C	1R13-115
1003589252C	1R13-116
1003589275C	1R13-117
1003589334C	1R12-435
1003589378C	1R11-202
1003589387C	1R11-203
1003589447C	1R11-066
1003589448C	1R11-150
1003589457C	1R11-151
1003589459C	1R11-152
1003589797C	1R12-437
1003589961C	1R14-115
1013580702C	1R12-097
1013580708C	1R11-018
1013580712C	1R12-093
1013589039C	1R12-095
1013589102C	1R12-113
1013589123C	1R13-049
1013589124C	1R13-048
1013589154C	1R14-031
1013589159C	1R14-029
S-2061-C	1R12-095
S-2572-C	1R14-038
S-2573-C	1R14-028
S-2574-C	1R14-030
S-3052-C	1R13-039
S-3053-C	1R13-038
S-4695-C	1R14-028
S-4797-C	1R14-028
S-5356-C	1R12-095
S-542-C	1R12-092
S-542-C	1R12-509

No. Competidor	No. Goodyear EP
S-570-C	1R12-132
S-5828-C	1R12-103
S-740-C	1R12-103
SAUR AXLES	
Air Spring Bellows	
P10-755	2B12-300
P50-733A	2B9-201
PB10-784	2B12-434
SAUR AXLES	
Air Spring Rolling Lobe	
P50-705	1R12-132
P50-733B	1R13-039
P50-734	1R12-095
SEARS SEAT	
Air Spring Sleeve	
S-20235	1S45-121
S-9383	1S45-121
SILENT DRIVE	
Air Spring Bellows	
AS-7446	2B12-402
AS-8025	3B12-310
AS-8027	3B12-310
SMOOTH RIDE	
Air Spring Bellows	
P10-755C	2B12-304
SUSPENSIONS INC	
Air Spring Bellows	
200042	2B9-201
200117	3B12-310
200118	2B9-252
200177	3B14-452
200180	2B9-254
200448	2B12-307
200620	3B12-304
200835	2B9-250
200981	2B12-313
201602	2B12-317
SUSPENSIONS INC	
Air Spring Rolling Lobe	
200041	1R12-142
200457	1R12-095
200458	1R14-038
201335	1R12-256
201869	1R12-092
201869	1R12-509
202796	1R13-130
TAURUS	
Air Spring Bellows	

No. Competidor	No. Goodyear EP
AS214-7180	2B12-425
AS214-7181	2B12-411
AS214-7183	2B12-412
AS214-7400	2B12-309
AS214-7401	2B12-320
AS214-7403	2B12-307
AS214-7404	2B12-410
AS214-7405	2B12-313
AS214-7406	2B12-426
AS214-7409	2B12-319
AS214-7410	2B12-406
AS214-7424	2B12-300
AS214-7429	2B12-427
AS214-7437	2B12-320
AS218-6902	2B9-201
AS218-6905	2B9-206
AS218-6910	2B9-200
AS218-6927	2B9-218
TAURUS	
Air Spring Rolling Lobe	
AS103-9073	1R11-018
AS302-9302	1R12-132
AS500-0702	1R12-097
AS500-9031	1R12-350
AS500-9033	1R12-351
AS500-9039	1R12-095
AS500-9077	1R12-359
AS502-0725	1R12-132
AS502-9053	1R12-309
AS502-9105	1R12-132
AS502-9113	1R12-132
AS504-9069	1R12-069
AS504-9069	1R12-669
AS504-9070	1R12-370
AS504-9096	1R12-358
AS506-0712	1R12-093
AS506-9069	1R12-069
AS506-9069	1R12-669
AS506-9080	1R12-066
AS506-9082	1R12-092
AS506-9082	1R12-509
AS506-9093	1R12-103
AS506-9194	1R12-356
AS509-9101	1R12-103
AS509-9102	1R12-113
AS509-9203	1R12-395
AS509-9238	1R12-145
AS509-9241	1R12-261

No. Competidor	No. Goodyear EP	No. Competidor	No. Goodyear EP	No. Competidor	No. Goodyear EP	No. Competidor	No. Goodyear EP
AS509-9348	1R12-357	4327	2B12-300	4455	3B14-364	8325	1R12-155
AS621-9121	1R13-039	4329	3B14-356	4456	3B14-451	8325	1R12-358
AS621-9123	1R13-049	4331	2B12-406	4457	3B14-367	8327	1R12-309
AS621-9148	1R14-026	4333	3B14-360	4463	2B9-254	8328	1R12-351
AS621-9149	1R14-018	4334	2B12-320	4464	2B12-434	8329	1R12-355
AS621-9159	1R14-029	4336	3B14-354	4465	2B12-432	8330	1R12-370
AS621-9177	1R14-028	4337	2B12-320	4466	3B12-310	8331	1R12-359
AS621-9179	1R14-028	4339	1B14-358	4468	1B12-301	8332	1R12-621
AS621-9181	1R14-024	4340	2B12-324	4469	3B12-300	8333	1R12-066
AS621-9198	1R14-027	4342	2B14-355	4471	2B12-412	8337	1R11-039
AS621-9961	1R14-115	4343	2B12-427	4472	2B12-411	8339	1R12-350
AS622-9122	1R13-038	4345	2B14-367	4480	2B12-440	8345	1R12-421
AS622-9124	1R13-048	4346	2B12-410	4499	2B9-201	8352	1R12-356
AS622-9154	1R14-031	4362	2B9-210	4502	2B12-317	8353	1R12-130
AS622-9156	1R14-019	4363	2B12-425	4503	3B12-304	8355	1R12-395
AS622-9158	1R14-030	4364	2B12-313	4505	2B9-229	8356	1R12-145
TMC		4365	2B12-426	4508	3B12-312	8358	1R12-261
Air Spring Rolling Lobe		4367	2B12-319	4509	2B8-550	8360	1R12-363
10530087	1R10-090	4368	2B12-432	4510	2B9-245	8361	1R12-261
661759C	1R10-085	4369	2B12-416	4513	2B12-324	8363	1R13-116
684192	1R10-090	4369	2B12-446	4514	2B12-345	8364	1R14-026
684193	1R10-090	4370	2B12-402	4520	3B12-335	8365	1R14-018
6989635	1R10-090	4371	2B12-434	4524	2B10-226	8366	1R14-028
G1020957	1R10-090	4372	2B12-428	4525	3B12-312	8367	1R14-115
TOYO		4374	2B14-354	4530	2B14-383	8370	1R14-019
Air Spring Rolling Lobe		4413	3B12-319	4541	2B12-346	8372	1R12-220
TRL230H3603	1R11-028	4426	2B9-250	4544	2B14-470	8374	1R12-047
TRL-240/393	1R12-092	4427	2B9-253	4546	3B12-328	8376	1R12-143
TRL-240/393	1R12-509	4428	2B9-255	4547	3B12-329	8377	1R13-047
TRL-250	1R12-103	4429	2B9-251	TRIANGLE		8378	1R14-042
TRL-270/476	1R13-038	4430	3B12-304	Air Spring Rolling Lobe		8379	1R12-178
CROSS REFERENCE INFORMATION TRAILERS DE MONTERREY		4431	3B12-300	8310	1R12-092	8380	1R14-147
Air Spring Bellows		4432	3B12-301	8310	1R12-509	8382	1R12-303
73312A	2B12-424	4434	3B12-303	8311	1R12-095	8382	1R12-603
73312B	2B9-216	4436	3B14-356	8312	1R12-069	8390	1R12-446
TRIANGLE		4437	3B14-359	8312	1R12-669	8391	1R12-441
Air Spring Bellows		4439	3B14-360	8313	1R14-045	8393	1R12-567
4310	2B9-201	4441	3B14-452	8314	1R11-028	8395	1R12-505
4311	2B14-360	4442	1B14-350	8315	1R12-103	8397	1R12-561
4313	2B12-309	4447	1B14-351	8316	1R14-028	8398	1R12-560
4315	2B9-206	4448	2B9-252	8317	1R13-039	8399	1R12-559
4316	2B14-359	4448	2B9-280	8318	1R14-030	8400	1R12-558
4318	2B12-307	4449	2B14-366	8319	1R12-132	8401	1R11-204
4320	2B9-200	4450	2B9-230	8320	1R14-039	8405	1R14-159
4321	2B14-356	4451	2B14-365	8321	1R12-281	8406	1R12-424
4323	2B12-305	4452	2B9-246	8322	1R11-018	8407	1R12-090
4325	3B14-359	4453	2B9-218	8323	1R13-117	8408	1R12-182
		4454	2B9-266	8324	1R13-115	8409	1R12-188



EQUIVALENCIAS PARA AIR SPRINGS

No. Competidor	No. Goodyear EP
8410	1R12-365
8414	1R14-037
8415	1R14-038
8416	1R12-400
8417	1R11-166
8422	1R13-120
8424	1R10-120
8425	1R10-122
8427	1R12-367
8428	1R12-498
8429	1R12-481
8431	1R14-137
8433	1R13-119
8434	1R13-118
8435	1R12-375
8436	1R12-366
8438	1R12-195
8443	1R12-502
8444	1R13-070
8446	1R9-070
8447	1R11-202
8449	1R12-615
8450	1R12-205
8451	1R12-404
8454	1R12-499
8456	1R12-538
8460	1R13-159
8461	1R12-325
8462	1R12-438
8465	1R12-620
8467	1R12-553
8468	1R11-171
8469	1R12-434
8470	1R12-439
8471	1R12-435
8472	1R12-568
8477	1R11-200
8478	1R11-201
8479	1R11-203
8480	1R12-556
8482	1R12-435
8484	1R12-508
8486	1R13-153
8488	1R12-487
8490	1R12-370
8495	1R12-571
8496	1R12-437
8497	1R12-436

No. Competidor	No. Goodyear EP
8501	1R12-554
8503	1R12-557
8505	1R12-256
8513	1R13-130
8514	1R11-219
8515	1R11-242
8516	1R11-205
8517	1R11-191
8518	1R13-097
8519	1R12-403
8520	1R12-402
8521	1R12-401
8522	1R13-124
8523	1R14-160
8525	1R9-065
8526	1R13-177
8530	1R14-174
8533	1R13-176
8537	1R11-221
8538	1R11-222
8539	1R14-127
8542	1R12-555
8544	1R12-563
8548	1R12-532
8563	1R11-150
TRUCKSTELL	
Air Spring Bellows	
63640	3B14-354
63641	2B14-360
63644	2B14-360
TRUCKSTELL	
Air Spring Rolling Lobe	
63647	1R12-103
TTX	
Air Spring Bellows	
1999408	2B9-225
WATSON & CHALIN	
Air Spring Bellows	
AS-0001	2B9-200
AS-0002	2B9-239
AS-0003	2B12-309
AS-0004	2B14-356
AS-0005	2B12-402
AS-0006	3B14-356
AS-0007	2B12-307
AS-0008	2B14-359
AS-0009	2B12-300
AS-0014	2B12-320

No. Competidor	No. Goodyear EP
AS-0019	3B12-300
AS-0019-1F	3B12-328
AS-0020	2B9-206
AS-0021	2B14-365
AS-0025	3B14-359
AS-0027	2B12-305
AS-0030	2B8-550
AS-0032	2B14-470
AS-0033	3B14-359
AS-0034	2B14-476
AS-0035	2B9-210
AS-0041	2B9-250
AS-0048	3B12-319
AS-0048-1F	3B12-329
AS-0048-2G	3B12-324
AS-0048-3G	3B12-342
AS-0058	2B9-229
AS-0075	3B12-303
AS-0086	3B14-452
AS-0087	2B12-346
AS-0087-1F	2B12-345
AS-0088	2B9-245
AS-0089	2B14-383
WATSON & CHALIN	
Air Spring Rolling	
AS-0010	1R14-028
AS-0011	1R12-092
AS-0012	1R12-095
AS-0013	1R13-039
AS-0015	1R12-132
AS-0017	1R11-028
AS-0018	1R12-066
AS-0023	1R13-038
AS-0023-1G	1R14-154
AS-0026	1R9-065
AS-0028	1R12-066
AS-0029	1R9-070
AS-0036	1R12-335
AS-0039	1R14-039
AS-0040	1R12-103
AS-0044	1R12-421
AS-0047	1R14-174
AS-0047G	1R14-170
AS-0049	1R12-441
AS-0050	1R12-370
AS-0053	1R12-370
AS-0054	1R12-487
AS-0056	1R12-439

No. Competidor	No. Goodyear EP
AS-0057	1R12-580
AS-0061	1R12-480
AS-0073	1R13-120
AS-0077	1R12-069
AS-0077	1R12-669
AS-0078	1R14-042
AS-0082	1R14-038
AS-0083	1R13-039
AS-0084	1R13-119
AS-0090	1R12-502
AS-0095	1R12-309
AS-0096	1R13-115
AS0098	1R13-207
AS-0101	1R12-356
AS-0104	1R12-256
AS-0107G	1R13-155
AS-0113G	1R12-541
AS-0144	1R14-190

No. Competidor	No. Goodyear EP
BLUEBIRD	
Air Spring Rolling Lobe	
6 6.5B-11 S 525	1R9-065
6 6.5B-11 S 525	1R9-065
FLXIBLE	
Air Spring Rolling Lobe	
6 6.5-13 S 039	1R9-003
9 9-14 A 337	1R11-121
9 10-10 P 311	1R12-095
FLXIBLE	
Air Spring Sleeve	
SC29-0001	1S4-007
FLXIBLE	
Air Spring Bellows	
FD 330-22 500	2B12-304
FD 330-22 500	2B12-304
FREIGHTLINER	
Air Spring Rolling Lobe	
9 10S-16 A 382	1R12-603
WC1-358-3900	1R12-303
WC1-358-3901	1R12-303
W01-358-9780	1R12-303
WC1-358-3900	1R12-603
WC1-358-3901	1R12-603
8527	1R12-603
FREIGHTLINER	
Air Spring Sleeve	
SC31-Y215	1S5-175
FREIGHTLINER	
Air Spring Bellows	
W01-358-7400	2B12-309
W01-358-7410	2B12-406
GILLIG	
Air Spring Rolling Lobe	
	1R14-094
GRANNING	
Air Spring Bellows	
W01-358-7443	2B12-305
HENDRICKSON TRUCK	
Air Spring Rolling Lobe	
	1R12-188

No. Competidor	No. Goodyear EP
W01-358-9466	1R12-365
W01-358-9466	1R12-365
W01-358-9287	1R12-424
W01-358-9297	1R12-402
W01-358-9375	1R12-404
W01-358-9335	1R12-620
W01-358-9466	1R12-365
W01-358-9466	1R12-365
W01-358-9287	1R12-424
W01-358-9297	1R12-402
W01-358-9375	1R12-404
W01-358-9335	1R12-620
	1R12-403
HENDRICKSON TRUCK	
Air Spring Bellows	
FD 110-17A 775	2B7-548
FD 110-17A 775	2B7-548
HENDRICKSON AUXILIARY	
Air Spring Rolling Lobe	
9 10-21 A 505	1R12-256
HENDRICKSON AUXILIARY	
Air Spring Bellows	
FD 330-22 346	2B12-410
HENDRICKSON CANADA	
Air Spring Rolling Lobe	
W01-358-9158	1R14-030
W01-358-8052	1R14-042
W01-358-9092	1R12-220
W01-358-9082	1R12-092, 1R12-509
W01-358-9228	1R13-039
W01-358-9122	1R13-038
HENDRICKSON CANADA	
Air Spring Bellows	
W01-358-7135	2B14-360
W01-358-7472	2B12-434
HENDRICKSON TRAILER	
Air Spring Rolling Lobe	
W01-358-8755	1R13-124
W01-358-9105	1R12-132
W01-358-9264	1R14-127
W01-358-9367	1R12-256



No. Competidor	No. Goodyear EP
W01-358-9270	1R13-119
W01-358-9265	1R12-375
W01-358-9580	1R13-118
W01-358-9015	1R12-366
W01-358-8944	1R12-366
W01-358-9640	1R12-367
W01-358-8934	1R12-563
W01-358-9581	1R13-118
W01-358-9158	1R14-030
W01-358-9039	1R12-095
W01-358-9177	1R14-028
W01-358-8751	1R13-159
W01-358-8091	1R14-171
W01-358-9579	1R13-239
W01-358-8709	1R13-159
W01-358-8708	1R13-177
W01-358-8755	1R13-124
W01-358-8710	1R13-124
W01-358-8756	1R13-124
W01-358-5511	1R13-038
W01-358-8713	1R13-176
W01-358-2119	1R9-065
W01-358-8774	1R14-172
W01-358-9203	1R12-395
W01-358-9010	1R12-352
W01-358-9227	1R12-130
W01-358-9122	1R13-038, 1R14-045
W01-358-9215	1R14-037
W01-358-9122	1R13-038
W01-358-9200	1R14-038
W01-358-9240	1R12-103
W01-358-8050	1R14-039
W01-358-9392	1R12-143
W01-358-9238	1R12-145
W01-358-9156	1R14-019
W01-358-9073	1R11-018
W01-358-9349	1R12-195
9 10-13.5 S 433	1R13-239
11 10.5-21 A 313	1R14-045
11 10.5-21 A 313	1R14-045

HENDRICKSON TRAILER

Air Spring Bellows

No. Competidor	No. Goodyear EP
W01-358-7400	2B12-309
W01-358-7136	2B14-356
W01-358-7403	2B12-307
W01-358-8008	3B12-300
W01-358-8032	3B12-319
W01-358-7795	2B10-226
W01-358-8033	3B12-312
W01-358-8043	3B12-323
W01-358-6902	2B9-201
W01-358-6801	2B14-365
W01-358-7403	2B12-307
W01-358-7140	2B14-359
W01-358-6905	2B9-206
W01-358-7446	2B12-402
W01-358-6905	2B9-206
W01-358-7404	2B12-410
W01-358-7447	2B12-324
W01-358-6803	2B14-366
W01-358-7839	3B14-359
W01-358-7843	3B14-364
W01-358-7846	3B14-451
W01-358-6947	2B9-255
W01-358-6910	2B9-200
W01-358-7847	3B14-367
W01-358-7444	2B12-416, 2B12-446

MACK

Air Spring Rolling Lobe

W01-358-9043	1R10-105
--------------	----------

NAVISTAR

Air Spring Rolling Lobe

W01-358-9287	1R12-424
W01-358-9371	1R12-401
W01-358-9371	1R12-401
W01-358-9472	1R12-553
W01-358-9098	1R12-047

NAVISTAR

Air Spring Sleeve

W02-358-7081	1S5-038
W02-358-7081	1S5-038

NEWLITE (NS 190-16)

Air Spring Rolling Lobe

W01-358-8204	1R12-508
--------------	----------

No. Competidor	No. Goodyear EP
PETERBILT	
Air Spring Rolling Lobe	
W01-358-9069	1R12-669
Air Spring Sleeve	
29-03200	1S5-186
PORCUPINE	
Air Spring Rolling Lobe	
9 9-12 P 401	1R11-088
PORCUPINE	
Air Spring Bellows	
FD 200-19 320	2B9-200
R & S TRUCK & BODY	
Air Spring Rolling Lobe	
W01-358-9121	1R13-039
SAF HOLLAND (NEWAY)	
Air Spring Rolling Lobe	
W01-358-9158	1R14-031
9 10-10 P 311	1R12-097
9 10-16 P 310	1R12-093
W01-358-9101	1R12-113
9 10-16 P 310	1R12-093
90557306	1R12-1047
90557332	1R12-1048
W01-358-9177	1R14-028
W01-358-9158	1R14-030
W01-358-9082	1R12-092, 1R12-509
W01-358-9093	1R12-621
W01-358-9101	1R12-103
W01-358-9101	1R12-103
9 10-10 P 311	1R12-095
W01-358-9033	1R12-351
W01-358-9121	1R13-039
W01-358-9122	1R13-038
W01-358-9039	1R12-095
9 10-16 P 310	1R12-092
W01-358-9082	1R12-509
W01-358-8997	1R9-065
W01-358-9092	1R12-220
W01-358-9093	1R12-621
W01-358-8997	1R9-065
W01-358-9093	1R12-621

No. Competidor	No. Goodyear EP
W01-358-9082	1R12-092, 1R12-509
W01-358-9070	1R12-370
FS 530-14 339	1B14-358
9 10-19 P 315	1R13-039
W01-358-9121	1R12-092, 1R12-509
W01-358-9158	1R14-030
W01-358-9122	1R13-038
W01-358-9082	1R12-092, 1R12-509
W01-358-9122	1R13-038
W01-358-9122	1R13-038
W01-358-9121	1R13-039
W01-358-9101	1R12-103
W01-358-9121	1R13-039
W01-358-9039	1R12-095
W01-358-9308	1R12-560
W01-358-9070	1R12-370
W01-358-9650	1R11-225
W01-358-8053	1R14-147
W01-358-9320	1R12-363
W01-358-5511	1R14-170
W01-358-5505	1R14-113
W01-358-9121	1R13-047
W01-358-9138	1R14-159
W01-358-9243	1R12-480
W01-358-9362	1R12-441
W01-358-9921	1R12-502
W01-358-9923	1R12-481
W01-358-9922	1R12-498
W01-358-9293	1R10-120
W01-358-9295	1R11-166
9 9K-15 P 425	1R10-122
W01-358-9134	1R14-137
W01-358-9346	1R12-439
W01-358-9307	1R12-435
W01-358-9291	1R10-122
W01-358-9325	1R12-505
W01-358-9473	1R12-586
W01-358-9144	1R14-160
W01-358-9936	1R12-499
W01-358-9935	1R12-532
W01-358-9365	1R12-571
W01-358-9366	1R12-487



No. Competidor	No. Goodyear EP
W01-358-8748	1R13-152
W01-358-8749	1R13-153
W01-358-8802	1R12-434
W01-358-8204	1R12-508
W01-358-9473	1R12-586
W01-358-9122	1R13-038
W01-358-5503	1R14-174
W01-358-9218	1R13-120
W01-358-8203, W01-358-9366	1R12-487
W01-358-9470	1R12-554
W01-358-9471	1R12-552
9 10-17.5 P 573	1R12-553
W01-358-9471	1R12-485
W01-358-9473	1R12-484
W01-358-9504	1R12-486
W01-358-8204	1R12-508
W01-358-9366	1R12-487
W01-358-8197	1R12-562

SAF HOLLAND (NEWAY)

Air Spring Bellows

FD 330-22 363	2B12-425
W01-358-9039, W01-358-7135	2B14-360
W01-358-7009	1B12-301
W01-358-7424	2B12-300
W01-358-7437	2B12-320
W01-358-7400	2B12-309
FS 530-14 339	1B14-358
W01-358-7112	1B14-358
W01-358-7146	2B14-355
W01-358-6799	2B14-476
W01-358-8042	3B12-322
W01-358-6943	2B9-250

SAF HOLLAND HITCH

Air Spring Bellows

W01-358-7800	3B14-360
--------------	----------

SAUER

Air Spring Rolling Lobe

W01-358-9039	1R12-095
--------------	----------

SAUER

Air Spring Bellows

W01-358-7424	2B12-300
--------------	----------

No. Competidor	No. Goodyear EP
W01-358-7423	2B12-434
	2B9-201

SILENT DRIVE

Air Spring Bellows

W01-358-8027	3B12-310
--------------	----------

SUSPENSION INC.

Air Spring Rolling Lobe

W01-358-9394	1R12-142
--------------	----------

VOLVO

Air Spring Rolling Lobe

9 10-16 P 449	1R12-615
W01-358-8829	1R12-615
W01-358-9296	1R12-400
9 10-16 P 449	1R12-615
9 10-16 P 449	1R12-615
9 10-16 P 449	1R12-615
W01-358-9296	1R12-400
9 10-14 P 312	1R12-069, 1R12-669
W01-358-9270	1R13-119
W01-358-9422	1R11-028
W01-358-9101	1R12-103
W01-358-9781	1R12-603
W01-358-9039	1R12-095
W01-358-9265	1R12-375
9 10-16 P 407	1R12-090
W01-358-9466	1R12-365
W01-358-9321	1R12-335
W01-358-9321	1R12-335
W01-358-9122, 8792	1R14-045
W01-358-9219	1R12-182
9 10-16 P 408	1R12-182
W01-358-9219	1R12-182
W01-358-9219	1R12-182
W01-358-9219	1R12-182

VOLVO

Air Spring Bellows

W01-358-7401	2B12-320
W01-358-6905	2B9-206
W01-358-7410	2B12-406
W01-358-7145	2B14-354
FD 530-22 374	2B14-354

Firestone Flex Member

Firestone Membrana Núm: □	Firestone Núm:	Goodyear Air Spring Núm:	Firestone Membrana Núm: □	Firestone Núm:	Goodyear Air Spring Núm
113B-1	7112	1B14-358	1T15M-0	9077	1R12-359
1T15S-6	9043	1R10-089	1T15M-11	9320	1R12-363
1T15LP-5	9293	1R10-120	1T15MT-6	9466	1R12-365
1T15LP-5	9291	1R10-122	1T15ML -7	8944	1R12-366
1T15S-6	9073	1R11-018	1T15MT-3	9640	1R12-367
1T15L-1.5	9422	1R11-028	1T15M-4	9070	1R12-370
1T15L-2	9447	1R11-066	1T15M -10	9265	1R12-375
1T15L-2	9448	1R11-150	1T15M-9	9203	1R12-395
1T15L-2	9457	1R11-151	1T15M-6	9296	1R12-400
1T15L-2	9459	1R11-152	1T15MT-8	9371	1R12-401
1T15TM-1	5766	1R11-161	1T15MT-8	9297	1R12-402
1T15LP-5	9295	1R11-166	1T15MT-8	9373	1R12-403
1T15TM-1	9421	1R11-171	1T15MT-8	9375	1R12-404
1T15L-4	8919	1R11-191	1T15M-4	8802	1R12-434
1T15L-2	9376	1R11-200	1T15M-6	8924	1R12-436
1T15L-2	9377	1R11-201	1T15M-4	9797	1R12-437
1T15L-2	9378	1R11-202	1T15M-4	8805	1R12-438
1T15L-2	9387	1R11-203	1T15M-9	9346	1R12-439
1T15L-2	8900	1R11-204	1T15M-6	9362	1R12-441
1T15L-2	9476	1R11-205	1T15M-4	8806	1R12-445
1T15LA-1	9617	1R11-219	1T15M-9	9245	1R12-446
1T15LA-0	9618	1R11-220	1T15M-9	9243	1R12-480
1T15LA-1	9622	1R11-221	1T15M-8	9923	1R12-481
1T15LA-0	9625	1R11-222	1T15 -8	9473	1R12-484
1T15MJ-6	9098	1R12-014	1T15 -8	9471	1R12-485
1T15MJ-6	9098	1R12-047	1T15 -8	9473	1R12-486
1T15M-6	9083	1R12-066	1T15M-2	9366	1R12-487
1T15M-4	9069	1R12-069	1T15M-7.5	9921	1R12-502
1T15M-6	9213	1R12-090	1T15 -8	9471	1R12-504
1T15M-6	9082	1R12-092	1T15M-2	9325	1R12-505
1T15M-0	9039	1R12-095	1T15M-2	8204	1R12-508
1T15M-9	9101	1R12-103	1T15M-2	9078	1R12-512
1T15M-6	9227	1R12-130	1T15M-7.5	9935	1R12-532
1T15M-2	9302	1R12-132	1T15MT-8	9648	1R12-538
1T15M-9	9241	1R12-142	1T15 -8	9471	1R12-552
1T15M-6	9392	1R12-143	1T15 -8	9472	1R12-553
1T15M-9	9238	1R12-145	1T15 -8	9470	1R12-554
1T15M-6	9096	1R12-155	1T15M-0	8961	1R12-555
1T15M-9	9192	1R12-167	1T15M-0	8964	1R12-556
1T15LC-2.5	9379	1R12-178	1T15M-0	8976	1R12-557
1T15M-6	9219	1R12-182	1T15M-0	8986	1R12-558
1T15M-6	9223	1R12-188	1T15M-0	9029	1R12-559
1T15M-9	9349	1R12-195	1T15M-0	9308	1R12-560
1T15LC-2.5	9566	1R12-204	1T15M-0	9332	1R12-561
1T15LC-4.5	9568	1R12-205	1T15M-2	8197	1R12-562
1T15M-6	9193	1R12-220	1T15M-2	8934	1R12-563
1T15M-11	9321	1R12-256	1T15M-6	9026	1R12-567
1T19 -5	9204	1R12-265	1T15M-9	8852	1R12-568
1T15MT-8	9287	1R12-274	1T15M-2	9365	1R12-571
1T15M-9	9130	1R12-281	1T15M-11	9370	1R12-580
1T15 R-6	9780	1R12-303	1T19L-11	9122	1R13-038
1T15M-2	9053	1R12-309	1T19L-7	9121	1R13-039
1T15LC-2.5	9565	1R12-324	1T15 -11	9250	1R13-115
1T15LC-4.5	9567	1R12-325	1T15 -11	9252	1R13-116
1T15M-0	9031	1R12-350	1T15 -8	9275	1R13-117
1T15M-0	9033	1R12-351	1T15 L -10.5	9580	1R13-118
1T15M-4	9010	1R12-352	1T15 M-4.0	9270	1R13-119
1T15M-2	9127	1R12-355	1T19 -5	9218	1R13-120
1T15M-6	9194	1R12-356	1T17CL-5	8710	1R13-124
1T15M-9	9348	1R12-357	1T17BB-2	8729	1R13-130
1T15M-6	9096	1R12-358	1T17B-11	8748	1R13-152



EQUIVALENCIAS PARA AIR SPRINGS

Firestone By Flex Member

Firestone Membrana Núm:	Firestone Núm:	Goodyear Air Spring Núm
1T17B-11	8749	1R13-153
1T17CA-5	8709	1R13-159
1T17CA-6.5	8713	1R13-176
1T17CA-6.5	8708	1R13-177
1T19L-7	9149	1R14-018
1T19F-11	9156	1R14-019
1T19F-7	9148	1R14-026
1T19L-7	9177	1R14-028
1T19L-11	9158	1R14-030
1T19F-5	9215	1R14-037
1T19F-5	9200	1R14-038
1T19J-7	8050	1R14-039
1T19J-6	8052	1R14-042
1T19L-11	9122	1R14-045
1T19F-12	5505	1R14-113
1T19F-7	9961	1R14-115
1T19F-14	9264	1R14-127
1T19F-9	9134	1R14-137
1T19J-6	8053	1R14-147
1T19F-7	9164	1R14-159
1T19F-7	9144	1R14-160
1T19FC-6	8091	1R14-171
1T19F-12	5503	1R14-174
1T14F-4	5406	1R9-038
1T14C-1		1R9-065
1T14F-4		1R9-070
22-1.5	7443	2B12-305
22-1.5	7447	2B12-324
228-1.5	7545	2B12-345
228-1.5	7550	2B12-346
228-1.5	7446	2B12-402
22-1.5	7444	2B12-416
22-1.5	7473	2B12-428
22-1.5	7472	2B12-434
228-1.5	7555	2B12-440
22-1.5	7444	2B12-446
21-2	6801	2B14-365
21-2	6803	2B14-366
233-2	7557	2B14-383
20-2	6927	2B9-218
20-2	6943	2B9-250
20-2	6948	2B9-251
20-2	6944	2B9-252
20-2	6945	2B9-253
20-2	6946	2B9-254
20-2	6947	2B9-255
19	7009	1B12-301
20	6910	2B9-200
20	6935	2B9-201
20	6905	2B9-206
20	6908	2B9-210
20	6897	2B9-229
20	6940	2B9-230
20	6902	2B9-239
20	6932	2B9-246
20	6941	2B9-265
21	7145	2B14-354
21	7146	2B14-355
21	7136	2B14-356
21	7140	2B14-359
21	7135	2B14-360

Firestone Membrana Núm:	FirestoneG Núm:	Goodyear Air Spring Núm
21	7123	2B14-367
22	7424	2B12-300
22	7408	2B12-307
22	7400	2B12-309
22	7405	2B12-313
22	7185	2B12-318
22	7409	2B12-319
22	7401	2B12-320
22	7410	2B12-406
22	7404	2B12-410
22	7181	2B12-411
22	7183	2B12-412
22	7180	2B12-425
22	7406	2B12-426
22	7429	2B12-427
22	7423	2B12-432
26	7325	2B8-550
38	8008	3B12-300
38	8010	3B12-301
38	8018	3B12-303
38	8006	3B12-304
38	8027	3B12-310
38	8033	3B12-312
38	8032	3B12-319
38	7994	3B12-328
38	7995	3B12-329
38	7996	3B12-335
113	7103	1B14-350
113	7105	1B14-351
257	7795	2B10-226
313	7808	3B14-354
313	7838	3B14-356
313	7839	3B14-359
313	7848	3B14-360
313	7847	3B14-367
333	7846	3B14-451
333	7850	3B14-452

Información de Garantía.

Todos los Air Springs vendidos por Veyance de México, están garantizadoa como libres de defectos en manufactura y materiales; cuando estos se utilizan exclusivamente para las aplicaciones a los que hace referencia nuestro catalogo de producto. Cualquier producto que sea reclamado deberá , bajo la aprobación de Veyance de México, ser retornado a nuestro almacén de distribución con cargo al cliente por concepto de flete. Veyance de México realizará las pruebas pertinentes, y determinará en su caso la reparación o remplazo de la pieza, según sea el caso.

La responsabilidad de Veyance de México no excederá, nunca, el valor de la pieza reclamada como defectuosa.

Retorno de Producto.

Si algún Air Spring es sospechoso de tener algún defecto, debido a alguna falla en materiales y/o manufactura, contacte a su Representante de Ventas para su inspección y/o autorización para regresar la pieza a nuestras instalaciones.

AIR SPRINGS

SUPER CUSHION® AIR SPRINGS PARA TRACTOS, TRAILERS Y AUTOBUSES.

Menos vibración que la experimentada con suspensión mecánica. Su carga está mejor protegida de los impactos y de la vibración.

¿Qué más puede pedir para ayudar a sus operadores a conducir en el camino con comodidad y seguridad?





MÉXICO
01 800 439 7373

SERVICIO A CLIENTES
+52 444 834 5800

GOODYEAREP.COM.MX



DISTRIBUIDOR

CIRCUITO EXPORTACIÓN NO. 412 PARQUE INDUSTRIAL TRES NACIONES
2A ETAPA SAN LUIS POTOSÍ, S.L.P. MÉXICO CP. 78395

La marca GOODYEAR (y el pie alado) es usada por Veyance Veyance de México, S. de R.L. de C.V. bajo la licencia de The Goodyear Tire & Rubber Company. La marca Goodyear Engineered Products es fabricada y distribuida exclusivamente por Veyance Technologies, Inc. y sus afiliados. ©2012 Derechos Reservados.



BASIC PRINCIPLES OF AIR SPRINGS

GENERAL DISCUSSION

The pneumatic (air) spring is basically a column of confined gas in a container designed to utilize the pressure of the gas as a force medium of the spring. The compressibility of the gas provides the desired elasticity for suspension use.

The air spring's ability to support a mass depends upon its effective area, which is a nominal area found by dividing the load supported by the spring, by the gas pressure at any given position. The effective area is a function of the outside diameter of the flexible member and, for rolling lobe varieties, the outside diameter of the piston. Whether the effective area remains constant, increases, or decreases during deflection is governed by the design of the spring and its components. The spring rate is the result of change in effective area and the change in gas pressure as the spring is deflected. The gas pressure varies with the speed and magnitude of deflection; for a unit of deflection, the pressure and therefore, the spring rate will be different for isothermal, adiabatic, or polytropic processes.

Air springs provide an adjustable spring rate, adjustable load carrying ability, simplicity of height control, and low friction. They are adaptable for light or heavy suspension applications.

2. COMPRESSION PROCESSES

For a specific spring design, the minimum air spring rate occurs under isothermal compression conditions and the maximum spring rate occurs with adiabatic compression. The polytropic rate varies between the isothermal and the adiabatic. The isothermal rate results when all the heat of gas compression escapes so that the gas remains at a constant temperature. The isothermal rate is approached when the spring is deflected very slowly to allow time for the heat to escape. The gas temperature remains constant, and the gas pressure rise is minimal.

Adiabatic rate occurs when all the heat of compression is retained within the gas. This condition is approached during rapid spring deflection when there is insufficient time for the

heat to dissipate. The higher temperature of the gas results in a higher gas pressure and, therefore, a higher spring rate.

When the heat of compression is partially retained within the gas, a polytropic rate results. This occurs during most normal spring deflections and produces neither isothermal nor adiabatic rates, although in typical use it is much closer to the adiabatic situation.

3. LOCKED-IN SYSTEM

Air springs which are not connected to a gas source with height control or other valve arrangements are often called Locked-In systems. In a locked-in system, air springs use a fixed mass of gas as the elastic medium. A given amount of gas is sealed in the system, and remains constant for all conditions of load or deflection.

As the load on a "locked-in" air spring increases, the gas volume is reduced and the spring rate increases. Conversely, when the load on the spring is reduced, the gas expands and the increased gas volume results in a reduced spring rate. Thus, the natural vibration frequency of a suspension system using an air spring with the air locked-in generally increases as the load on the system increases.

4. ACTIVE-AIR SYSTEM

Air springs which are connected to a constant source of air through a height control or other valve arrangement are often referred to as being part of an "Active-Air" system.

The air springs maintain a relatively constant volume at a given operating height regardless of static load or gas pressure. This is the more common system in use at this time. At a given height, the load-carrying ability and the spring rate are varied by changing the pressure of the confined gas. With this type of system, an external source of compressed gas is needed to maintain the spring height as the load on the spring is changed. The natural vibration frequency of the constant volume air spring remains more uniform with changes in load than does the natural frequency of air springs in a locked-in system.

5. SPRING CHARACTERISTIC FEATURES SPECIFIC TO AN ACTIVE-AIR SYSTEM

Effective static deflection is determined by the dynamic rate at the static design position. It can be shown graphically by drawing a line tangent to the dynamic load-deflection curve at the static design position and extending it through the zero load line, then measuring the distance back to the static design position. (See Fig. 2.1.) Natural frequency is directly related to the effective static deflection.

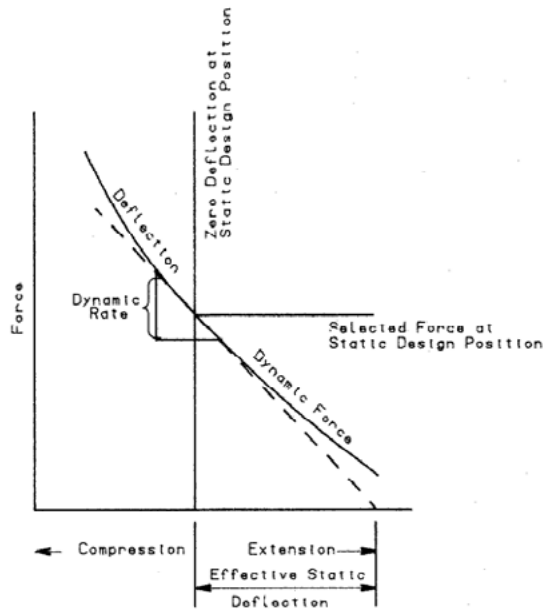

Fig. 2.1 Effective static deflection

Spring rates vary in direct proportion to the force. The natural frequency of the system stays reasonably constant throughout the normal force range.

System natural frequencies may vary by spring design, spring volume, and spring position within the system.

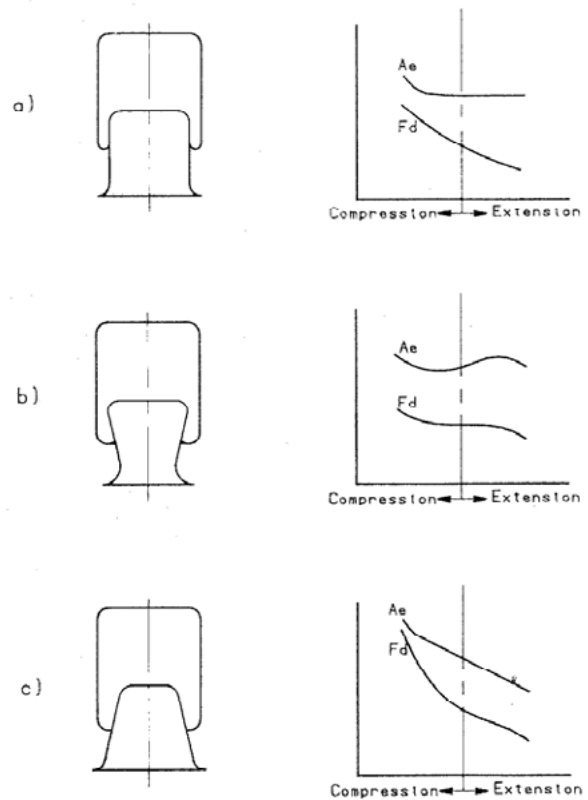

Fig. 2.2 Characteristic variations due to piston shapes and flexible member size

Figure 2.2 shows the effect of piston shape on the effective area (A_e) and on the dynamic force (F_d) curves versus spring position. The three figures (2.2a, 2.2b, and 2.2c) show the same rolling lobe flexible member with different piston types. The graphs demonstrate what effect the piston shape has on spring characteristics.

Figure 2.2a shows a straight wall piston which has a neutral effect on the effective area and spring force. The effective area curve (A_e) is essentially flat, and increases only slightly as the spring compresses. The spring force (F_d) increases as the spring is compressed due to the increase in pressure.

Figure 2.2b shows a back tapered piston which allows for the lowest spring rate. The effective area varies due to the shape of the piston. It decreases as the spring compresses, until the bottom flare of the piston takes effect, at which time, the effective area begins to increase. The force to compress also decreases over the back tapered portion of the piston, and increases again as the piston flares out which prevents rapid compression and bottoming out.

Figure 2.2c shows a positive tapered piston. This style of piston provides the highest spring rate. Both the effective area and spring force increase rapidly as the spring compresses.

6. BASIC CYLINDER AND PISTON SPRINGS

Cylinders with pistons can be used as pneumatic springs but they have several major drawbacks:

- (1) Sliding friction transmits significant forces through the spring. Short impulses are especially detrimental.
- (2) It is difficult to maintain zero gas leakage past the piston and rod seals for the desired life of the unit.
- (3) Clevises are required at the top and bottom for most mountings.
- (4) The effective area cannot be manipulated.
- (5) The piston and rod guide present wear problems.

An advantage is that high operating pressures may be used, and the unit can combine load-carrying and damping functions.

7. BASIC DESIGN CONSIDERATIONS

The flexible member structure carries only a portion of the developed spring force, with the remainder being transmitted directly through the gas column to the rigid supporting members. Stress is imposed upon the flexible member by both the internal air pressure and, in the case of the rolling lobe type air spring, by the piston contour. High initial stresses and severe fluctuations in stress result in reduced durability.

Air spring designs which have the lowest maximum stress and low stress variation with cycling will achieve the best durability. Durability is also directly coupled with imposed stress which are the result of the suspension design. Goodyear Engineered Products by Veyance Technologies, Inc. recommends that the nominal internal design pressure not exceed 100 PSIG. However, more conservative operating pressures will generally result in increased life.

To maintain their correct shape, air springs should have at least slight positive internal pressure under all deflection conditions. When flexed with no positive internal pressure, rolling lobe air springs may fold between the piston and the top mounting metals, resulting in pinching and/or rupture of the flexible member. Generally, 10 PSIG minimum pressure will prevent operation troubles. In some cases, half this pressure will suffice, but in a few special cases up to 20 PSIG may be required.

8. BASIC CALCULATION CONSIDERATIONS

The basic gas laws apply for design calculations of general characteristics in the pressure, temperature, and natural frequency ranges normally used by air springs. In addition to these factors, an effective area varying with deflection must frequently be considered. This can be accomplished by changing the size or shape of the piston.

The basic gas laws apply for design calculations of general characteristics in the pressure, temperature, and natural frequency ranges normally used by air springs. In addition to these factors, an effective area varying with deflection must frequently be considered. This can be accomplished by changing the size or shape of the piston.

It may also be necessary to take into account the fact that a nonproportional change in volume may occur during deflection.

9. GAS LAW PROCESSES

A. Definitions–Units

The mass of a vehicle and of its cargo is measured in pounds-mass (lbm) and is usually called “weight”; this mass, less the unsprung mass, acts upon the suspension springs as a load, or more accurately as a vertical downward force F (now designated ‘force of gravity’), equaling mass times acceleration of gravity and measured in pounds-force (lbf). It is generally accepted that the terms pounds-mass (lbm) and pounds-force (lbf) are interchangeable. Both are usually referred to as pounds (lb).

With an air suspension spring, the load is supported by a force which is developed as the product of gas pressure and the effective area within the air spring.

In this manual the force is measured in pounds, the gas pressure is measured in pounds per square inch (that is, the pressure above atmospheric pressure), and the effective area is measured in square inches.

$$F(\text{lb}) = P(\text{PSIG}) \times A_e (\text{in}^2)$$

The pressure of the atmosphere at sea level is in balance with a 29.9 inch column of mercury at 32°F; it equals 14.7 PSIG. The sum of the atmospheric pressure. The fundamental gas laws deal with this absolute pressure

B. Vertical Supporting Force

As shown above, the supporting force (F) is created as the product of gas gauge pressure and effective area:

$$F = P \times A_e$$

Effective area (A_e) can be found directly when the force and pressure are known. Then it is the result of dividing force by pressure.

C. Constant Pressure, No Gas Flow, Constant Effective Area

With Constant Pressure: $\frac{V_1}{T_1} = \frac{V_2}{T_2}$ or $\frac{V_1}{V_2} = \frac{T_1}{T_2}$

where: T = absolute temperature

V = total pneumatic spring and auxiliary volume

These relationships affect the air spring system when the system is at rest and only temperature changes occur. Dynamically, the only way to maintain constant pressure is in combination with infinite volume and thus is not generally useful.

D. Constant Volume, Non-Flow Process

This process (see Fig. 2.3) can be shown as:

$$\frac{P_1}{T_1} = \frac{P_2}{T_2}$$

where: P = absolute pressure

T = absolute temperature

From a practical standpoint, with true gasses this is a desirable but unattainable process because of the nature of the flexible member. Extremely large volumes may allow an approximation of the process and there are ways to obtain small ratios of volume change to total volume with feasible total volumes. (An example, interconnecting springs with only one spring undergoing a volume change at a time.)

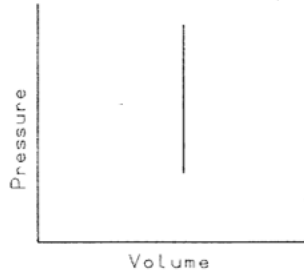

Fig. 2.3 Constant volume, non-flow process

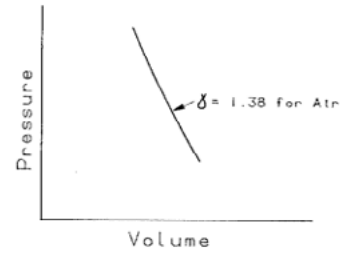

Fig. 2.5 Adiabatic non-flow process

E. Constant Temperature, Non-Flow Process (Isothermal Process)

$$P_1 \times V_1 = P_2 \times V_2$$

where: P = absolute pressure
 V = total volume
 PV = constant

This process (see Fig 2.4) must be taken into account when examining the static stability of systems. It determines the practical limit of low rate operation. Under isothermal conditions, the spring rate must be appreciably in the positive range.

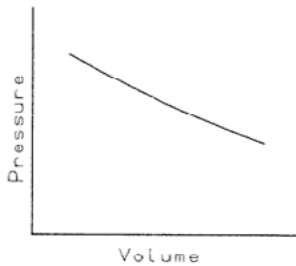

Fig. 2.4 Constant temperature non-flow process (isothermal process)

G. Polytropic, Non-Flow Process (Normal Pneumatic Spring Operation)

$$\frac{T_2}{T_1} = \frac{P_2^{(n-1)/n}}{P_1^{(n-1)/n}} = \frac{V_1^{(n-1)}}{V_2^{(n-1)}} \quad \text{OR} \quad \frac{P_2}{P_1} = \frac{V_1^n}{V_2^n}$$

where: T = absolute temperature
 P = absolute pressure
 V = total volume
 n = polytropic exponent

This is the general case where the terms pressure, volume and temperature all vary (see Fig. 2.6) Air springs operate in the full range from nearly isothermal to almost adiabatic. A generally acceptable value for n is 1.38 when the natural frequency of the system is being determined.

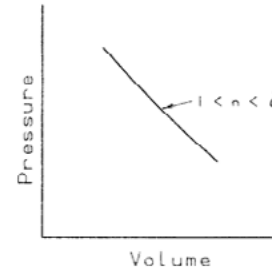

Fig. 2.6 Normal air spring operation

F. Adiabatic, Non-Flow Process: This is defined as a process with no heat transferred to or from the working fluid (see Fig. 2.5).

$$\frac{T_2}{T_1} = \frac{P_2^{(\delta-1)/\delta}}{P_1^{(\delta-1)/\delta}} = \frac{V_1^{\delta-1}}{V_2^{\delta-1}}$$

where: T = absolute temperature
 P = absolute pressure
 V = volume
 δ = adiabatic exponent

This is a theoretical process; in practice it is not attainable with air springs. However, for rapid deflections it is closely approached.

The GOODYEAR (and Winged Foot Design) trademark is used by Veyance Technologies, Inc. under license from The Goodyear Tire & Rubber Company. Goodyear Engineered Products are manufactured and sourced exclusively by Veyance Technologies, Inc. or its affiliates. The following trademarks are licensed to Veyance Technologies, Inc. by The Goodyear Tire & Rubber Company, including Compass, Eagle Pd, Flexten, Gatorback and GY Metric. ©2008 Veyance Technologies, Inc. All Rights Reserved.



AIR SPRING TYPES



1B SINGLE CONVOLUTE – BELLOWS

- * SLEEVE TYPE
- * CRIMPED

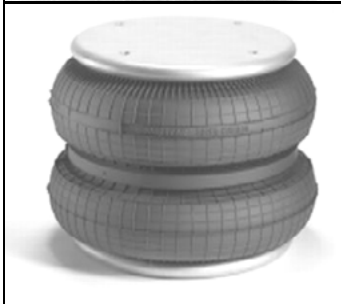

2B DOUBLE CONVOLUTE – BELLOWS

- * SLEEVE TYPE
- * CRIMPED



3B TRIPLE CONVOLUTE – BELLOWS

- * CRIMPED



1S SLEEVE TYPE ROLLING LOBE

- * SLEEVE TYPE



1R CONVENTIONAL ROLLING LOBE

- * CRIMPED

PRODUCT IDENTIFICATION SYSTEM

Elements of the part identification system are shown in the following example for ordering an assembly with the part number 2B12-300.

2 B 12-300

← The three digits that represent a unique identifier for this particular air spring

↑ The nominal outside working diameter of the air spring assembly, in inches

Refers to the type of air spring:
B – Bellows
R – Rolling lobe (bead type conventional)
S – Sleeve (beadless rolling lobe type)

↑ Number of convolutions in the assembly:

- 1 – Single convolute
- 2 – Double convolute
- 3 – Triple convolute

PRODUCT DESCRIPTION

Rolling Lobe Air Spring

Rolling lobe air springs incorporate a piston which allows the flexible member to roll along the piston's surface.

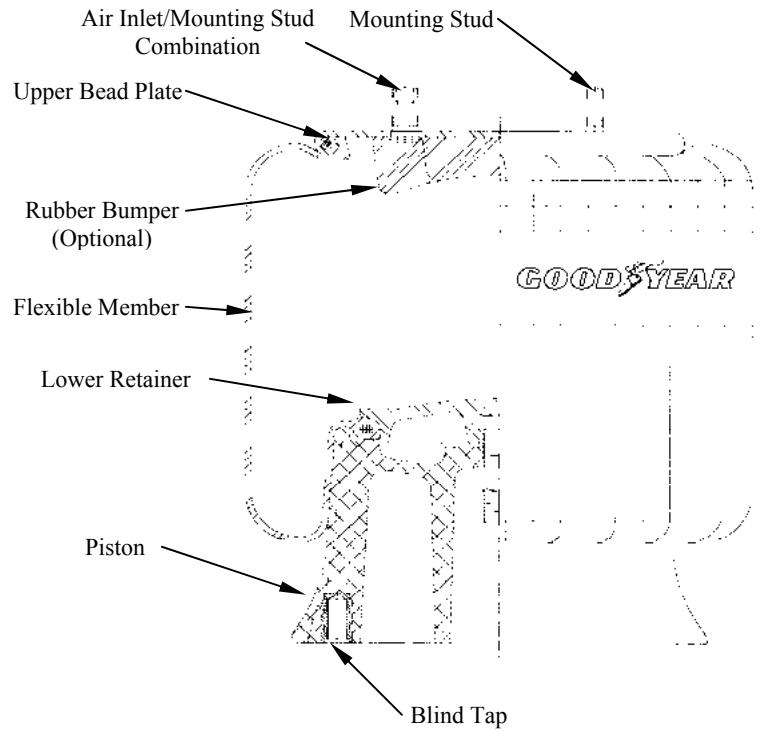

Sleeve Type Rolling Lobe

Sleeve type rolling lobe air springs employ a flexible member without an internally molded bead. The flexible member is attached to the end retainers by pinching the material between the end retainers and exterior crimp rings which are then swaged to the proper diameter.

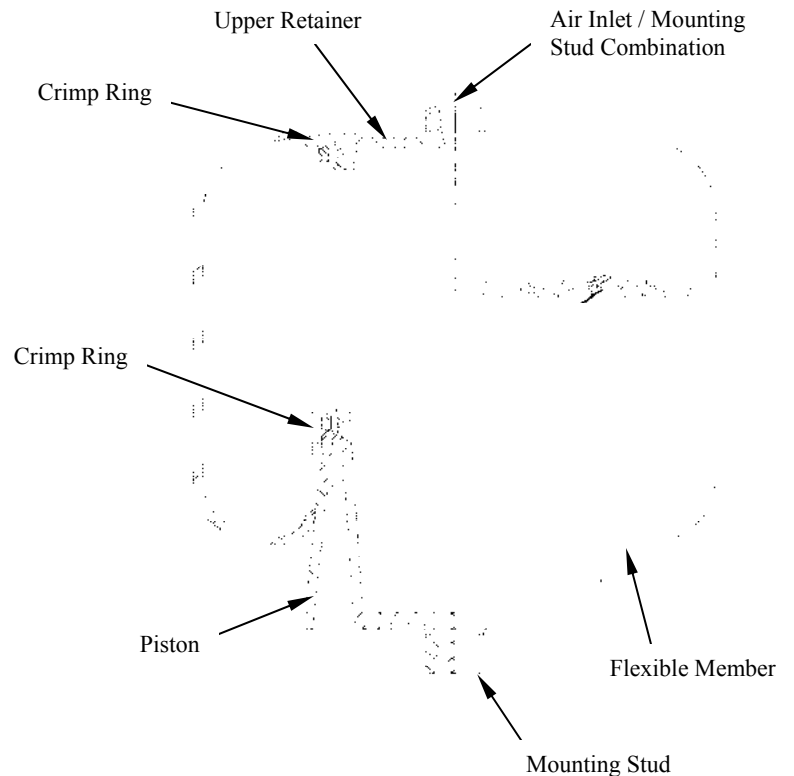

Bellows Type Air Spring

Bellows air springs have one, two or three convolutions in the flexible member. There are two styles of bellows; crimped design and sleeve type.

With the *crimped design*, the end retainers are permanently attached by mechanically crimping the retainer around the built-in bead wire of the flexible member.

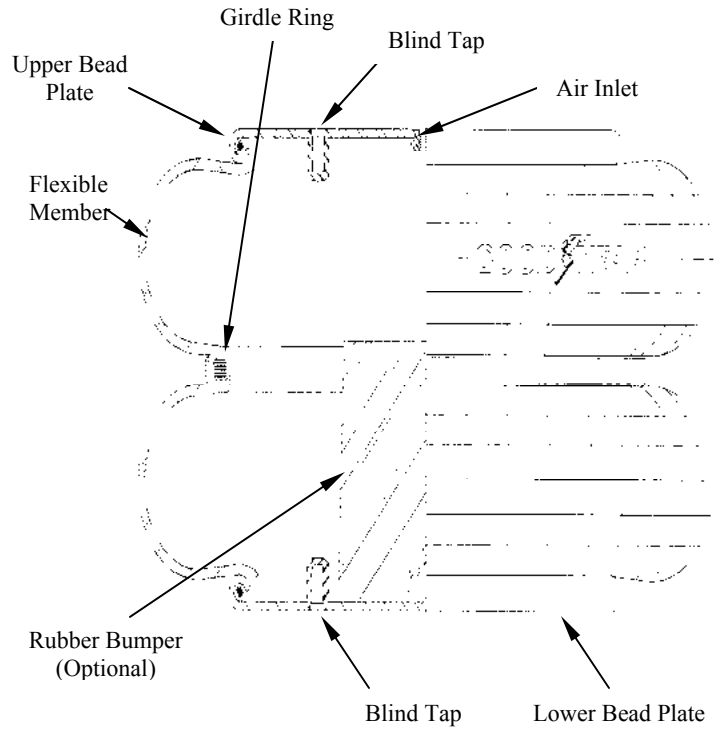

Sleeve Type Bellows

Sleeve type bellows offer similar characteristics to the crimped design bellows, but, as with the sleeve type rolling lobe the flexible member is constructed without internally molded bead wires. The end retainers are permanently attached by pinching the flexible member between the end retainers and external crimp rings which are then swaged to the proper diameter.

Sleeve type bellows offer the lowest force to compress of any type of air spring.

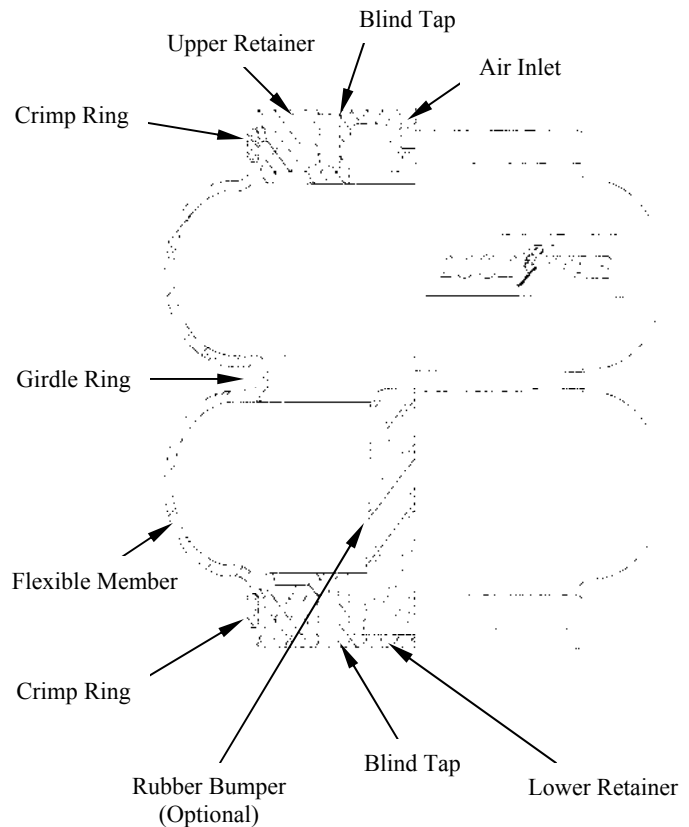

SUPER-CUSHION[®] AIR SPRING COMPONENTS

FLEX MEMBERS

Super-Cushion[®] air spring flex members are built of two plies of either nylon or polyester fabric, coated with rubber. They are designed to withstand inflation pressure, frequent flexing and misalignment. The rubber cover protects against abrasion, aging and the external environment. A rubber liner protects against the interior environment and loss of air. The elastomer used in Super-Cushion air springs can be a natural rubber compound or Wingprene[®].

The majority of vehicular Super-Cushion air springs are made of natural rubber for durability and low temperature capability. Wingprene springs are available for special applications where excessive exposure to oil may exist. Contact Veyance Technologies, Inc. for details.

RETAINERS

The purpose of the upper and lower retainers is to attach to the flexible member of the Super-Cushion air spring, thus creating an air tight seal. All retainers and pistons are made of an engineered thermoplastic or thermoset composite material; or corrosion resistant aluminum, zinc or steel.

Upper and lower retainers are made with blind taps, or protruding bolts to facilitate attachment. The upper retainer has a tap to accommodate a 1/4", 1/2" or 3/4" air fitting or valve. Although it is called the upper retainer for reference, it need not be in the up position to function properly; the attitude of the air spring does not affect its function.

BUMPERS

A rubber bumper inside the air spring assembly helps protect the flexible member and the end retainers in those applications where external compression stops are not practical. Internal bumpers are recommended when:

1. The assembly will frequently reach the "compressed height without a bumper."*
2. The assembly will occasionally reach the "compressed height without a bumper,"* but with a significant load and impact.
3. A vehicle may have to operate on a deflated air spring assembly.

*See Glossary and/or Selection Charts

END COMPONENT OPTIONS



1. CRIMPED ON RETAINERS

Available for springs:

- 1B9 and larger Bellows
- 2B9 and larger Bellows
- 3B12 and larger Bellows
- 1R8 and larger Rolling Lobes

Upper and lower retainers are attached by mechanically crimping the retainer around the bead wire built into the flexible member.



2. SWAGED ON RETAINERS

Available for springs:

- 1B5 thru 1B8 Bellows
- 2B6 thru 2B8 Bellows
- All 1S Sleeve Type Rolling Lobes

Upper and lower retainers are permanently attached by swaging a metal ring around the flexible member and end retainer.



3. BOLTED BEAD RING

In certain applications, used in place of crimped on retainers.

Available for springs:

- 1B9 and 2B9 Bellows
- 1B1 2, 2B1 2 and 3B1 2 Bellows
- 2B19 and 2B22 Bellows

Upper and lower bead rings are attached by bolting each to the customer's own mounting plate. An air tight seal is formed when all bolts are securely fastened through the bead ring into the mounting plate.

The GOODYEAR (and Winged Foot Design) trademark is used by Veyance Technologies, Inc. under license from The Goodyear Tire & Rubber Company. Goodyear Engineered Products are manufactured and sourced exclusively by Veyance Technologies, Inc. or its affiliates. The following trademarks are licensed to Veyance Technologies, Inc. by The Goodyear Tire & Rubber Company, including Compass, Eagle Pd, Flexten, Gatorback and GY Metric. ©2008 Veyance Technologies, Inc. All Rights Reserved.



COMPARISON OF AIR SPRING PERFORMANCE CHARACTERISTICS

Below is a comparison of the three basic types of Super-Cushion® air springs and desirable performance characteristics when used in identical applications.

PERFORMANCE CHARACTERISTICS	TYPE SUPER-CUSHION®
1. Highest vibration isolation percentage	Rolling Lobe (R), Sleeve (S)
2. Lowest compressed height	Bellows (B)
3. Lowest vertical spring rate – “K _v ”	Rolling Lobe (R), Sleeve (S)
4. Greatest lateral spring rate – “K _l ” (unrestrained)	Bellows (B) especially 1B sizes
5. Approximately constant force over a portion of the stroke	Rolling Lobe (R), Sleeve (S)
6. Ability to retain shape and be compressed at zero pressure	Bellows (B)

The GOODYEAR (and Winged Foot Design) trademark is used by Veyance Technologies, Inc. under license from The Goodyear Tire & Rubber Company. Goodyear Engineered Products are manufactured and sourced exclusively by Veyance Technologies, Inc. or its affiliates. The following trademarks are licensed to Veyance Technologies, Inc. by The Goodyear Tire & Rubber Company, including Compass, Eagle Pd, Flexten, Gatorback and GY Metric. ©2008 Veyance Technologies, Inc. All Rights Reserved.



Industrial Air Spring Application ◦ Actuation

Air springs have successfully solved actuating problems, at a reduced cost, in many applications including:

- Injection or ejection of parts in manufacturing processes
- Tensioning devices for cables, calendar rolls and conveyors
- Force devices for die cutting and stamping
- Positioning devices in manufacturing processes
- Clamping devices for wood gluers, etc.
- Vertical lift force for platforms and for rotation tables
- Rotary shaft actuators
- Double acting actuators for stitching machines
- Drain valve actuators
- Actuation to engage and disengage power on powered roller conveyor
- Power source in direct-acting forming press (metal and plastics)
- Power source in compactors
- Power source in laminating plywood presses
- Granite slab positioners
- Pallet lifts
- Lift actuators for diagnostic tables in hospitals
- Reciprocating shaft seal
- Underwater actuator for gate controls
- Lumber positioner actuators in sawmills
- Actuators for concrete block machinery
- Directional-change actuators in roller conveying systems
- Actuators for flask lifts on foundry shake-outs
- Actuators on bottle and carton filling machines
- Bin-tilting actuators (for ease of access)
- Actuators on transfer tables
- Actuators in sand blast rooms
- Actuators in glass grinding rooms
- Industrial laundry equipment actuators
- Energy storage device actuators
- Can forming actuators (beverage and fuel industries)
- Car/truck front end alignment rack actuators

The GOODYEAR (and Winged Foot Design) trademark is used by Veyance Technologies, Inc. under license from The Goodyear Tire & Rubber Company. Goodyear Engineered Products are manufactured and sourced exclusively by Veyance Technologies, Inc. or its affiliates. ©2008 Veyance Technologies, Inc. All Rights Reserved.



Industrial Air Spring Application ○ Vibration Isolation

Air springs have solved vibration and noise problems in multiple applications, such as:

- Vibrating shaker screens
- Vibrating conveyors
- Vibrating hoppers and bins
- Isolation of flex testing machines
- Isolation of forging hammers
- Isolation of frozen food and plastic pellet compaction systems
- Isolation of cabs on dredging machines
- Isolation of computer and spectrometers from outside vibration
- Isolation of oscillating equipment
- Isolation of sensitive equipment (laser bench) or sensitive machine controls
- Jet engine testing platforms (isolation and thrust absorption)
- Industrial suspension systems
- Large drying machines (milk dryers)
- Foundry shake-out systems
- Centrifugal separators
- Scales and weight control equipment
- Presses
- Compressors, fans and blowers
- Textile looms
- Reduction of sever impact and elimination of impact idlers at conveyor load points
- Seat suspensions
- Industrial washing machines
- Protection of Polaris and Atlas rockets in storage, ground handling transit
- Coordinate measuring tables and machinery
- Replacement of steel springs for better vibration isolation, height control or height adjustment

The GOODYEAR (and Winged Foot Design) trademark is used by Veyance Technologies, Inc. under license from The Goodyear Tire & Rubber Company. Goodyear Engineered Products are manufactured and sourced exclusively by Veyance Technologies, Inc. or its affiliates. ©2008 Veyance Technologies, Inc. All Rights Reserved.



GLOSSARY

A

Air Actuator	A device which induces action or motion with compressed air being the medium through which the power is transmitted, similar in function to a hydraulic cylinder.
Air Spring Assembly	An air spring flexible member complete with end closure components (retainers) ready to be mounted in place and used as an air actuator or vibration isolation mount.
Amplification	Act of amplifying; increase; enlargement.
Amplitude	The extent of a vibratory movement, the range of a fluctuating quantity from the average or mean position to an extreme.
Amplitude of Force Oscillation	The distance from the spring static design height to either extremity of an oscillation.
Auxiliary Volume	All volume added to the spring system beyond that included in the basic spring at the selected spring static design height as shown on the load vs. deflection at constant pressure graph for that spring.
Axle Gross Mass Rating	The axle's share of the vehicle's design rated capacity at the base of the tires.
Axle Sprung Mass	Axle gross mass less the axle unsprung mass.
Axle Travel	The distance the axle can move away from the static design position. It can be in the extension or compression direction, but must be labeled properly.
Axle Unsprung Mass	The mass of all the suspension and running gear components not supported by the pneumatic springs.

B

Bead Wire A solid or flexible wire molded into each end of a flexible member, except in a sleeve-type flexible member. It permits the end retainers to be attached to the flexible member to create an air tight seal for rolling lobe and bellows type assemblies

Bellows An air spring having one, two or three convolutions in the flexible member.

Blind Tap Attachment provision recessed in the retainer, closed at the bottom to prevent air loss. A bolt or shoulder-stud can be inserted to attach the air spring to machinery.

Bolted Bead Ring A ring used to attach certain bellows type flexible members to the mounting surface. Used in place of the conventional upper and lower crimped-on retainers.

Bumper An internal compression stop. Generally a molded rubber part attached inside the air spring assembly. It aids in preventing internal damage to the air spring assembly due to heavy loads coupled with severe compression and helps to prevent damage in the event of air loss.

C

Convolution On a bellows type air spring, that part of the flexible member forming an annular protrusion larger than the O.D. of the end retainers or the girdle ring(s).

Cover The external layer of elastomer which protects the reinforcing cords from abrasion, weathering, or other undesirable effects.

Crimped Design That type of air spring assembly in which the flexible member is permanently attached to the upper retainer by crimping the upper and lower retainers around the bead wires molded into the flexible member.

Crimp Ring A solid metal ring used to attach a sleeve or molded sleeve bellows type flexible member between the crimp ring and the end retainer.

CPM (Cycles per minute): A unit of measure of the frequency of any vibration.

D

Deflection: The amount of increase or decrease in the spring length from the spring static design height. It must be properly labeled as extension or compression.

Design Conditions: The motionless (static), position or condition, of the vehicle and all its components as stipulated in the design.

E

Effective Area: A specific area found by dividing the load supported by the air spring by its internal gas pressure at any given spring position. The effective area of the rolling lobe and sleeve type assemblies is more constant over the stroke than that of a bellows. However, all air spring generally have decreasing effective areas with extension.

Effective Diameter: A function of the effective area. The effective diameter is always less than the actual diameter of the air spring.

Effective Static Deflection: Obtained by extending a line tangent to the dynamic load deflection curve at the selected spring static design position down to the zero force line, and measuring the horizontal distance along this line separating this intersection and the vertical line defining the spring static design position.

F

Flexible Member: The rubber-fabric component in an air spring assembly consisting of special reinforcing cords sandwiched within rubber.

Forced Frequency (f_f): The number of oscillations per unit time of an external force acting on a mass. Sometimes referred to as the disturbing or exciting frequency and measured in CPM or Hertz. Also see Natural Frequency.

G

Girdle Ring: A rubber covered bundle of wires that restricts the diameter of the flexible member at the attachment point to form double or triple convolutions.

H

Height

A dimension always measured linearly along the stroke of an air spring assembly between the parallel planes of the attachment surfaces of the upper retainer and lower retainer.

a. Bumper Contact Height: That height at which the bumper contacts the opposite retainer.

b. Compressed Height: That height at which the deflection of the air spring assembly must be limited by external means to prevent possible damage to the air spring assembly. This is the shortest height shown on the load vs deflection graph and applies to any portion of the top and bottom mounting surfaces. It is not necessarily the height measured at the longitudinal center line of the spring. Also referred to as “Compressed Height without a Bumper”.

c. Design Height: The selected operational height of an air spring when mounted and inflated with the mass at rest.

d. Design Height Range: A predetermined range of heights within which the design height should be selected for optimum performance.

e. Height Limit (Actuator): The extension limit of the air spring assembly. A reduction in life is probable above this limit due to the repetition of highly concentrated stresses. Extension restraints are required.

f. Maximum Extended Height: The maximum operational height of the air spring assembly. Exceeding this height may result in structural damage to the air spring assembly. Extension restraints are required.

g. Metal to Metal Height: That height where the air spring assembly is compressed to the point where the metal or plastic retainers contact.

Height Control Valve

A device which controls the distance between a selected location on the sprung mass and the axle or other unsprung suspension component.

Hertz

Cycles per second (Hz) - a unit of measure of the frequency of any vibration.

I

Isolator (Vibration)

A device used to join one object to another, and restrict the transmission of vibration to some degree.

J

Jounce

The compression of the suspension or air spring below its design height.

L

Laterally Restrained Rolling Lobe	A rolling lobe type air spring with the flexible member contained by a rigid cylinder attached to the mounting plane opposite the piston for lateral stability.
Lever Arm	The distance from the spring centerline to the centerline of the pivot point.
Lever Arm Ratio	The spring arm distance from the attachment to the frame divided by the wheel axle arm distance from the attachment to the frame (D_s/D_w).
Liner	The internal layer of elastomer which provides resistance to gas permeability.
Load	The vertical downward force imposed by the mass.
Load Range	That range of loads which the air spring assembly can support with an inflation pressure at, or below, 100 PSIG and within the design height range.

M

Maximum Inflated Diameter (Max O.D.)	The largest diameter the air spring assembly will attain at an internal pressure of 100 PSIG or less, including a factor for growth over time.
Meniscus	That portion of the flexible member of a rolling lobe or sleeve type air spring that curves under (reverses) in the transition from working diameter to the piston diameter.
Meniscus Height (M)	The distance measured from the bottom of the meniscus to the bottom of the piston. Applies to rolling lobe and sleeve type air spring assemblies only.

N

Natural Frequency (fn) The number of cycles per unit time that a mass vibrates on its spring medium. Usually considered only in the vertical mode and expressed in Hertz (cycles per second) or CPM (cycles per minute).

Nominal Outside Working Diameter This is the one or two digit number that follows the R, S or B in the product description. It is the approximate working diameter of the Super Cushion air spring.

NPTF American National Standard Dryseal Pipe Threads. N=National (American) Standard, P=Pipe, T=Taper, F=Fuel or oil. Veyance Technologies, Inc. recommends always using a suitable thread sealant, such as Teflon tape, for additional leak protection.

O

Orifice Area The cross-sectional area of an orifice opening separating the basic spring volume from the auxiliary system volume.

P

Percent Vibration Isolation That percent of the forced frequency isolated by the air spring.

Piston A rigid structure over which the flexible member rolls. The contour of the piston affects the operating characteristics of the air spring assembly.

PSIA Pounds per square inch, absolute.

PSIG Pounds per square inch, gauge. The pressure measured by a gauge within a closed system. Zero PSIG = 14.7 PSIA at sea level.

R

Radial Clearance The minimum distance from the spring wall to nearby vehicle components. This must allow for all extreme pneumatic spring dynamic conditions.

Rebound The extension of the suspension or air spring above its design height.

Reinforcement A structure of cords built into the flexible member to control its shape and strengthen its wall structure against internal gas pressure. Normally this is two bias plies of synthetic cord.

Rolling Lobe Rolling lobe air springs incorporate a piston which allows the flexible member to roll along the piston's surface as forces change. Also referred to as a "piston-type" air spring.

Resonance The phenomenon shown by a vibrating system which responds with maximum amplitude under the action of a harmonic force. Resonance occurs when the forced frequency is the same as the natural frequency of the vibrating body.

Restraining Cylinder A rigid cylinder attached at one end to the plane of the mounted mass. When dimensionally matched to restrain the O.D. of the air spring, it also provides additional lateral support. It can eliminate the need for more elaborate stability arrangements.

Retainer The end enclosure of an air spring assembly. Two retainers are used in each air spring assembly. Generally made of metal and supplied with blind taps, protruding bolts, or a combination of these to facilitate mounting the assembly to equipment

- a. Upper Retainer:** Refers to that retainer which usually contains the air fitting. It need not be in the up position.
- b. Lower Retainer:** Refers to that retainer with no air fitting. In a bead type rolling lobe assembly, the lower retainer extends through or attaches to the piston.

S

Shoulder Stud	A threaded bolt with a shoulder that can only be driven a specified depth into a blind tap. The shoulder limits the depth and prevents fracture of the bottom of the blind tap.
Sleeve	An air spring flexible member manufactured without internal bead wires.
Sleeve Type Assembly	A rolling lobe type assembly utilizing a flexible member without internally molded bead wires.
Spring Force	The force generated by the air spring which opposes the applied force of the sprung mass.
Spring Rate (K)	The change in load per unit of deflection. a. Vertical Spring Rate (K_v): Measured along the axis of the air spring assembly. b. Lateral Spring Rate (K_l): Measured perpendicular to the axis of the air spring assembly.
Spring Rate (Wheel)	The end result of the spring rate calculations after the suspension arm ratio is applied to the spring rate.
Spring Volume	The volume inside the flexible member and connecting inside spaces in the top and bottom attached components.
Stroke (Total)	The difference between the maximum extended height and the compressed height.
Stud	A threaded bolt that can be permanently attached to the retainer or inserted into a blind tap in the retainer. Also see Shoulder Stud.
Swaged Design	That type of air spring assembly in which the flexible member is permanently attached to the end retainers with crimp rings. The flexible member is compressed between the end retainer and crimp ring by mechanically reducing the diameter of the crimp ring.

T

Tank Valve	A tire type inflation valve which can be used with an air spring assembly for manual inflation.
-------------------	---

Transmissibility	The ratio of transmitted force to exciting force.
-------------------------	---

U

UNC	Unified national coarse (thread).
------------	-----------------------------------

UNF	Unified national fine (thread).
------------	---------------------------------

W

Wheel Force	The force acting at the wheel contact point and the ground resulting from the suspended mass acting through the various suspension system components.
--------------------	---

The GOODYEAR (and Winged Foot Design) trademark is used by Veyance Technologies, Inc. under license from The Goodyear Tire & Rubber Company. Goodyear Engineered Products are manufactured and sourced exclusively by Veyance Technologies, Inc. or its affiliates. The following trademarks are licensed to Veyance Technologies, Inc. by The Goodyear Tire & Rubber Company, including Compass, Eagle Pd, Flexten, Gatorback and GY Metric. ©2008 Veyance Technologies, Inc. All Rights Reserved.



PHYSICAL APPLICATION CONSIDERATIONS

The versatility of air springs in vehicular suspensions leads the designer to new and different approaches in his designs. Tips on what is known to work best with regard to the air springs are discussed herein. Some of the conditions which are known to adversely affect the life of air springs are also presented.

The basic concept in all the desirable mounting geometries is to minimize the peak cord or bond stresses. Also, pinching and rubbing reduces air spring life and must be avoided.

1. DESIRABLE AIR SPRING MOUNTING GEOMETRIES

Suspension basic style and geometry are not considered here.

A. Rolling Lobe Air Springs

Figs. 5.1 and 5.2 show that the piston in a fully compressed position has the same centerline as the upper retainer. These figures show an ideal situation which allows ample internal clearance and full bumper contact.

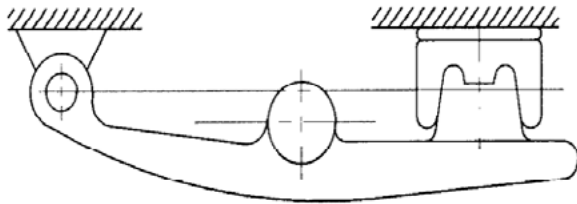

Fig. 5.1 Rolling Lobe fully compressed

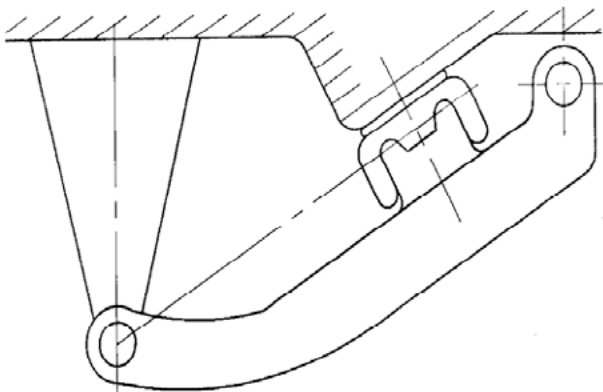

Fig. 5.2 Rolling Lobe
relationship between pivot and spring

However, Fig. 5.3 shows the range of positions in a more realistic situation. Because the air spring travels in an arcuate path, the piston and upper retainer may not have the same center line at either design height or at compressed height. Also, the maximum horizontal displacement away from the pivot arm should be less than the maximum displacement toward the pivot arm.

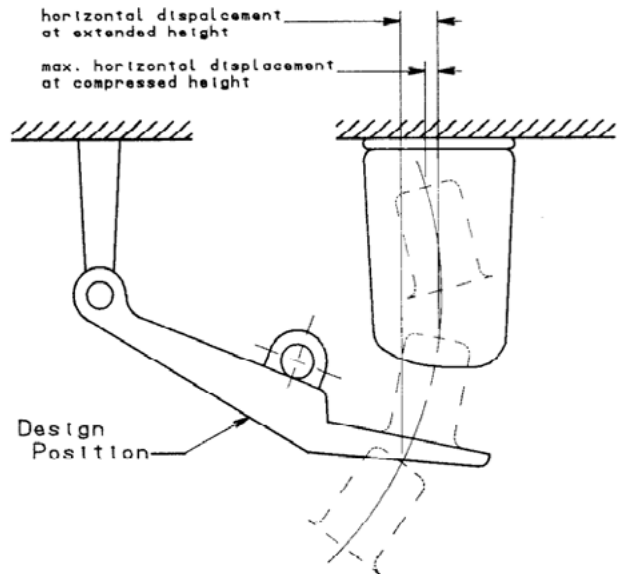

Fig. 5.3 Rolling lobe full travel

B. Bellows Type Air Springs

For maximum compression stroke, the end retainers should be parallel in the fully compressed position, as shown in Fig. 5.4. Be sure that a line drawn through the pivot point and perpendicular to the air spring assembly centerline also divides the air spring in half.

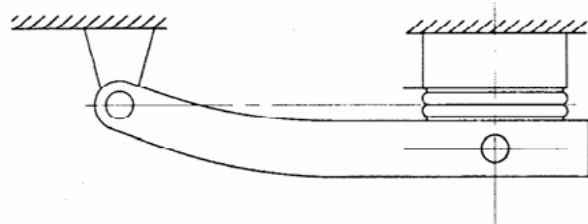

Fig. 5.4 Suspension arm with bellows air spring

The end retainers may be parallel at the design height if adequate compression stroke can be obtained. But the previous statement always applies.

The centerline of the lower retainer and the upper retainer should coincide in the fully compressed position.

C. Parallelogram Suspension Linkage

The centerline of the piston should move equal distances fore and aft of the upper retainer centerline when the piston is moved through its full travel. The normal design position is shown in Fig. 5.5.

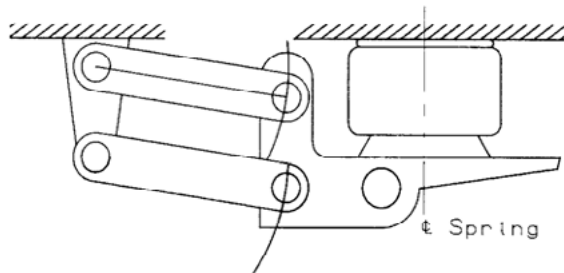
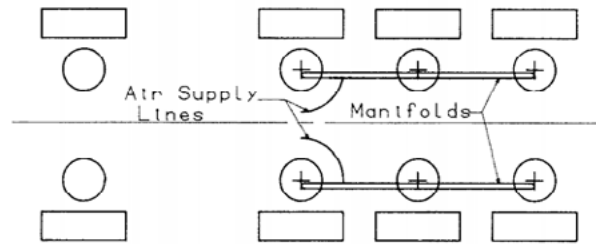

Fig. 5.5 Parallelogram suspension linkage

D. Multi-Axle Pneumatic System

With a multi-axis arrangement, it is possible to connect all the springs on each side of the vehicle or trailer to a common air supply after it has been through the height control valve (see Fig. 5.6). It is best to have the maximum size tubing practical for the application connecting all springs in such a system. The advantages are that as an individual spring flexes, all the other springs act as reservoirs, thus reducing the pressure change and the dynamic spring rate of that spring. The somewhat increased pressure in the other springs has only a mild effect on their spring rate and the shock to the vehicle is damped, reduced, and distributed over a greater area. This arrangement does not affect vehicle roll stability.



Plan View

Fig. 5.6 Multi-axle pneumatic system

2. UNDESIRABLE AIR SPRING MOUNTING GEOMETRIES

The examples mentioned in this section are extreme cases.

Pneumatic springs are capable of long operation with much abuse, but poor operating geometries will result in earlier failures than springs used with good geometries. Rather small changes in operating geometries on long stroke life tests can show 4-10 times life improvement with improved geometries. Field operations will probably not show as dramatic life improvements because of fewer long strokes in service, but certainly the trend toward improvement will be there.

Avoid centerline offset as is illustrated in Fig. 5.7. The rolling lobe type is less sensitive to misalignment than the bellows.

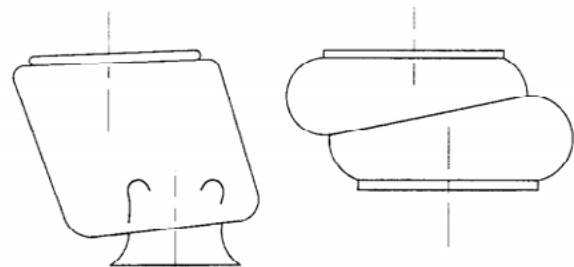

Fig. 5.7 Air springs mounted with offset centerlines (avoid if possible)

Fig. 5.8 shows piston centerlines improperly related to the pivot arm. There will be increased wear at the upper mounting plate and on the sleeve where it rolls on the piston, plus the possibility of internal rubbing.

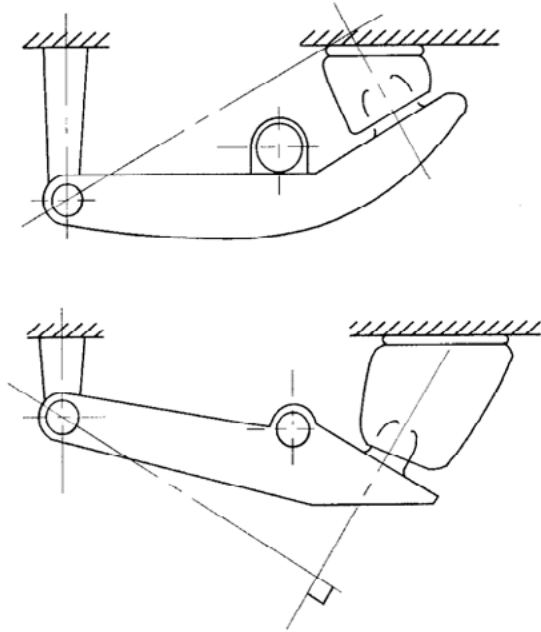

Fig. 5.8 Incorrect piston mounting angle

The lower mounting designs shown in Fig. 5.9 are unstable and unnecessary if other proper design criteria are employed.

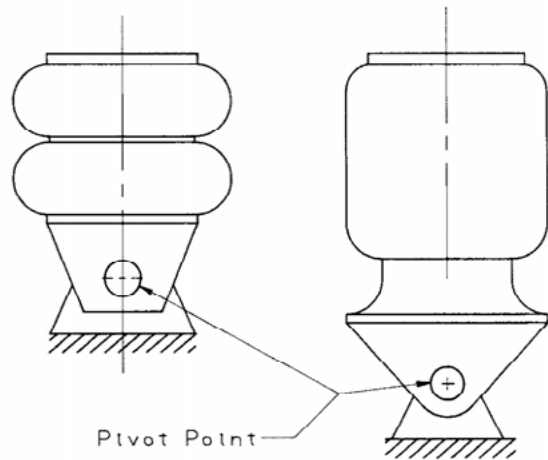

Fig. 5.9 Unstable mounting

Fig. 5.10 shows an air spring under low pressure conditions which may cause it to buckle and fold when compressed and may be damaged in the fully compressed positions. It will wear internally, causing reduced life.

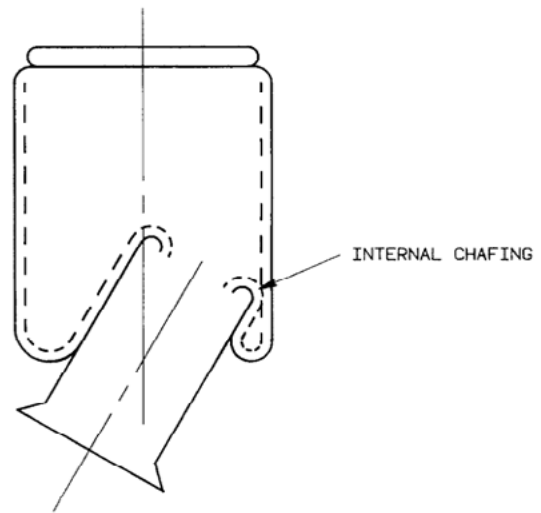

Fig. 5.10 Low pressure and internal chafing

The GOODYEAR (and Winged Foot Design) trademark is used by Veyance Technologies, Inc. under license from The Goodyear Tire & Rubber Company. Goodyear Engineered Products are manufactured and sourced exclusively by Veyance Technologies, Inc. or its affiliates. The following trademarks are licensed to Veyance Technologies, Inc. by The Goodyear Tire & Rubber Company, including Compass, Eagle Pd, Flexten, Gatorback and GY Metric. ©2008 Veyance Technologies, Inc. All Rights Reserved.



AIR SPRING APPLICATION CONSIDERATIONS FOR COMMERCIAL VEHICLES

This section is devoted to bridging the gap between the theoretical characteristic of air springs and their functional application. Recognizing that the usual application of these springs will be in conjunction with other components making up a vehicle suspension, examples are presented here in terms of the air spring design for actual suspension systems. From this presentation, the designer should be able to determine the sequence of data accumulation, analysis, and calculation required to arrive at a suitable design within his particular parameters. He should also gain an understanding of how the air spring characteristics, discussed in earlier chapters, become pertinent to overall suspension design. In addition to the design procedure examples and calculations, a section of this chapter presents generalized considerations for air spring suspension design which have evolved from the experience of suspension designers and air spring manufacturers. The advantages of pneumatic suspension are not automatically attained. The entire suspension must be properly designed if it is to take full advantage of air spring capabilities and to compensate for their few limitations.

1. REASONS FOR USING AIR SPRINGS

- A. To provide a more comfortable ride for vehicle occupants.
- B. To obtain better cargo protection through low spring rate and natural frequency
- C. To obtain longer vehicle life through less damage from road shock and vibration.
- D. To make a lighter vehicle possible, thus allowing an equivalent increase in cargo mass.
- E. To optimize load distribution on multi-axle units.
- F. To provide for auxiliary axle pick-up when the axle is not required, thus providing operating economies and improved maneuverability.
- G. To allow automatic levelling. With automatic height sensors, there is no change in vehicle height from an unloaded to a fully loaded condition. This permits the cargo space to be designed with a higher top and a lower floor without interfering with the tires while still staying within maximum vehicle height limits. Also, a constant height is maintained for use at loading docks and for trailer pick-ups.
- H. To protect the infrastructure. Low spring rate and natural frequency plus excellent load distribution protects the roads and may make pneumatically sprung vehicles acceptable on roads where units of large mass are not now allowed.

2. SUSPENSION DESIGN CONSIDERATIONS

To design a pneumatic suspension system the designer must know, in addition to what is needed for the basic design, what will be required of the air spring and what is needed to fit the spring into the total system.

The system requirements that the spring is to supply are as follows:

1. Satisfactory mechanical operation over the full axle travel.
2. Support for the sprung mass with the available air pressure.
3. The desired dynamic spring rate and system natural frequency throughout the sprung mass load range.
4. Desirable or at least satisfactory dynamic force characteristics throughout the full axle travel.

The air spring requirements that the suspension system must provide are as follows:

1. A space envelope that allows the spring to function properly at all heights.
2. An operating environment that does not seriously affect spring life.

To take maximum advantage of these possibilities, many considerations should be kept in mind. There is reserve capability and versatility built into air springs. While some violations of the following application principles can be tolerated, it is best to design to obtain as many preferred conditions as possible for long, trouble-free air spring service. Air springs can be utilized in many geometries, but in designing to get the maximum benefit in one area, care should be taken not to create an unacceptable situation in another area.

The following are significant design considerations:

- 1. Design Height**-The design height should be established within the recommended design height range since life and performance characteristics may both be adversely affected if the springs operate continuously either above or below their design range.
- 2. Operating Pressures**-For lowest spring rate and natural frequency for a particular suspension design, springs should be operated at normal pressures within 80-100 PSIG. Moderate operating pressures (40-80 PSIG) will provide maximum life. It is also necessary to maintain some positive pressure under lightest load and full rebound conditions.
- 3. Vehicle Roll Rates**-Low spring rates mean less control in vehicle roll; therefore, some auxiliary restoring force must be supplied. Levelling valves, shock absorbers, and shaped pistons may sometimes help in this situation but it is best to have a suspension design or linkage which supplies this restoring force. Some methods that have proven successful are:
 - 1) Using a roll stabilizing bar connecting one suspension arm with the other.
 - 2) Having rigid suspension arms with a rigid axis connected to the suspension arms with flexible mountings.
 - 3) Using flexible suspension arms attached rigidly to the axle.

4) Keeping the roll moment as low as possible, consistent with other design considerations.

5) Utilizing a suspension design that has as high a roll center as practical.

4. Axle Travel-Low spring rates produce more axis travel relative to the frame over irregular road sources. Thus, more axle travel is needed before cushioned stops, with their inherent high rate, come into operation. Bumpers should come into action smoothly. Rebound stops are also recommended; hydraulic shock absorbers may be used as rebound stops.

5. Damping-Air springs have considerably less hysteresis than multi-leaf steel springs. Hydraulic shock absorbers are required to control vehicle action.

6. Air Spring Placement-To increase the air spring's load carrying capacity beyond that which the spring normally provides, place the spring on a trailing arm behind the axle. However, this arrangement will work the spring harder because of repeated longer travel required to provide desired axle motion.

For extra low suspension rate and natural frequency, place the air spring between the suspension arm pivot and the axle. This will generally provide good spring life if spring operating geometry and pressure are within proper design parameters.

7. Stresses-Any operating condition that creates high stresses in the flexible member of the spring will adversely affect the spring life. Examples are springs with high design operating pressures, with long compression deflections, and springs with severe misalignment between top and bottom mounting surfaces. The significant thing to remember is not just the high stresses, but the number of times the springs are subjected to these high stresses. Rapid and repeated large changes in flexible member stresses will reduce life. Examples are springs which have portions of their structure subjected to repeated lateral motion because of excessive flexure of suspension components when cornering and springs which have small gas volume and undergo large deflections.

8. Alignment-Life may be considerably improved if the alignment between the upper and lower mounting surfaces is balanced so that the maximum misalignment is held to a minimum. The adverse effect from misalignment varies with the design and style of the spring (see "Physical Application Considerations")

9. Interference-Avoid situations where springs rub or nearly rub against anything. This also includes rubbing against themselves. Low operating pressures increase the chance that internal chafing may occur (see Fig. 6.1).

Verification of satisfactory radial clearance with other vehicle components must be made under all anticipated operating conditions. Remember that the springs will grow slightly with time and that suspensions have manufacturing tolerances. If the operating clearance of a spring appears to be a problem, keep in mind that the spring diameter is greatest at maximum pressure, which occurs when the air spring is in the fully compressed position. Considerable clearance may exist at the normal design height and even more clearance may be noted when the spring is in full rebound.

Points of possible interference must be checked experimentally; there may be more clearance than anticipated-or possibly less. If the spring is used at considerably less than the normal maximum rated pressure, there will be extra clearance. If air springs are used above their normal rated pressure, they will have larger than rated diameters.

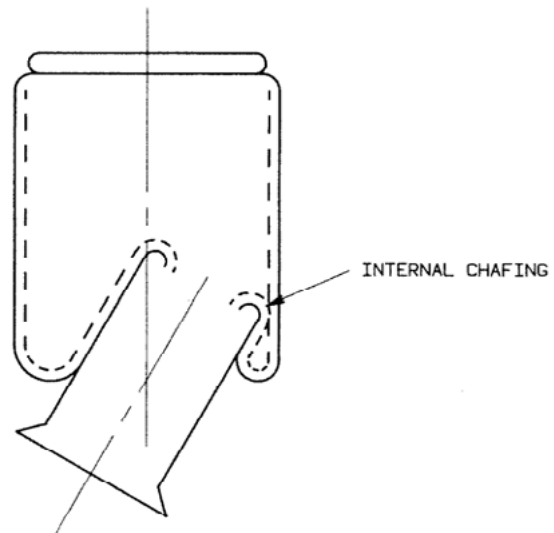

Fig. 6.1 Low pressure and internal chafing

10. Over Extension-Avoid spring extensions which appreciably flex the spring wall, even locally, close to its attachment regions. Both extension and compression stops must be used to protect against the worst condition. If this is not controlled, the spring will be damaged resulting in reduced life.

11. Internal Bumpers-Bumpers must deflect some distance before they will carry their rated load, and this should be taken into account when considering spring compression travel. In addition, internal bumpers are limited by volume considerations and are not generally designed for continuous ride use. They are meant to be used as dynamic compression bumpers and emergency ride springs only. Special shorter bumpers may be required if auxiliary axle pickup is used. Hence, they become only compression travel stops and are not auxiliary springs or true compression bumpers.

12. Road Debris-Road tar and sand, especially large particle sand, is detrimental to spring life. In cases where the spring is in line with material thrown up by the tires, a protective shield should be placed in front of the spring assembly. Users should regularly clean pistons to prevent build-up of road debris.

3. AIR SPRING SELECTION PROCEDURE

The initial step in specifying an air spring for a suspension design is to record the known and estimated system parameters. To assist in this, a Data Record Form is provided in Appendix A from which copies can be made.

As a first step, it is important to know whether or not a rubber bumper is required inside the air spring. A rubber bumper is used to support the load when the air spring is not inflated and to prevent damage to the air spring and suspension when extreme compression (jounce) contact is made. It is usually more cost effective from a suspension manufacturer's standpoint for the compression (jounce) stop to be located external to the air spring.

However, if a suspension manufacturer is supplying a suspension kit to a variety of customers where an external compression (jounce) stop might be removed or left off, then that suspension manufacturer may require an internal compression stop (rubber bumper).

DEFINITION OF VARIABLES

A_e	= Effective Area.	e	= Extension (rebound) stroke of the air spring from its design height.
Ax_c	= Maximum axle compression from design / ride height.	F	= The force required to actuate a mass; in a spring, the force that reacts the applied load.
Ax_e	= Maximum axle extension from design/ride height.	f_f	= The forced frequency that requires isolation.
C	= Compression (jounce) stroke of the air spring from its design height.	f_n	= The natural frequency of the suspension system ($f_n = f_s$ when $L_r = 1$).
D_s	= Distance from pivot to spring centerline.	f_s	= The natural frequency of the air spring (see Engineering Data).
D_w	= Distance from pivot to wheel centerline or point of applied load.	h_c	= The minimum compressed height for a particular spring application. (h_c -min=min compressed height allowable for a given air spring).
d	= Diameter of the space available at the air spring location.	h_e	= The maximum extended height for a particular spring application (h_e -max= max extended height allowable for a given air spring).
DH	= The specified design height of the air spring chosen from a range of available design heights for that spring (see Engineering Data).	K	= Spring rate; unless otherwise noted, refers to vertical spring rate +/- 10 mm about design height.
		L_d	= The design load per air spring in a multiple spring system.
		L_r	= Lever arm ratio ($L_r = D_s / D_w$).
		N	= The number of air springs in a multiple spring system.
		OD_{max}	= The maximum outside diameter of an air spring at 100 PSIG; or, the max OD possible for a particular application after allowing for clearance.
		P	= The air line pressure at the point of air spring application.
		S	= The total stroke required of the air spring ($S = c + e$).
		W	= Total weight of the sprung mass.

SELECTION PROCEDURE

Step One-

Complete the Data Record Form (Appendix A) using known or estimated values for system parameters. It is not necessary to have values for all parameters; for example, the selection of design height can be delayed until later in the procedure. Perform the suspension geometry calculations shown on the Data Record Form and record the results. See the Suspension Geometry Section for an explanation of the formulas for lever ratio (L_r), design load (L_d), and natural frequency (f_n and f_s).

Step Two-

Determine the maximum air spring diameter (OD_{max}) possible within the available space (d), allowing for clearance. A 1" clearance is recommended, so $OD_{max} = (d - 2")$. In some applications, this much clearance may not be necessary; in others, where misalignment is part of the design, additional clearance must be provided.

Step Three-

Turn to the Nominal Operating Range Selection Graph (last page). Draw a horizontal line at the required design load (L_d). Only those air spring groups that are intersected by this line can be considered further. If the height limits for the application (h_c and h_e) are known, use these values and the Assembly Height axis to further reduce the list of potential air spring groups. If h_c and h_e are not known, but required stroke (S) is known, refer to the Usable Stroke Range column in the table below the Nominal Operating Range Selection Graph. Eliminate those groups that do not meet the stroke (S) requirements.

Step Four-

Look at the "Selection Chart" that is found under Resource Center. Considering only those air spring groups selected in Step Three, use the following procedure to systematically eliminate springs that fail to meet design constraints. The sequence or the procedure itself may need to be modified depending on the information available at this point. (For example, steps 4.1 and 4.2 may be reversed if load range can be used to eliminate springs more quickly than maximum OD. In other cases, Step 4.3, bumper requirements, may be the best starting place.)

4.1. Eliminate all springs where maximum OD @ 100 PSIG is greater than OD_{max} for the application. List all remaining assembly numbers and their max ODs.

4.2. Next, eliminate all springs where L_d falls outside of the design load range. List all remaining assembly numbers and their load ranges.

4.3. If a bumper is required, use the Bumper Y/N column to eliminate those springs on the remaining list without bumpers. List all remaining assembly numbers.

4.4. If DH (or OH range) is known, use the Design Height Range column to further eliminate springs. If DH (or DH range)

is not known, proceed to step 4.5. List all remaining assembly numbers and their design height ranges.

4.5. Next, use the Usable Stroke column to eliminate all springs having usable stroke less than the required stroke (S). List all remaining assembly numbers and their stroke values.

4.6. If the assembly height limits (h_c and/or h_e) for the application are known, compare them to the minimum compressed height (h_{c-min}) and/or maximum extended height (h_{e-max}) values for each of the remaining springs. If h_c and h_e are not known, proceed to Step Five. Values for h_{e-max} will come either from the Selection Chart or from a physical constraint in the application. Eliminate all those springs where h_c is less than h_{c-min} or where h_e is greater than h_{e-max} . List all remaining assembly numbers along with their minimum compressed height and maximum extended height values. If DH is not known, proceed to Step Five. If DH is known, skip Step Five and proceed to Step Six.

Step Five-

Open "Engineering Data" and look at the Dynamic Characteristics table for each spring remaining on the list. List the three tabulated design heights for each spring. Then, referring back to the Selection Chart, list the minimum compressed height (h_{c-min}) and the maximum extended height (h_{e-max}) for each spring. Or, if the application has a maximum height constraint, use that for h_{e-max} . (Since h_{c-min} and h_{e-max} represent physical limits, each assembly number will have only one value for each.)

Now refer back to the Data Record Form, and using the calculated values for required spring compression (c) and extension (e), calculate h_c and h_e values for each of the three tabulated design heights for each spring on the current list ($h_c = DH - c$; $h_e = DH + e$). Compare the calculated h_c and h_e values to h_{c-min} and h_{e-max} for each spring/design height combination. Eliminate all those springs where h_c is less than h_{c-min} or where h_e is greater than h_{e-max} . List all remaining assembly numbers along with their h_c , h_{c-min} , h_e , and h_{e-max} values.

Step Six-

If the desired natural frequency (or desired range) of the suspension system (f_n) is known, the desired natural frequency (or range) of the air spring (f_s) should have been calculated on the Data Record Form using the following equation:

$$f_s = \frac{f_n}{\sqrt{L_r}}$$

Refer to the Suspension Geometry Section for further explanation of the above formula.

From the Dynamic Characteristics table in the Engineering Data section for each spring remaining, list the natural frequency (f_s) for each spring/design height combination at the

design load (L_d). Linear interpolation may be used to calculate f_s values if L_d falls between two tabulated loads. Eliminate from the remaining list those springs that will not be able to provide the necessary f_s at the design load (L_d). NOTE: For design heights that fall between the three tabulated values, use the data for the nearest value in the table. DO NOT interpolate between design heights.

If the desired natural frequency of the suspension system (f_n) is not known, it is not possible to eliminate any springs from the list. When the final air spring choice has been made, the frequency of the suspension system can be calculated by the following equation:

$$f_n = f_s \sqrt{L_r}$$

Step Seven-

Now consider the maximum air line pressure (P) available for the application with respect to the required air spring load (L_d). Turn to the Constant Pressure Load vs. Deflection curves for each remaining spring. Draw a horizontal line at the required L_d . Draw a vertical line(s) at the design height or design height range end points for the application. Choose for further consideration only those points, if any, along the L_d line that fall below the available pressure (P) curve. Interpolation can be used to approximate intermediate pressures.

Step Eight-

Note that while three design heights are shown in the Dynamic Characteristics table, only the middle design height data is plotted on the Dynamic Data Graph. For the purpose of this step, plot the required load (L_d) on the graph at the middle design height. Locate the corresponding design height pressure on the dynamic pressure curves above. If this pressure falls between the plotted curves, draw a "parallel" curve through the design height pressure point.

The endpoints of the curve should be drawn at heights corresponding to (DH - c) and (DH + e), again using only the middle design height regardless of whether or not it is the actual DH being considered. Data for the upper and lower ends of the design height range is contained in the Dynamic Characteristics table, but the Dynamic Data graph is valid only for the middle design height.

Repeat the above procedure for all springs remaining on the list. Generally, the spring that operates at the lowest pressure throughout its expected stroke should be chosen for the application. However, other factors may influence the decision (see Step Nine). Also, the spring with the lowest peak pressure may have surplus stroke capacity and therefore would not be the optimum choice. Technically, any spring remaining on the list may be chosen provided its peak pressure does not exceed 200 PSIG and its minimum pressure is not less than approximately 10 PSIG.

Step Nine-

From the Engineering Data, check for compatibility of environmental conditions with elastomers used. If any are incompatible, eliminate them from the list in Step Eight.

You now have the standard air springs that will best handle your application when properly applied. Application guidelines for air springs are outlined in our Do's and Don'ts of Air Spring Design and Application and in the Installation Guidelines Section. Final selection may be influenced by this as well as cost.

This Selection Procedure Section is designed to help you choose a spring from this catalog to best meet your needs. However, due to space limitations, not every popular air spring is listed in this catalog. OE production enables Veyance Technologies Inc. to design for other applications. If there is not a spring listed in the catalog that meets your requirements or you want help selecting a spring, contact Veyance Technologies, Inc. air spring product manager responsible for your specific application.

4. Sample Problem No. 1

Assume a trailer manufacturer is developing a new suspension for sliders and close-tandems that will give him a 19,000 lb. axle rating with a possible upgrade to a 20,500 lb. rating. The customer requires upward axle travel of 4.1" and downward axle travel of 3.5". The distance from the pivot to the axle is 20" while the distance from the pivot to the desired air spring location is 30". Also, the suspension geometry will limit the maximum allowable extended height of the air spring to 20". Although the vehicle's air compressor can provide up to 120 PSIG, the customer can only consider air line pressures up to 100 PSIG as required by Veyance Technologies, Inc. The desired natural frequency is 1.4-1.6 Hz. Finally, the customer does not wish to provide a jounce stop external to the air spring. Using two springs per axle, please provide the optimum air spring to meet this customer's requirements.

Step 1:

See completed Data Record Form. Note that h_c -max for the application is 20", so the maximum design height is therefore limited to 13.85", (20" - e = 13.85" where e = 6.15"). Also, in order to satisfy c = 5.25", the minimum compressed height cannot exceed 8.6" (13.85" - 5.25" = 8.6").

Data Record Form

1. Is an internal rubber bumper required? (Yes/No)	yes
2. The maximum weight (W) to be isolated	20,500 lb
3. The number of air springs (N) to be used	2
4. The diameter (d) of the space available at the air spring location	14.8 in
5. Required design height (DH) of the spring $DH_{\max} = 20 - e$	13.85 _{max} in
6. Air line pressure (P) available	100 PSIG
7. Required natural frequency (f_n) of the suspension	1.4-1.6 Hz
8. Maximum axle compression (AX_c)	3.5 in
9. Maximum axle extension (AX_e)	4.1 in
10. Pivot to wheel distance (D_w)	20 in
11. Pivot to spring distance (D_s)	30 in
12. Lever arm ratio ($L_r = D_s/D_w$)	1.5
13. Design load per air spring ($L_d = W/(N \times L_r)$)	6833 lb
14. Maximum spring compression required ($c = (AX_c)(L_r)$)	5.25 in
15. Maximum spring extension required ($e = (AX_e)(L_r)$)	6.15 in
16. Total spring stroke required ($S = e + c$)	11.40 in
17. Required compressed height of the spring ($h_c = DH - c$)	8.6 _{max} in
18. Required extended height of the spring ($h_e = DH + e$)	20 _{max} in
19. Required natural frequency of the spring ($f_s = f_n / \sqrt{L_r}$)	1.14- 1.31 Hz
20. Environmental conditions (temp., oil, chemicals, etc.)	None special

Step 2:

$d = 14.8"$, therefore $OD_{\max} = 12.8"$ or possibly slightly larger, say $13.0"$, based on judgement that $0.9"$ clearance will be adequate.

Step 3:

From the Nominal Operating Range Selection Chart, all large bellows and rolling lobes meet the height requirements at $L_d = 6833$ lb.

Step 4.1:

From the Selection Chart, the following large bellows and rolling lobes meet $OD_{\max} \leq 13.0"$:

Assy No.	MAX OD, 100 PSIG	Assy No.	MAX OD, 100 PSIG
1B9-202	11.0"	1R8-005	8.7"
2B9-200	10.3"	1R8-009	8.7"
2B9-201	10.3"	1R9-009	9.5"

2B9-216	10.3"	1R9-003	9.9"
2B9-250	10.3"	1R10-089	11.0"
2B9-251	10.3"	1R11-028	11.5"
2B9-253	10.3"	1R11-039	11.3"
1B12-313	13.2"	1R12-095	12.7"
2B12-309	13.0"	1R12-132	12.7"
2B12-425	13.0"	1R12-092	12.7"
2B12-429	13.0"	1R12-274	12.7"
3B12-304	13.0"	1R12-103	12.7"
3B12-305	13.0"	1R12-256	12.7"

Step 4.2:

From the Selection Chart and the list in Step 4.1, $L_d = 6833$ falls within the design load range for the following springs:

Assy No.	Design Load Range	Assy No.	Design Load Range
1B12-313	1215-8335 lb	1R11-039	1300-7055 lb
2B12-309	915-7205 lb	1R12-095	1360-7340 lb
2B12-425	915-7205 lb	1R12-132	1400-7815 lb
2B12-429	915-7205 lb	1R12-092	1320-7710 lb
3B12-304	860-7305 lb	1R12-274	1435-8055 lb
3B12-305	860-7305 lb	1R12-103	1325-7730 lb
		1R12-256	1390-7695 lb

Step 4.3:

From the Selection Chart and the list in Step 4.2, the following springs DO have bumpers:

Assy No.	Assy No.
2B12-309	1R12-092
1R11-039	1R12-274
1R12-095	1R12-103
1R12-132	1R12-256

Step 4.4:

From the Selection Chart and the list in Step 4.3, the following springs have possible design heights less than or equal to $13.85"$:

Assy No.	Design Height Range
2B12-309	7.5-9.5"
1R11-039	8.0-12.0"
1R12-095	7.0-9.0"
1R12-132	8.0-10.0"
1R12-092	10.5-16.5"
1R12-274	11.3-14.3"

Step 4.5:

From the Selection Chart and the list in Step 4.4, the following springs have strokes $\geq 11.4"$:

Assy No.	Usable Stroke
1R12-092	13.4"
1R12-274	14.7"

Step 4.6:

For the application, h_c is limited to 20". As the following table shows, neither of the two springs remaining can be eliminated because both are capable of meeting the 11.4" stroke requirements with $h_c < 20"$:

Assy No.	h_c -min	h_c -max	Required S	(h_c -min + S)
1R12-092	7.7"	21.1"	11.4"	19.1"
1R12-274	8.1"	22.8"	11.4"	19.5"

Step 5:

$c = 5.25"$, $e = 6.15"$. From the Dynamic Characteristic tables and the Selection Chart:

Assy No.	DH	h_c - min	h_c -max*	$h_c = DH - c$	$h_c = DH + e$
1R12-092	10.5"	7.7"	20.0"	5.25"	16.65"
	13.3"	7.7"	20.0"	8.05"	19.45"
	16.5"	7.7"	20.0"	11.25"	22.65"
1R12-274	11.3"	8.1"	20.0"	6.05"	17.45"
	12.8"	8.1"	20.0"	7.55"	18.95"
	14.3"	8.1"	20.0"	9.05"	20.45"

* h_c -max $\leq 20"$ is a constraint for this application.

After eliminating all spring/design height combinations where $h_c \leq h_c$ -min OR $h_c \geq h_c$ -max, the following remain:

Assy No.	DH	h_c - min	h_c -max*	$h_c = DH - c$	$h_c = DH + e$
1R12-092	13.3"	7.7"	20.0"	8.05"	19.45"

* h_c -max $\leq 20"$ is a constraint for this application.

Step 6:

Target $f_s = 1.14$ -1.31 Hz. From the Dynamic Characteristics tables in the Engineering Data section, the remaining spring has the following f_s values at $L_d = 6833$ lb at the applicable design height:

Assy No.	DH	f_s at 6833 lb**
1R12-092	13.3"	1.233 Hz

**Linear interpolation sample calculation:

$$\frac{7000 \text{ lb} - 6833 \text{ lb}}{7000 \text{ lb} - 6000 \text{ lb}} = \frac{1.23 \text{ Hz} - f_s}{1.23 \text{ Hz} - 1.25 \text{ Hz}}$$

$$f_s = 1.233 \text{ Hz}$$

Conclusion: 1R12-092 at 13.3" DH meets f_s requirement

Step 7:

From the Load vs. Deflection @ Constant Pressure curves for 1R12-092 at 13.3" DH, 6833 lb falls between the 80 and 100 PSIG curves at approx. 93 PSIG. Conclusion: OK

Step 8:

From the Dynamic Data @ 13.3" DH, curves for 1R12-092, and using $h_c = 8.05"$ (DH - c); and $h_c = 19.45"$ (DH + e), the pressure range is approx. 47 - 219 PSIG. Conclusion: OK.

Step 9:

There are no special environmental or other concerns, so it can be concluded that 1R12-092 at 13.3" DH is the optimum spring for the application.

Sample Problem No. 2 (Different pressure and lever arm ratios; no suspension constraint on extended height)

Assume a trailer manufacturer is developing a new suspension for sliders and close-tandems that will give him a 19,000 lb. axle rating with a possible upgrade to a 20,500 lb. rating. The customer requires upward axis travel of 4.1" and downward axle travel of 3.5". The distance from the pivot to the axle is 20", while the distance from the pivot to the desired air spring location is 36". The maximum allowable diameter-without causing interference is 14.8" at the air spring location. Although the vehicle's air compressor can provide up to 120 PSIG, the customer wishes to limit the air line pressure to 80 PSIG for possible flex life gains. The desired natural frequency is 1.4-1.6 Hz. Finally, the customer does not wish to provide a jounce stop external to the air spring. Using two springs per axis, please provide the optimum air spring to meet this customer's requirements.

Step 1:

See completed Data Record Form. Note that design height, h_c , and h_e are all unknown. Therefore, stroke (c, e, and S) will provide the major geometrical constraint in addition to diameter. Note also that P is limited to 80 PSIG and that L_r is 1.8 compared to P = 100 PSIG and $L_r = 1.5$ for Sample Problem No. 1. The larger L_r decreases design load to 5694 lb and increases S to 13.68".

Data Record Form

1. Is an internal rubber bumper required? (Yes/No)	yes
2. The maximum weight (W) to be isolated	20,500 lb
3. The number of air springs (N) to be used	2
4. The minimum diameter (d) of the space available at the air spring location	14.8 in
5. Required design height (DH) of the spring	unknown in
6. Air line pressure (P) available	80 PSIG
7. Required natural frequency (fn) of the suspension	1.4-1.6 Hz
8. Maximum axle compression (AX _c)	3.5 in
9. Maximum axle extension (AX _e)	4.1 in
10. Pivot to wheel distance (D _w)	20 in
11. Pivot to spring distance (D _s)	36 in
12. Lever arm ratio (L _r = D _s /D _w)	1.8
13. Design load per air spring (L _d = W/(N x L _r))	5694 lb
14. Maximum spring compression required (c = (AX _c)(L _r))	6.30 in
15. Maximum spring extension required (s = (AX _e)(L _r))	7.38 in
16. Total spring stroke required (S = e + c)	13.68 in
17. Required compressed height of the spring (h _c = DH - c)	unknown in
18. Required extended height of the spring (h _e = DH + e)	unknown in
19. Required natural frequency of the spring (f _s = f _n / √L _r)	1.04-1.19Hz
20. Environmental conditions (temp., oil, chemicals, etc.)	None special

Step 2:

d = 14.8" therefore OD_{max} = 12.8" or possibly slightly larger, say 13.0", based on judgement that 0.9" clearance will be adequate.

Step 3:

From the Nominal Operating Range Selection Chart, only large bellows and rolling lobes meet the requirements for L_d = 5694 lb. And from the table at the bottom of the same page, the Usable Stroke Range column shows that only rolling lobes are capable of at least 13.68" stroke.

Step 4.1:

From the Selection Chart, the following rolling lobes meet OD_{max} ≤ 13.0":

Assy No.	Max OD,100 PSIG	Assy No.	Max OD,100 PSIG
1R8-008	8.7"	1R12-095	12.7"
1R8-009	8.7"	1R12-132	12.7"
1R9-009	9.5"	1R12-092	12.7"
1R9-003	9.5"	1R12-274	12.7"
1R10-089	11.0"	1R12-103	12.7"
1R11-028	11.5"	1R12-256	12.7"
1R11-039	11.7"		

Step 4.2:

From the Selection Chart and the list in Step 4.1, L_n = 5694 falls within the design load range for the following springs:

Assy No.	Design Load Range	Assy No.	Design Load Range
1R10-089	1045-5970 lb	1R12-092	1320-7710 lb
1R11-028	1115-6795 lb	1R12-274	1435-8055 lb
1R11-039	1300-7055 lb	1R12-103	1325-7730 lb
1R12-095	1360-7340 lb	1R12-256	1390-7695 lb
1R12-132	1400-7815 lb		

Step 4.3:

From the Selection Chart and the list in Step 4.2, the following springs DO have bumpers:

Assy No.	Assy No.
1R11-039	1R12-274
1R12-095	1R12-103
1R12-132	1R12-256
1R12-092	

Step 4.4:

Since DH is not known, proceed to Step 4.5.

Step 4.5:

From the Selection Chart and the list in Step 4.3, the following springs have S ≥ 13.68":

Assy No.	Usable Stroke
1R12-274	14.7"
1R12-103	17.6"
1R12-256	19.6"

Step 4.6:

Since h_c and h_e are not known, proceed to Step 5.

Step 5:

$c = 6.30"$, $e = 7.38"$. From the Dynamic Characteristic tables and the Selection Chart:

Assy No.	DH	h_c -min	h_e -max	h_c =DH-c	h_e =DH+e
1R12-274	11.3"	8.1"	22.8"	5.00"	18.68"
	12.8"	8.1"	22.8"	6.50"	20.18"
	14.3"	8.1"	22.8"	8.00"	21.68"
1R12-103	15.0"	9.5"	27.0"	8.70"	22.38"
	16.3"	9.5"	27.0"	10.00"	23.68"
	20.0"	9.5"	27.0"	13.70"	27.38"
1R12-256	16.0"	9.5"	29.1"	9.70"	23.38"
	18.0"	9.5"	29.1"	11.70"	25.38"
	20.0"	9.5"	29.1"	13.70"	27.38"

After eliminating all spring/design height combinations where $h_c \leq h_c$ -min OR $h_e \geq h_e$ -max, the following remain:

Assy No.	DH	h_c -min	h_e -max	h_c =DH-c	h_e =DH+e
1R12-274	14.4"*	8.1"	22.8"	8.10"	21.68"
1R12-103	16.3"	9.5"	27.0"	10.00"	23.68"
1R12-256	20.0"	9.5"	27.0"	13.70"	27.38"
	16.0"	9.5"	29.1"	9.70"	23.38"
	18.0"	9.5"	29.1"	11.70"	25.38"
	20.0"	9.5"	29.1"	13.70"	27.38"

* Note: 1R12-274 will be considered at 14.4" DH, which is .10" above the official DH range for that spring.

Step 6:

Target $f_s = 1.04$ -1.19 Hz. From the Dynamic Characteristics tables in the Engineering Data section, the remaining springs have the following f_s values at $L_d = 5694$ lb at the applicable design height:

Assy No.	DH	f_s at 5694 lb*
1R12-274	14.4"	1.106 Hz
1R12-103	16.3"	1.186 Hz
	20.0"	0.906 Hz
	16.0"	1.126 Hz
1R12-256	18.0"	1.040 Hz
	20.0"	0.976 Hz

*Linear interpolation sample calculation:

$$\frac{6000 \text{ lb} - 5694 \text{ lb}}{6000 \text{ lb} - 5000 \text{ lb}} = \frac{1.18 \text{ Hz} - f_s}{1.18 \text{ Hz} - 1.20 \text{ Hz}}$$

$$f_s = 1.186 \text{ Hz}$$

Conclusion: The following springs meet $f_c = 1.04$ -1.19 at the design heights indicated:

Assy No.	DH	f_s at 5694 lb
1R12-274	14.4"	1.106 Hz
1R12-103	16.3"	1.186 Hz
1R12-256	16.0"	1.126 Hz
	18.0"	1.040 Hz

Step 7:

From the Load vs. Deflection @ Constant Pressure curves for the remaining spring/design height combinations, all of the springs listed in at the end of Step 6 fall below the 80 PSIG curve at $L_d = 5694$ lb.

Step 8:

From the Dynamic Data curves at $L_d = 5694$ lb. and using DH - c and DH + e to define the stroke limits, the remaining springs have the following pressure ranges ($c = 6.30"$, $e = 7.38"$):

Actual No.	Actual DH	Middle DH	Min Press (est)	Max Press (est)
1R12-274	14.4"	12.8"	38 PSIG	175 PSIG*
1R12-103	16.3"	16.3"	37 PSIG	173 PSIG
1R12-256	16.0"	18.0"	40 PSIG	155 PSIG
	18.0"	18.0"	40 PSIG	155 PSIG

*1R12-274 Max Press value extrapolated from off graph

Conclusion: The pressure ranges are similar for all remaining springs. Looking back to the S and h_e -max values for the three springs (see Selection Chart or Steps 4.5 and 5), 1R12-103 and 1R12-256 have considerably more stroke capability than is required for the application. The 1R12-274 seems more appropriately sized for the application, so it should be chosen with DH = 14.4", which is close enough to the listed design height range maximum of 14.3".

Step 9:

There are no special environmental or other concerns, so it can be concluded that 1R12-274 at 14.4" DH is the optimum spring for the application.

SUSPENSION GEOMETRY SECTION

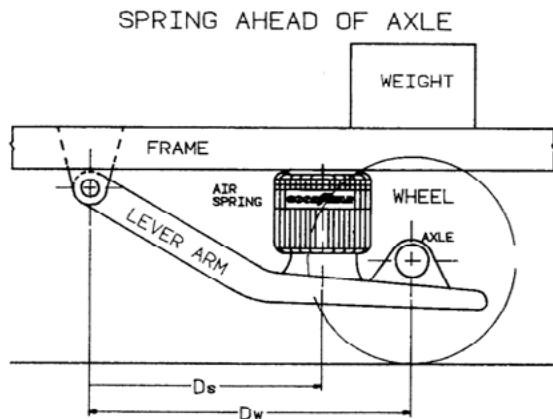

Definition of Variables:

f_n	= Natural frequency of the suspension system
f_s	= Natural frequency of the air spring
W	= Total weight of the sprung mass
N	= Number of air springs
D_w	= Distance from pivot to wheel centerline or point of applied load
D_s	= Distance from pivot to spring centerline
L_r	= Lever arm ratio
L_d	= Design load per air spring

Formula Explanations:

$L_r = D_s/D_w$... The lever arm ratio will vary on suspensions depending on whether the air spring is located ahead, behind, or directly over the axle centerline:

Ahead ... $L_r < 1$

Behind ... $L_r > 1$

Direct ... $L_r = 1$

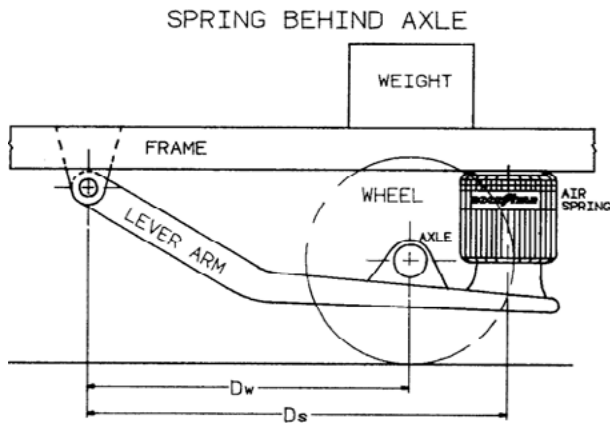

$L_d = W/(N \times L_r)$... The load per air spring is dependent on the number of air springs used and the placement of the air springs in the suspension in relation to the axle (lever arm ratio). By designing the suspension with the air spring located behind the axle centerline, you can decrease the load on the spring.

Ahead ... L_d increases

Behind ... L_d decreases

Direct ... L_d stays the same

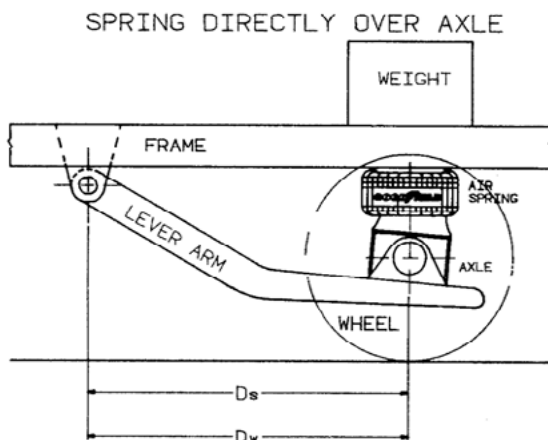

$f_s = f_n / \sqrt{L_r}$ The natural frequency of the suspension is also dependent on the placement of the air spring in relation to the axle (lever arm ratio). Given a load and design height, one can look up the spring's natural frequency (in the Dynamic Characteristics Table in the Engineering Data Section) and see how the location of the spring would affect the suspension's natural frequency:

Ahead ... f_n decreases

Behind ... f_n increases

Direct ... $f_n = f_s$

DO'S AND DON'TS OF DESIGN & APPLICATION

Do's

1. Allow clearance around the maximum diameter of the air spring to prevent abrasion of the flexible member on other structures. Where misalignment is not intended, one inch of clearance is generally sufficient.
2. Specify air spring assemblies with internal bumpers and/or install external stops to avoid:
 - a. Compression below the "compressed height without a bumper" for bellows. For rolling lobes & sleeve types, limit the compression to 0.1" above the "compressed height without a bumper".
 - b. Severe impacting at the "compressed height with no bumper".
 - c. Operation of vibrating equipment on the air spring assembly when it is deflated.
3. Install extension stops to limit the extension of the air spring to the maximum extended height.
4. When using an external bumper, check the load vs. deflection curve for bumper deflection height to insure compatibility of the air spring bumper and compressed height limits with the application.
5. For application using rolling lobe or sleeve type* air springs, a minimum of approximately 10 PSIG inflation pressure should be maintained. This insures that the flexible member will roll over the piston without buckling. Bellows air springs will maintain their operational configuration at zero pressure.
6. Use pipe dope or teflon tape around air fittings to insure against air leaks.
7. Install air springs with air port on the isolated end whenever possible.
8. Check the notes on the two page Engineering Data layouts of the selected assembly for other valuable information.
9. Consider environmental conditions such as temperature range, chemicals, etc. when choosing a Super-Cushion air spring for air actuation.

Don'ts

1. Do not exceed 200 PSIG internal pressure in compression or in any other condition.
2. Do not exceed the 100 PSIG maximum inflation pressure without application approval from Veyance Technologies, Inc., manufacturer of Goodyear Engineered Products.
3. Do not exceed the maximum extended height. To do so may cause structural damage to the air spring assembly.
4. Do not put the air spring assembly in torsion. Contact a Goodyear Engineered Products air springs representative if your application requires torsion.
5. Do not permit the Super-Cushion air spring to be compressed below its "compressed height with no bumper" in operation.
6. Do not allow a machine to continue to operate on a deflated air spring assembly. If deflation can occur, an internal bumper will help to protect the air spring assembly.
7. Do not mount a mass on a rolling lobe or sleeve type air spring without providing proper means of lateral stability.
8. Do not exhaust all of the air from a rolling lobe or sleeve type* air spring while attempting to compress it. A minimum of approximately 10 PSIG air pressure should be maintained internally. Not doing so may cause the flex member to buckle instead of rolling over the piston and may cause damage.
9. Do not allow harmful chemicals to contact the air spring. NOTE: The chemicals found in metal cutting processes have been found to be very harmful to the rubber and fabric used in air springs. These fluids are commonly called cutting coolant, and/or, cutting fluid. Do not allow them to contact the air spring.

ISOLATOR APPLICATION

10. Choose an air spring assembly for which the desired operating height and load are in the design height and design load range at inflation pressures between 20 and 100 PSIG.
11. Where possible, use design heights in the center of the design height range.
12. For increased lateral rate (stability) use 1B type bellows or use restraining cylinders with the rolling lobe and sleeve type assemblies.
13. Inflate with air or nitrogen.

* The 1S3-013 is an exception. It will roll down at 0 PSIG.

GENERAL DESIGN CONSIDERATIONS

In a Super-Cushion air spring the ability to support a load or to produce a linear force depends on the effective area of the air spring.

The relationship between effective area (A_e) in square inches, force or load (L) in pounds, and air pressure (P) in pounds per square inch (gauge) is illustrated in the following equation:

$$L = P \times A_e$$

It is important to note that the effective area (A_e) decreases with increasing height or increasing stroke of a bellows (B) type air spring. This means that the load-carrying ability of the bellows type decreases with increasing height or stroke.

This can be easily seen by studying the Constant Pressure Data provided in the Engineering Data Section.

Effective area is generally not constant over the entire stroke range for the rolling lobe (R) or sleeve (S) types; however, it is usually more constant over part of the stroke, thus providing a relatively constant load over that part of the stroke for a given pressure. Again, refer to the Constant Pressure Data in the Engineering Data Section.

INSTALLATION GUIDELINES

Installation Instructions

All air spring applications require adequate support of both upper and lower end components. Although it is recommended to fully support the air springs to the diameter of the attaching end metals, it is not always required. If your application does not allow for full support, contact a Goodyear Engineered Products air springs representative for design assistance.

In the case of arcuate motion, the best results occur when the upper and lower components are parallel at the air spring's bumper contact height. A small reverse angle at this position may be designed in to reduce the angle at maximum spring extension. For bellows, the convolutions must separate as the air spring approaches maximum extension to prevent excessive abrasion. Do Not exceed the Maximum Extended Height of the spring as measured on the outside of the arcuate path.

When designing for the use of air springs, care must be taken to ensure that no sharp edges will contact the flexible member throughout the full travel of the air spring. This must be verified for both maximum inflation and zero pressure operation, especially for rolling lobe and sleeve type rolling lobe springs where the clearance between the meniscus and the piston support surface decreases as the pressure decreases. The space envelope around the air spring must clear the maximum outside diameter of the air spring by two inches (one inch on all sides) to allow for normal growth as well as deformity caused by misalignment.

Excessive loading may occur on the air spring assembly when adequate height clearance is not maintained with external stops. Built-in compression stops (rubber bumpers) are available with various load vs. deflection characteristics. However, external mechanical stops are recommended whenever possible to prevent end metal deformation.

Special cases occur with the three convolution bellows (3B) air springs under certain load and deflection conditions. In order to maintain stability over the entire stroke of a 3B air spring, it must be fully supported to the maximum outside diameter of the air spring. Also, the end retainers must either

be recessed approximately 0.75" into the supporting surfaces, or attached with special rubber rings that fit around the outside diameter of the retainers. Contact a Goodyear Engineered Products air springs representative for design assistance.

Special Consideration for Sleeve Type Bellows

When operating the following air springs at or below the heights listed in the table, caution must be taken to avoid flexible member contact with obstructions. The air springs should either be mounted with a flat plate on both the upper and lower retainers, or on a pedestal (see figure below). Dimensions for the plates and pedestals are specified in the table.

	1B5-520	1B6-535	1B8-560
Operating Height	2.8"	3.5"	3.3"
Plate Diameter	6.75"	7.25"	9.65"
Pedestal Height	1.8"	1.7"	1.5"
Pedestal Diameter	3.25"	4.00"	5.00"

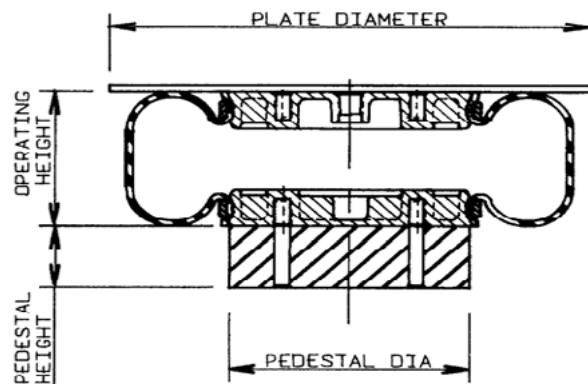

PEDESTAL REQUIRED WHEN OPERATING SPRING AT OR BELOW HEIGHTS LISTED IN THE TABLE

NOMINAL OPERATING RANGE SELECTION GRAPH

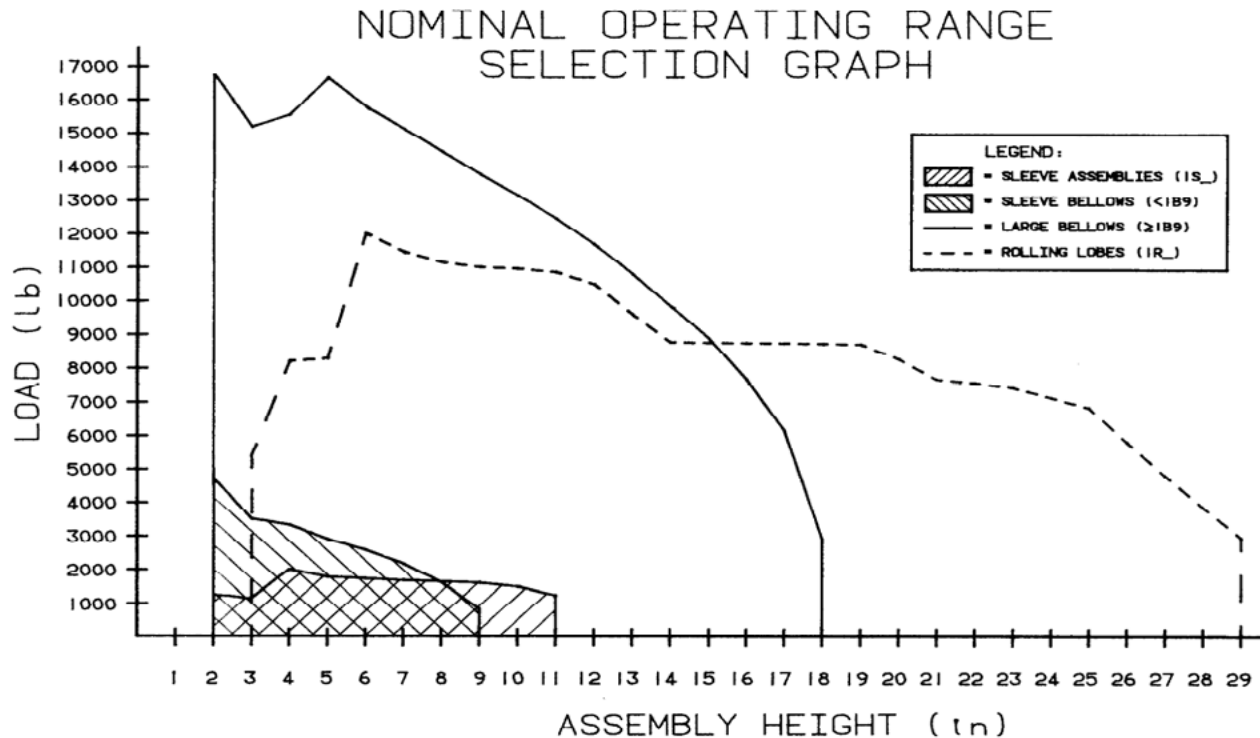

How to Use This Graph:

Draw a horizontal line at the desired load per air spring. If the line crosses a region, then the corresponding family of springs is a possibility for the design application. If the stroke

and/or the design height of the application is known, then the spring selection process can be narrowed by drawing vertical lines at the necessary assembly height limits. The resulting line segment must fall entirely within the region to consider that product group for the application.

PRODUCT GROUP	ASSEMBLY HEIGHT RANGE (in)	USEABLE STROKE RANGE (in)	DESIGN HEIGHT RANGE (in)	FORCE TO COMPRESS RANGE (lb)	LATERAL STABILITY	FREQUENCY RANGE (Hz)
SLEEVE ASSEM's	1.5-10.9	2.1-6.8	2.0-9.0	N/A	LOW	1.12-4.30
SLEEVE BELLOWS	1.8-9.0	2.0-6.5	2.5-8.0	5-40	LOW TO MODERATE	1.90-3.8
LARGE BELLOWS	2.3-18.0	3.6-13.3	3.2-15.0	5-165	MODERATE TO STIFF	1.30-3.0
ROLLING LOBES	3.2-29.1	8.6-19.6	6.0-20.0	N/A	LOW	0.68-2.23

Appendix A

Data Record Form

1. Is an internal rubber bumper required? (Yes/No)
2. The maximum weight (W) to be isolatedlb
3. The number of air springs (N) to be used
4. The diameter (d) of the space available at the air spring locationin
5. Required design height (DH) of the springin
6. Air line pressure (P) availablePSIG
7. Required natural frequency (f_n) of the suspensionHz
8. Maximum axle compression (AX_c)in
9. Maximum axle extension (AX_e)in
10. Pivot to wheel distance (D_w)in
11. Pivot to spring distance (D_s)in
12. Lever arm ratio ($L_r = D_s/D_w$)
13. Design load per air spring ($L_d = W/(N \times L_r)$)lb
14. Maximum spring compression required ($c = (AX_c)(L_r)$)in
15. Maximum spring extension required ($e = (AX_e)(L_r)$)in
16. Total spring stroke required ($S = e + c$)in
17. Required compressed height of the spring ($h_c = DH - c$)in
18. Required extended height of the spring ($h_e = DH + e$)in
19. Required natural frequency of the spring ($f_s = f_n / \sqrt{L_r}$)Hz
20. Environmental conditions (temp., oil, chemicals, etc.)

The GOODYEAR (and Winged Foot Design) trademark is used by Veyance Technologies, Inc. under license from The Goodyear Tire & Rubber Company. Goodyear Engineered Products are manufactured and sourced exclusively by Veyance Technologies, Inc. or its affiliates. The following trademarks are licensed to Veyance Technologies, Inc. by The Goodyear Tire & Rubber Company, including Compass, Eagle Pd, Flexten, Gatorback and GY Metric. ©2008 Veyance Technologies, Inc. All Rights Reserved.



SELECTION CHART FOR SUPER-CUSHION® AIR SPRING ACTUATORS

Here is a brief explanation of the Selection Chart that follows:

1. The three-page selection chart on the following pages covers the specifications for Super-Cushion air springs used as actuators.
2. Where bellows air springs are listed, the same specifications are listed under the headings; “Max. Outside Diameter” and “Max. Extended Height” for each bellows air spring using the

same flexible member. Variations in “Compressed Height” and “Useable Stroke” are produced when an internal bumper is specified.

The shaded areas below the initial entry for a specific bellows air spring represent optional air fitting accommodations and bumpers as listed.

SELECTION CHART FOR SUPER-CUSHION® AIR SPRING ACTUATORS

Assembly Number	Max OD @ 100 PSIG (Inches)	Useable Stroke (Inches)	Min Compr. Height (Inches)	Max Ext. Height (Inches)	Bumper Included	Force Available At Actuator Height Limit (Pounds)				Force Available At Compressed Height (Pounds)				Air Fitting Size (Inches)
						@ 100 PSIG	@ 80 PSIG	@ 60 PSIG	@ 40 PSIG	@ 100 PSIG	@ 80 PSIG	@ 60 PSIG	@ 40 PSIG	
1S3-011	3.25	4.4	3.6	8.0	NO	110	80	60	50	360	280	200	130	1/8 CS
1S3-013	3.6	2.1	1.5	3.6	NO	120	80	40	30	600	480	360	240	1/8 CS
1S4-007	4.6	4.9	2.2	7.1	NO	310	240	180	130	1100	900	700	520	1/8 CS
1S4-008	4.6	6.5	4.0	10.5	NO	540	420	340	250	850	700	520	340	1/8 CS
1S5-010	5.6	4.0	2.2	6.2	NO	560	440	320	240	1250	950	700	460	1/8 CS
1S5-005	5.7	5.5	4.0	9.5	NO	800	660	500	340	950	750	540	360	1/8 CS
1S5-006	5.6	6.5	4.0	10.5	NO	750	600	460	320	1100	850	660	420	1/8 CS
1S6-023	7.0	6.8	4.1	10.9	NO	1200	950	700	480	2000	1500	1100	750	1/8 CS
1B5-500	5.7	2.0	1.8	3.8	NO	560	400	280	170	1500	1200	900	580	1/4 C
1B5-502	5.7	2.0	1.8	3.8	NO	560	400	280	170	1500	1200	900	580	3/4 C
1B5-503	5.7	2.0	1.8	3.8	NO	560	400	280	170	1500	1200	900	580	1/4 TV
1B5-510	6.0	3.0	1.8	4.8	NO	520	380	260	140	1600	1250	950	620	1/4 C
1B5-512	6.0	3.0	1.8	4.8	NO	520	380	260	140	1600	1250	950	620	3/4 C
1B5-520*	6.5	3.0*	1.8*	5.8	NO	440	300	180	80	2100	1600	1200	850	1/4 C
1B5-521*	6.5	3.0*	1.8*	5.8	NO	440	300	180	80	2100	1600	1200	850	3/4 C
1B6-530	6.5	2.8	2.0	4.8	NO	850	620	440	230	2000	1600	1200	800	1/4 C
1B6-531	6.5	2.8	2.0	4.8	NO	850	620	440	230	2000	1600	1200	800	1/4 OS
1B6-532	6.5	2.5	2.3	4.8	YES	850	620	440	230	2000	1600	1200	800	1/4 OS
1B6-535*	7.0	5.1*	2.0*	7.1	NO	750	500	300	140	3000	2300	1800	1250	1/4 C
1B6-536*	7.0	5.1*	2.0*	7.1	NO	750	500	300	140	3000	2300	1800	1250	1/4 OS
2B6-530**	6.5	4.5**	2.8	7.7	NO	580	380	220	90	2800	2300	1700	1200	1/4 C
2B6-531**	6.5	4.5**	2.8	7.7	NO	580	380	220	90	2800	2300	1700	1200	1/4 OS
2B6-532	6.5	4.3	3.4	7.7	YES	580	380	220	90	2400	1900	1400	950	1/4 OS
2B6-535**	7.0	5.9**	2.8	9.1	NO	560	380	200	80	3300	2700	2100	1500	1/4 OS
2B6-536	7.0	5.7	3.4	9.1	YES	560	380	200	80	3000	2400	1800	1250	1/4 OS
1B7-540	7.7	3.2	2.0	5.2	NO	850	600	350	200	2600	2000	1500	1000	1/4 C
1B7-541	7.7	3.2	2.0	5.2	NO	850	600	350	200	2600	2000	1500	1000	1/4 OS
1B7-542	7.7	2.9	2.3	5.2	YES	850	600	350	200	2500	2000	1450	950	1/4 OS
2B7-540	8.0	6.5	2.5	9.0	NO	800	540	280	110	3200	2500	1800	1200	1/4 C
2B7-541	8.0	6.5	2.5	9.0	NO	800	540	280	110	3200	2500	1800	1200	1/4 OS
2B7-542	8.0	5.7	3.3	9.0	YES	800	540	280	110	3100	2400	1800	1200	1/4 OS
2B7-546	8.0	6.5	2.5	9.0	NO	800	540	280	110	3200	2500	1800	1200	3/4 C
1B8-550	8.7	3.3	2.0	5.3	NO	1100	800	550	300	3600	2800	2100	1350	1/4 C
1B8-552	8.7	3.3	2.0	5.3	NO	1100	800	550	300	3600	2800	2100	1350	3/4 C
1B8-553	8.7	3.3	2.0	5.3	NO	1100	800	550	300	3600	2800	2100	1350	1/4 OS
1B8-554	8.7	3.0	2.3	5.3	YES	1100	800	550	300	3500	2800	2100	1350	1/4 OS
1B8-560*	9.4	3.2*	2.0*	6.7	NO	1600	1200	750	450	4500	3500	2500	1650	1/4 C
1B8-562*	9.4	3.2*	2.0*	6.7	NO	1600	1200	750	450	4500	3500	2500	1650	3/4 C
1B8-563*	9.4	3.2*	2.0*	6.7	NO	1600	1200	750	450	4500	3500	2500	1650	1/4 OS
2B8-550**	8.8	6.9**	2.9	10.1	NO	1000	700	450	180	5000	4100	3100	2100	1/4 C
2B8-552**	8.8	6.9**	2.9	10.1	NO	1000	700	450	180	5100	4100	3100	2100	3/4 C
2B8-553**	8.8	6.9**	2.9	10.1	NO	1000	700	450	180	5100	4100	3100	2100	1/4 OS
2B8-554	8.8	6.6	3.5	10.1	YES	1000	700	450	180	4600	3700	2800	1900	1/4 OS
1B9-201	11.0	2.0	3.2	5.2	YES	3005	2378	1756	1167	5100	4000	3000	2000	1/4 OS
1B9-202	11.0	3.0	2.2	5.2	NO	3005	2378	1756	1167	5624	4500	3347	2219	1/4 OS

NOTE: TV = TANK VALVE, OS = OFFSET (FROM CTR), C = CENTERED, CS = COMBO STUD

* SEE INSTALLATION GUIDELINES AND DRAWING

** BASED ON 3.2" COMPRESSED HEIGHT. SEE DRAWING.

***ALTERNATIVE LIMITS WITH PEDESTAL MOUNT, SEE DRAWING

SELECTION CHART FOR SUPER-CUSHION® AIR SPRING ACTUATORS

Assembly Number	Max OD @ 100 PSIG (Inches)	Useable Stroke (Inches)	Min Compr. Height (Inches)	Max Ext. Height (Inches)	Bumper Included	Force Available At Actuator Height Limit (Pounds)				Force Available At Compressed Height (Pounds)				Air Fitting Size (Inches)
						@ 100 PSIG	@ 80 PSIG	@ 60 PSIG	@ 40 PSIG	@ 100 PSIG	@ 80 PSIG	@ 60 PSIG	@ 40 PSIG	
1B9-204	11.0	3.0	2.2	5.2	NO	3005	2378	1756	1167	5624	4500	3347	2219	1/2 OS
1B9-205	11.0	2.0	3.2	5.2	YES	3005	2378	1756	1167	5100	4000	3000	2000	1/2 OS
1B9-207	11.0	3.0	2.2	5.2	NO	3005	2378	1756	1167	5624	4500	3347	2219	3/4 OS
1B9-208	11.0	2.0	3.2	5.2	YES	3005	2378	1756	1167	5100	4000	3000	2000	3/4 OS
2B9-200	10.3	6.3	3.2	9.5	NO	2965	2330	1670	1055	5700	4500	3300	2100	1/4 OS
2B9-201	10.3	5.7	3.8	9.5	YES	2965	2330	1670	1055	5200	4200	3000	1900	1/4 OS
2B9-204	10.3	6.3	3.2	9.5	NO	2965	2330	1670	1055	5700	4500	3300	2100	1/2 OS
2B9-205	10.3	5.7	3.8	9.5	YES	2965	2330	1670	1055	5200	4200	3000	1900	1/2 OS
2B9-208	10.3	5.7	3.8	9.5	YES	2965	2330	1670	1055	5200	4200	3000	1900	3/4 OS
2B9-216	10.3	6.3	3.2	9.5	NO	2965	2330	1670	1055	5700	4500	3300	2100	3/4 OS
2B9-250	10.3	7.2	3.5	10.7	NO	2924	2285	1674	1081	6000	4700	3600	2400	1/4 OS
2B9-251	10.3	6.9	3.8	10.7	YES	2924	2285	1674	1081	5800	4500	3500	2300	1/4 OS
2B9-253	10.3	6.9	3.8	10.7	YES	2924	2285	1674	1081	5800	4500	3500	2300	1/4 OS
2B9-255	10.3	6.9	3.8	10.7	YES	2924	2285	1674	1081	5800	4500	3500	2300	1/4 OS
2B9-256	10.3	7.2	3.5	10.7	NO	2924	2285	1674	1081	6000	4700	3600	2400	1/4 OS
2B9-263	10.3	7.2	3.5	10.7	NO	2924	2285	1674	1081	6000	4700	3600	2400	1/2 OS
2B9-275	10.3	7.2	3.5	10.7	NO	2924	2285	1674	1081	6000	4700	3600	2400	3/4 OS
1B12-301	13.2	3.0	2.6	5.6	YES	6584	5145	3676	2469	9000	7000	5200	3400	1/4 OS
1B12-304	13.2	3.3	2.3	5.6	NO	6584	5145	3676	2469	9100	7100	5300	3500	3/4 OS
1B12-305	13.2	3.0	2.6	5.6	YES	6584	5145	3676	2469	9000	7000	5200	3400	3/4 OS
1B12-313	13.2	3.3	2.3	5.6	NO	6584	5145	3676	2469	9100	7100	5300	3500	1/4 OS
2B12-309	13.0	5.3	4.2	9.5	YES	3120	2360	3676	2469	9100	7200	5300	3400	1/4 OS
2B12-318	13.0	5.3	4.2	9.5	YES	3120	2360	3676	2469	9100	7200	5300	3400	3/4 OS
2B12-425	13.0	6.1	3.4	9.5	NO	3120	2360	3676	2469	9400	7400	5500	3500	1/4 OS
2B12-429	13.0	6.1	3.4	9.5	NO	3120	2360	3676	2469	9400	7400	5500	3500	3/4 OS
2B12-437	13.0	6.1	3.4	9.5	NO	3120	2360	3676	2469	9400	7400	5500	3500	1/4 C
2B12-416***	13.7	8.4***	4.3***	12.7	NO	4500	3400	2400	1400	10000	7800	5800	3800	1/4 OS
2B12-419***	13.7	8.4***	4.3***	12.7	NO	4500	3400	2400	1400	10000	7800	5800	3800	3/4 OS
2B12-440***	13.7	8.4***	4.3***	12.7	YES	4500	3400	2400	1400	10000	7800	5800	3800	1/4 CS
3B12-304	12.9	10.6	4.8	15.4	NO	4600	3800	2700	1700	10000	7900	5800	3900	1/4 OS
3B12-305	12.9	10.6	4.8	15.4	NO	4600	3800	2700	1700	10000	7900	5800	3900	3/4 OS
3B12-308	12.9	10.6	4.8	15.4	NO	4600	3800	2700	1700	10000	7900	5800	3900	1/4 C
3B12-325	13.8	11.1	4.6	15.7	NO	5800	4500	3300	2100	11500	9100	6700	4400	1/4 OS
3B12-326	13.8	11.1	4.6	15.7	NO	5800	4500	3300	2100	11500	9100	6700	4400	3/4 OS
1B14-350	15.2	3.3	2.3	5.6	NO	9300	7300	5400	3500	13300	10500	7900	5200	1/4 OS
1B14-351	15.2	1.4	4.2	5.6	YES	9300	7300	5400	3500	11700	9200	6900	4600	1/4 OS
1B14-352	15.2	3.3	2.3	5.6	NO	9300	7300	5400	3500	13300	10500	7900	5200	3/4 OS
1B14-353	15.2	1.4	4.2	5.6	YES	9300	7300	5400	3500	11700	9200	6900	4600	3/4 OS
1B14-362	15.9	3.7	2.8	6.5	NO	9500	7400	5500	3600	13980	11051	8265	5471	3/4 OS
1B14-364	15.9	3.7	2.8	6.5	NO	9500	7400	5500	3600	13980	11051	8265	5471	1/4 OS
2B14-352	15.1	6.0	3.7	9.7	NO	7900	6500	4600	3000	13700	10900	8100	5350	3/4 OS
2B14-353	15.1	4.8	4.9	9.7	YES	7900	6500	4600	3000	13100	10500	7800	5200	3/4 OS
2B14-354	15.1	6.0	3.7	9.7	NO	7900	6500	4600	3000	13900	11000	8200	5400	1/4 OS
2B14-355	15.1	4.8	4.9	9.7	YES	7900	6500	4600	3000	13200	10615	7904	5259	1/4 OS
2B14-362***	16.0	8.0***	4.5***	12.5	NO	9100	6800	4800	3000	15700	12000	8800	5700	1/4 OS

NOTE: TV = TANK VALVE, OS = OFFSET (FROM CTR), C = CENTERED, CS = COMBO STUD

* SEE INSTALLATION GUIDELINES AND DRAWING

** BASED ON 3.2" COMPRESSED HEIGHT. SEE DRAWING.

***ALTERNATIVE LIMITS WITH PEDESTAL MOUNT, SEE DRAWING

SELECTION CHART FOR SUPER-CUSHION® AIR SPRING ACTUATORS

Assembly Number	Max OD @ 100 PSIG (Inches)	Useable Stroke (Inches)	Min Compr. Height (Inches)	Max Ext. Height (Inches)	Bumper Included	Force Available At Actuator Height Limit (Pounds)				Force Available At Compressed Height (Pounds)				Air Fitting Size (Inches)	
						@ 100 PSIG	@ 80 PSIG	@ 60 PSIG	@ 40 PSIG	@ 100 PSIG	@ 80 PSIG	@ 60 PSIG	@ 40 PSIG		
2B14-363***	16.0	8.0***	4.5***	12.5	NO	9100	6800	4800	3000	15700	12000	8800	5700	3/4	OS
2B14-452***	16.0	8.0***	4.5***	12.5	YES	9100	6800	4800	3000	15900	12300	9000	5900	1/4	OS
3B14-351	15.5	7.9	7.3	15.2	YES	8300	6300	4500	2800	13800	10500	7700	5100	1/4	OS
3B14-353	15.5	7.9	7.3	15.2	YES	8300	6300	4500	2800	13800	10500	7700	5100	3/4	OS
3B14-354	15.5	10.2	5.0	15.2	NO	8300	6300	4500	2800	15200	11000	8200	5400	1/4	OS
3B14-361	15.5	10.2	5.0	15.2	NO	8300	6300	4500	2800	15200	11000	8200	5400	3/4	OS
3B14-403	15.5	10.2	5.0	15.2	NO	8300	6300	4500	2800	15200	11000	8200	5400	1/4	OS
3B14-374	15.5	15.8	4.7	20.5	NO	4500	3300	2000	900	15000	11800	8800	5800	3/4	OS
3B14-411	15.5	15.6	4.9	20.5	YES	4500	3300	2000	900	14800	11600	8600	5700	3/4	OS
3B14-450	15.5	15.8	4.7	20.5	NO	4500	3300	2000	900	15000	11800	8800	5800	1/4	OS
3B14-453	15.5	15.6	4.9	20.5	YES	4500	3300	2000	900	14800	11600	8600	5700	1/4	OS
1B15-375	17.5	3.5	2.3	5.8	NO	11300	8900	6500	4200	16700	13400	9600	6500	1/4	OS
1B15-376	17.5	1.6	4.2	5.8	YES	11300	8900	6500	4200	13900	11100	8200	5400	1/4	OS
1B15-377	17.5	3.5	2.3	5.8	NO	11300	8900	6500	4200	16700	13400	9600	6500	3/4	OS
1B15-378	17.5	1.6	4.2	5.8	YES	11300	8900	6500	4200	13900	11100	8200	5400	3/4	OS
2B15-375	16.5	6.6	3.7	10.3	NO	9000	7200	5400	3500	15100	12100	9000	5800	1/4	OS
2B15-376	16.5	5.4	4.9	10.3	YES	9000	7200	5400	3500	14000	11200	8400	5400	1/4	OS
2B15-377	16.5	6.6	3.7	10.3	NO	9000	7200	5400	3500	15100	12100	9000	5800	3/4	OS
2B15-378	16.5	5.4	4.9	10.3	YES	9000	7200	5400	3500	14000	11200	8400	5400	3/4	OS
3B15-375	16.5	9.9	4.7	14.6	NO	9200	7100	5400	3500	16500	13200	9700	6500	1/4	OS
3B15-376	16.5	7.3	7.3	14.6	YES	9200	7100	5400	3500	14800	11800	8900	5900	1/4	OS
3B15-377	16.5	9.9	4.7	14.6	NO	9200	7100	5400	3500	16500	13200	9700	6500	3/4	OS
3B15-378	16.5	7.3	7.3	14.6	YES	9200	7100	5400	3500	14800	11800	8900	5900	3/4	OS
2B19-8423	20.5	8.75	3.25	12.0	NO	10700	8000	5400	3100	27500	21900	16400	10900		
2B19-8433	20.5	8.75	3.25	12.0	NO	10700	8000	5400	3100	27500	21900	16400	10900		
2B22-8529	23.0	9.25	3.25	12.5	NO	14800	11100	7700	4500	35300	28100	21000	13800		
2B22-8539	23.0	9.25	3.25	12.5	NO	14800	11100	7700	4500	35300	28100	21000	13800		
1R8-005	8.7	12.8	5.8	18.6	NO	--	900	640	380	5000	4100	3200	2400	1/4	CS
1R8-009	8.7	11.8	6.8	18.6	YES	--	850	560	360	3900	3200	2500	1600	1/4	CS
1R9-003	9.5	12.3	5.6	17.9	NO	1250	900	640	400	4900	3900	2900	2000	1/4	CS
1R9-009	9.5	8.6	3.2	11.8	NO	900	700	500	330	5300	4400	3400	2600	1/4	CS
1R10-089	11.0	14.1	6.0	20.1	NO	2100	1500	950	580	7300	5800	4400	2900	1/4	CS
1R11-028	11.5	9.3	3.7	13.0	NO	2300	1800	1100	460	8300	6700	5100	3600	1/4	CS
1R11-039	11.3	10.9	6.1	17.0	YES	2300	1800	1350	900	7900	6300	4900	3300	1/4	CS
1R12-092	12.7	13.4	7.7	21.1	YES	2700	1700	1200	620	8100	6400	4700	3200	1/4	CS
1R12-095	12.7	9.1	4.4	13.5	YES	2400	1700	1000	400	8600	6800	5100	3300	1/4	CS
1R12-103	12.7	17.6	9.4	27.0	YES	2600	1800	980	400	8200	6500	4700	3100	1/4	CS
1R12-132	12.7	10.8	6.1	16.9	YES	2700	1900	1200	620	8400	6700	5000	3300	1/4	CS
1R12-256	12.7	19.6	9.5	29.1	YES	3100	2200	1500	850	9000	7100	5100	3400	1/4	CS
1R12-274	12.7	14.7	8.1	22.8	YES	3000	2200	1450	750	9000	7200	5200	3500	1/4	CS
1R14-018	14.6	14.8	7.7	22.5	YES	2500	2000	1250	680	10300	8300	6600	4700	1/4	OS
1R14-019	14.6	16.9	8.9	25.8	YES	2000	1300	800	10100	8000	6000	4200	1/4	OS
1R14-037	14.8	12.3	5.7	18.0	YES	2900	2200	1500	950	12200	9800	7300	4700	1/4	OS

NOTE: TV = TANK VALVE, OS = OFFSET (FROM CTR), C = CENTERED, CS = COMBO STUD

* SEE INSTALLATION GUIDELINES AND DRAWING

** BASED ON 3.2" COMPRESSED HEIGHT. SEE DRAWING.

***ALTERNATIVE LIMITS WITH PEDESTAL MOUNT, SEE DRAWING

The GOODYEAR (and Winged Foot Design) trademark is used by Veyance Technologies, Inc. under license from The Goodyear Tire & Rubber Company. Goodyear Engineered Products are manufactured and sourced exclusively by Veyance Technologies, Inc. or its affiliates. The following trademarks are licensed to Veyance Technologies, Inc. by The Goodyear Tire & Rubber Company, including Compass, Eagle Pd, Flexten, Gatorback and GY Metric. ©2008 Veyance Technologies, Inc. All Rights Reserved.



SELECTION CHART FOR SUPER-CUSHION® AIR SPRING ISOLATORS

Here is a brief explanation of the Selection Chart that follows:

1. The two-page selection chart on the following pages covers the specifications for Super-Cushion air springs used as isolators in vehicular applications.
2. Where bellows air springs are listed, the same specifications are listed under the headings; “Max. Outside Diameter” and “Max. Extended Height” for each bellows air spring using the same flexible member. Variations in “Compressed Height” and “Useable Stroke” are produced when an internal bumper is specified.

The shaded areas below the initial entry for a specific bellows air spring represent optional air fitting accommodations and bumpers as listed.

3. In the selection chart there is a column titled; “Approximate Isolation Percent.” The figures in this column reflect the approximate percentage of isolation obtainable if the design height is at the center of the design height range, and the load per air spring is within the design load range. If the design height is above or below the design height range, vibration isolation may be slightly higher or lower, respectively.

SELECTION CHART FOR SUPER-CUSHION® AIR SPRING ISOLATORS

Assembly Number	Max OD @100 PSIG (Inches)	Design Load Range (Pounds)	Design Height Range (inches)	Usable Stroke (Inches)	Min Comp Height (Inches)	Max Ext Height (Inches)	Bumper Included	Approximate Isolation Percent For a Disturbing Frequency Of:				Air Fitting Size (Inches)
								435 CPM	870 CPM	1160 CPM	1750 CPM	
1S3-013	3.6	90-580	2.0-3.0	2.1	1.5	3.6	NO	71.0	93.0	96.3	98.2	1/8 CS
1S3-011	3.25	70-400	5.0-6.0	4.4	3.6	8.0	NO	92.0	97.8	98.7	99.5	1/8 CS
1S4-007	4.6	160-850	3.8-4.4	4.9	2.2	7.1	NO	90.0	97.4	98.4	99.3	1/8 CS
1S4-008	4.6	150-800	6.5-7.5	6.5	4.0	10.5	NO	95.0	98.5	99.2	99.6	1/8 CS
1S5-010	5.6	180-1100	3.8-4.3	4.0	2.2	6.2	NO	90.0	97.5	98.5	99.4	1/8 CS
1S5-005	5.7	170-1100	6.2-7.2	5.5	4.0	9.5	NO	95.0	98.6	99.2	99.6	1/8 CS
1S5-006	5.6	190-1150	7.0-9.0	6.5	4.0	10.5	NO	96.0	99.0	99.3	99.7	1/8 CS
1S6-023	7.0	260-1600	7.0-8.6	6.8	4.1	10.9	NO	94.0	98.4	99.1	99.6	1/8 CS
1B5-500	5.7	210-1350	2.5-3.0	2.0	1.8	3.8	NO	72.0	94.0	96.3	98.3	1/4 C
1B5-502	5.7	210-1350	2.5-3.0	2.0	1.8	3.8	NO	72.0	94.0	96.3	98.3	3/4 C
1B5-503	5.7	210-1350	2.5-3.0	2.0	1.8	3.8	NO	72.0	94.0	96.3	98.3	1/4 TV
1B5-510	6.0	190-1500	2.5-4.0	3.0	1.8	4.8	NO	82.0	96.0	97.5	99.0	1/4 C
1B5-512	6.0	190-1500	2.5-4.0	3.0	1.8	4.8	NO	82.0	96.0	97.5	99.0	3/4 C
1B5-520	6.5	190-1500	3.5-5.0	4.0	1.8	5.8	NO	83.0	96.2	97.6	99.0	1/4 C
1B5-521	6.5	190-1500	3.5-5.0	4.0	1.8	5.8	NO	83.0	96.2	97.6	99.0	3/4 C
1B6-530	6.5	280-1900	3.0-4.0	2.8	2.0	4.8	NO	78.0	95.0	97.0	98.6	1/4 C
1B6-531	6.5	280-1900	3.0-4.0	2.8	2.0	4.8	NO	78.0	95.0	97.0	98.6	1/4 OS
1B6-532	6.5	280-1900	3.0-4.0	2.5	2.3	4.8	YES	78.0	95.0	97.0	98.6	1/4 OS
1B6-535	7.0	250-2100	4.0-6.0	5.3	2.0	7.1	NO	90.0	97.4	98.4	99.3	1/4 C
1B6-536	7.0	250-2100	4.0-6.0	5.3	2.0	7.1	NO	90.0	97.4	98.4	99.3	1/4 OS
1B6-538	7.0	250-2100	4.0-6.0	4.8	2.3	7.1	YES	90.0	97.4	98.4	99.3	1/4 OS
2B6-530	6.5	180-2000	4.5-6.5	4.5	2.8	7.7	NO	85.0	96.0	97.5	99.2	1/4 C
2B6-531	6.5	180-2000	4.5-6.5	4.5	2.8	7.7	NO	85.0	96.0	97.5	99.2	1/4 OS
2B6-532	6.5	180-2000	4.5-6.5	4.3	3.4	7.7	YES	85.0	96.0	97.5	99.2	1/4 OS
2B6-535	7.0	300-2200	5.0-7.0	6.3	2.8	9.1	NO	92.0	97.5	98.3	99.3	1/4 OS
2B6-536	7.0	300-2200	5.0-7.0	5.7	3.4	9.1	YES	92.0	97.5	98.3	99.3	1/4 OS
1B7-540	7.7	260-2200	4.0-5.0	3.2	2.0	5.2	NO	83.0	96.1	97.6	99.0	1/4 C
1B7-541	7.7	260-2200	4.0-5.0	3.2	2.0	5.2	NO	83.0	96.1	97.6	99.0	1/4 OS
1B7-542	7.7	260-2200	4.0-5.0	2.9	2.3	5.2	YES	83.0	96.1	97.6	99.0	1/4 OS
2B7-540	8.0	230-2500	6.0-8.0	6.5	2.5	9.0	NO	91.0	97.8	98.7	99.5	1/4 C
2B7-541	8.0	230-2500	6.0-8.0	6.5	2.5	9.0	NO	91.0	97.8	98.7	99.5	1/4 OS
2B7-542	8.0	230-2500	6.0-8.0	5.7	3.3	9.0	YES	91.0	97.8	98.7	99.5	1/4 OS
2B7-545	8.0	230-2500	6.0-8.0	6.5	2.5	9.0	NO	91.0	97.8	98.7	99.5	1/2 C
2B7-546	8.0	230-2500	6.0-8.0	6.5	2.5	9.0	NO	91.0	97.8	98.7	99.5	3/4 C
1B8-550	8.7	320-2900	3.75-4.75	3.3	2.0	5.3	NO	83.0	96.3	97.6	99.0	1/4 C
1B8-552	8.7	320-2900	3.75-4.75	3.3	2.0	5.3	NO	83.0	96.3	97.6	99.0	3/4 C
1B8-553	8.7	320-2900	3.75-4.75	3.3	2.0	5.3	NO	83.0	96.3	97.6	99.0	1/4 OS
1B8-554	8.7	320-2900	3.75-4.75	3.0	2.3	5.3	YES	83.0	96.3	97.6	99.0	1/4 OS
1B8-560	9.4	180-3300	4.0-6.5	4.7	2.0	6.7	NO	85.0	96.6	97.9	99.1	1/4 C
1B8-562	9.4	180-3300	4.0-6.5	4.7	2.0	6.7	NO	85.0	96.6	97.9	99.1	3/4 C
1B8-563	9.4	180-3300	4.0-6.5	4.7	2.0	6.7	NO	85.0	96.6	97.9	99.1	1/4 OS
1B8-564	9.4	180-3300	4.0-6.5	4.4	2.3	6.7	YES	85.0	96.6	97.9	99.1	1/4 OS
2B8-550	8.8	440-2700	7.0-8.0	7.2	2.9	10.1	NO	93.5	97.9	98.8	99.6	1/4 C
2B8-552	8.8	440-2700	7.0-8.0	7.2	2.9	10.1	NO	93.5	97.9	98.8	99.6	3/4 C
2B8-553	8.8	440-2700	7.0-8.0	7.2	2.9	10.1	NO	93.5	97.9	98.8	99.6	1/4 OS
2B8-554	8.8	440-2700	7.0-8.0	6.6	3.5	10.1	YES	93.5	97.9	98.8	99.6	1/4 OS

NOTE: TV = TANK VALVE, OS = OFFSET (FROM CENTER), C = CENTERED, CS = COMBO STUD

SELECTION CHART FOR SUPER-CUSHION® AIR SPRING ISOLATORS

Assembly Number	Max OD @100 PSIG (Inches)	Design Load Range (Pounds)	Design Height Range (inches)	Usable Stroke (Inches)	Min Comp Height (Inches)	Max Ext Height (Inches)	Bumper Included	Approximate Isolation Percent For a Disturbing Frequency Of:				Air Fitting Size (Inches)
								435 CPM	870 CPM	1160 CPM	1750 CPM	
1B9-202	11.0	640-3900	4.5-5.0	3.7	2.2	5.9	NO	84.0	96.6	97.8	99.0	1/4 OS
2B9-200	10.3	340-3700	7.5-9.5	7.6	3.2	10.8	NO	92.0	97.8	98.7	99.5	1/4 OS
2B9-201	10.3	340-3700	7.5-9.5	7.0	3.8	10.8	YES	92.0	97.8	98.7	99.5	1/4 OS
2B9-216	10.3	340-3700	7.5-9.5	7.6	3.2	10.8	NO	92.0	97.8	98.7	99.5	3/4 OS
2B9-250	10.3	540-3800	8.0-10.0	8.7	3.5	12.2	NO	93.3	98.1	99.0	99.5	1/4 OS
2B9-251	10.3	540-3800	8.0-10.0	8.4	3.8	12.2	YES	93.3	98.1	99.0	99.5	1/4 OS
2B9-253	10.3	540-3800	8.0-10.0	8.4	3.8	12.2	YES	93.3	98.1	99.0	99.5	1/4 OS
1B12-313	13.2	1350-8800	3.0-5.0	4.9	2.3	7.2	NO	89.0	97.3	98.4	99.3	1/4 OS
2B12-309	13.0	900-7200	7.5-9.5	6.9	4.2	11.1	YES	92.0	98.0	98.9	99.5	1/4 OS
2B12-425	13.0	900-7200	7.5-9.5	7.7	3.4	11.1	NO	92.0	98.0	98.9	99.5	1/4 OS
2B12-429	13.0	900-7200	7.5-9.5	7.7	3.4	11.1	NO	92.0	98.0	98.9	99.5	3/4 OS
2B12-440	13.7	1300-8100	7.5-9.5	10.6	3.8	14.4	YES	92.5	98.1	99.0	99.5	1/4 OS
3B12-304	12.9	850-7100	11.0-15.0	13.2	4.8	18.0	NO	94.0	98.4	99.1	99.6	1/4 OS
3B12-305	12.9	850-7100	11.0-15.0	13.2	4.8	18.0	NO	94.0	98.4	99.1	99.6	3/4 OS
1B14-350	15.2	1900-11900	4.0-5.25	4.9	2.3	7.2	NO	86.0	96.8	98.0	99.2	1/4 OS
1B14-362	15.9	2250-13,560	3.25-5.25	5.5	2.8	8.3	NO	87.0	97.0	98.1	99.2	3/4 OS
2B14-354	15.1	1500-11100	7.5-9.5	7.6	3.7	11.3	NO	93.0	98.1	99.0	99.5	1/4 OS
2B14-355	15.1	1500-11100	7.5-9.5	6.4	4.9	11.3	YES	93.0	98.1	99.0	99.5	1/4 OS
2B14-362	16.0	2000-13100	7.5-9.5	11.4	4.5	15.2	NO	93.0	98.2	99.0	99.5	1/4 OS
2B14-363	16.0	2000-13100	7.5-9.5	11.4	4.5	15.2	NO	93.0	98.2	99.0	99.5	3/4 OS
2B14-452	16.0	2000-13100	7.5-9.5	11.0	4.2	15.2	YES	93.0	98.2	99.0	99.5	1/4 OS
3B14-354	15.5	1900-12100	10.5-12.5	13.0	5.0	18.0	NO	96.4	99.0	99.4	99.7	1/4 OS
1B15-375	17.5	2200-13700	4.4-5.4	5.6	2.3	7.9	NO	91.0	97.5	98.6	99.4	1/4 OS
2B15-375	16.5	2000-12300	7.5-9.5	9.1	3.7	12.8	NO	93.0	98.2	99.2	99.5	1/4 OS
3B15-375	16.5	2200-12800	10.5-12.5	12.3	4.7	17.0	NO	95.5	98.8	99.3	99.6	1/4 OS
2B19-8433	20.5	3200-23700	7.0-10.0	8.8	3.2	12.0	NO	95.0	98.6	99.1	99.6	-
2B22-8539	23.0	5200-31700	7.0-9.0	9.3	3.2	12.5	NO	96.0	98.8	99.2	99.7	-
1R8-005	8.7	560-3100	10.5-13.0	12.8	5.8	18.6	NO	95.3	98.7	99.2	99.6	1/4 CS
1R8-009	8.7	480-2700	10.5-13.0	11.8	6.8	18.6	YES	96.0	98.9	99.3	99.6	1/4 CS
1R9-009	9.5	800-4400	6.0-7.5	8.6	3.2	11.8	NO	91.0	97.8	98.6	99.4	1/4 CS
1R9-003	9.5	560-3700	8.0-12.0	12.3	5.6	17.9	NO	93.0	98.2	99.0	99.5	1/4 CS
1R10-089	11.0	900-5200	9.5-13.5	14.1	6.0	20.1	NO	96.1	99.0	99.3	99.7	1/4 CS
1R11-028	11.5	1100-6700	6.0-10.0	9.3	3.7	13.0	NO	95.0	98.7	99.2	99.6	1/4 CS
1R11-039	11.3	1300-7000	8.0-12.0	10.9	6.1	17.0	YES	94.0	98.6	99.1	99.5	1/4 CS
1R12-095	12.7	1350-7300	7.0-9.0	9.1	4.4	13.5	YES	94.0	98.4	99.1	99.6	1/4 CS
1R12-132	12.7	1400-7600	8.0-10.0	10.8	6.1	16.9	YES	93.0	98.2	99.0	99.5	1/4 CS
1R12-092	12.7	1350-7600	10.5-16.5	13.4	7.7	21.1	YES	96.0	99.0	99.3	99.7	1/4 CS
1R12-274	12.7	1450-7300	11.3-14.3	14.7	8.1	22.8	YES	96.8	99.1	99.5	99.7	1/4 CS
1R12-103	12.7	1300-7300	15.0-20.0	17.6	9.4	27.0	YES	96.5	99.1	99.4	99.7	1/4 CS
1R12-256	12.7	1350-7300	16.0-20.0	19.6	9.5	29.1	YES	96.3	99.0	99.4	99.7	1/4 CS
1R14-037	14.8	1900-11000	7.5-11.0	12.3	5.7	18.0	YES	92.0	98.0	98.8	99.5	1/4 OS
1R14-018	14.6	1500-8500	11.0-16.5	14.8	7.7	22.5	YES	96.3	99.0	99.4	99.7	1/4 OS
1R14-019	14.6	1500-8500	14.0-18.0	16.9	8.9	25.8	YES	96.7	99.1	99.5	99.7	1/4 OS

NOTE: TV = TANK VALVE, OS = OFFSET (FROM CENTER), C = CENTERED, CS = COMBO STUD

The GOODYEAR (and Winged Foot Design) trademark is used by Veyance Technologies, Inc. under license from The Goodyear Tire & Rubber Company. Goodyear Engineered Products are manufactured and sourced exclusively by Veyance Technologies, Inc. or its affiliates. The following trademarks are licensed to Veyance Technologies, Inc. by The Goodyear Tire & Rubber Company, including Compass, Eagle Pd, Flexten, Gatorback and GY Metric. ©2008 Veyance Technologies, Inc. All Rights Reserved.



AUXILIARY EQUIPMENT

1. PNEUMATIC CONTROL SYSTEMS -

A. Height Control Systems

Height control systems are commonly used to automatically control the dimension between the axle and the frame of a vehicle.

Most units incorporate a time delay of 3-20 seconds. With the time delay, the suspension system operates effectively as a closed system-except during an event causing height variations which lasts longer than the time delay period. Such events may include long curves, adding or removing load, or stopping on uneven terrain.

There are two common ways of piping vehicle height control systems. One method is to mount one height control valve on each side of the vehicle. Here, all the air springs on each side of the vehicle are connected together and are controlled by the valve on that side of the vehicle. However, the height control valve must be located so that it can effectively control the vehicle height at all axles in the system. This two valve arrangement is more common on trailers.

Another method of connection uses only one valve and all the air springs on the vehicle are connected together. The single-valve system allows gas to be transferred from the air spring on one side of the vehicle to the air springs on the other side of the vehicle with roll. This air transfer may be a disadvantage. With the single-valve system, the roll rate of the vehicle is very dependent upon components of the suspension other than the air springs. With the two valve system, side-to-side pressure differences help provide roll stability.

One of the important benefits of air suspensions is realized by connecting all of the air springs on a given side of a multi-axle vehicle together. Such interconnecting provides excellent equalization of load from axle to axle under static conditions when the air springs used are rolling lobes with very "straight wall" pistons and all axles use the same configuration suspensions. The accuracy of equalization obtained with air spring type units is very difficult to obtain with other types of suspensions.

With this type of plumbing, another benefit of pneumatic suspensions is realized under dynamic conditions. Under dynamic conditions, each axle is in effect independently suspended. The axles act independently because the interconnecting gas lines are generally small and the time duration of the dynamic input is short, which does not allow gas transfer and equalization to occur as in the static condition.

When a vehicle is completely pneumatically suspended, one of the axles-usually the steering axle-must have a single height control valve and two valves are used on another axle. This provides 3 point levelling. If four valves are used, terrain or structural variations will cause three of the air springs to support the vehicle. Such a condition will result in one of the air springs being deflated much of the time. Four valve systems are not recommended.

B. Manual Pressure Control Systems

With manual pressure control systems, the load on a particular axle is controlled. The effective area of the air spring, multiplied by the gas pressure applied to that spring, is proportional to the load on the axle. Pressure control systems are used where the pneumatic suspensions are used in conjunction with other types of suspensions.

The load on an added non-driving axle on tractors or trucks is usually controlled by a pressure-type control system. Specifically, the most common system used to control the load on the non-driving added axle of a tractor is an operator-controlled, cab-mounted pressure regulator. The driver sets the pressure regulator to a pressure as indicated on a gauge in the cab of the vehicle to obtain the desired axle loading. This control system accommodates frame height variations caused by deflection of the associated mechanical spring suspension unit. In plumbing this system, both air springs are connected together and their pressure is controlled by the same regulator. This interconnection of air springs is not a major disadvantage in this type of application, since the roll stability requirement for the vehicle is substantially determined by the mechanical suspensions used in conjunction with the pneumatic suspension.

Another system incorporates two or more preset regulators which are selected by a multi-position switch. This system is very useful when the loads carried are predetermined and repeated. A variation of this circuit incorporates a regulator which proportions load from one side of the vehicle to the other. This system is used, for example, on cement mixers. One side of the vehicle is more heavily loaded than the other when the barrel is rotating.

C. Pneumatic Switch (On/Off) Type Control Systems

Pneumatic on/off switches have many uses with pneumatic suspensions. The most common application is in the lifting of one axle of a vehicle. The switch is used to control the axle lift-that is, adding gas to the pneumatic lift spring and exhausting gas from the suspension air springs. Another use is raising and lowering the vehicle to provide a desired height. One switch on each side of the vehicle can be used to roll the vehicle from side to side. Switches controlling the gas pressure in the front and rear air springs of a vehicle will permit tipping the vehicle toward the front or rear. On/off switches can be operated by other than mechanical means. Pneumatically or electrically actuated switches are used in many of the systems described.

D. Load Measurement Systems

Approximate load measurement can be accomplished with air suspension systems. Some of the considerations in their use will be described here. Rolling sleeve springs provide a more constant effective area over a greater range of design heights than do convolution springs. Scaling systems are, therefore, more accurate when used with rolling sleeve springs. The unsprung mass of a suspension and axis must be considered in load-measuring systems. This is usually done by calibrating the load-measuring system on a legal weight scale after installation. Other variables, which may affect the accuracy of the scaling device, are suspension geometry and pinion angle variations.

There are three basic types of load-measuring systems. One system incorporates simply a pressure gauge attached to the air spring on each side of the vehicle. To read this system the operator must read each of the gauges, multiply by the appropriate factor for the suspension involved, and add that reading to a similar measurement from the opposite side of the vehicle. Through these calculations, the operator can obtain the load on the unit.

A refined system incorporates a valve with two reservoirs. This system samples the gas pressure from each side of the vehicle, averages the two pressures together, and displays the results on a gauge calibrated to read load. Once calibrated, this type of system is operated merely by pushing a button which actuates the valve.

A third system incorporates valves which when actuated connect all of the air springs on the vehicle together. When the pressure equalizes, it is read and multiplied by the appropriate factor for the suspensions involved.

The use of scaling devices with pneumatic suspensions allows the operator to load the maximum amount of cargo without incurring the risk of overload during a drive from the loading site to a scale.

E. Modulated Brake Systems

Valves are available which allow proportioning of braking effort to load on pneumatically suspended axles. The proportioning is accomplished by modulating the gas pressure available to the braking system. The modulation is controlled by the pressure in the air suspension system which is proportional to the load on that system.

F. Automated Multifunction Control Systems

Automatic pneumatic controls can be incorporated to prevent the sudden rise of the rear of a tractor when it is being disconnected from a loaded trailer. These same systems usually prevent the air spring from folding in by maintaining equal pressure in all of the air springs when the vehicle is operated in a light condition. Actuation of the axle lift on trailer units or on the non-driving axle of a pneumatically suspended dead axle

drive axle tandem can be accomplished automatically, as can load proportioning from axle to axle (which is desirable on certain vehicle combinations). The dumping of gas from the system automatically under certain conditions of vehicle usage is another system which can be incorporated. Many of these systems are triggered by a signal received when the trailer gas supply hose is disconnected or when the fifth-wheel latch is actuated.

Preventing the sudden rise of the rear of the tractor when it is being disconnected from a loaded trailer is accomplished by discharging the gas pressure in the system required to support the loaded trailer through a quick release type valve. After the high pressure required to support the loaded trailer is discharged, a regulated low-pressure circuit is actuated. This circuit provides a regulated pressure through the height control valves only high enough to allow suspension of the vehicle by the air springs once the unit is disconnected from the loaded trailer. This low-pressure circuit prevents resupply of the air springs with the high pressure required to support the loaded trailer and, thus, the jumping which occurs without such a system.

On units with a height control valve on each side of the vehicle, it is often extremely difficult to maintain proper air spring inflation when the vehicle is not loaded. By switching automatically to a single valve system when the vehicle is unloaded, the problems associated with uninflated pneumatic springs are avoided.

One of the most sophisticated automatic systems currently available is used on a tractor having a pneumatically suspended non-driving added axle and a drive axle on pneumatic suspensions. The non-driving axle remains in a retracted position until the load on the drive axle reaches a predetermined load level. The non-driving axle is automatically lowered at the preset load level and any additional load above the preset level is applied to the non-powered axle. When the load on both axles reaches a second preset level, any additional load is applied equally to each axle of the tandem. As load is removed from the vehicle, the load on the non-driving axle decreases first. When the load on the combination of the non-driving and driving axle decreases to a predetermined amount which can be supported on the driving axle, the non-driving axle is automatically lifted. This system is completely automatic and requires no operator control.

A manually operated overriding system is often provided on units with automatic pneumatic control systems to allow a load to be transferred from a non-driving to a driving axle. Load transfer can be used to provide increased tractive effort when needed. Most traction control systems automatically revert to the original load proportions when the operator releases the actuating control.

2. COMPRESSION CONTROL DEVICES

The low spring rates obtained with air springs may permit very large amounts of axle travel without the buildup of sufficient force to prevent the axle from reaching its limit of travel. To avoid the abrupt "bottoming out" at the end of jounce travel, air springs often contain compression bumpers. Separate external stops are also sometimes used. Internal stops are usually made of rubber with a tailored compression rate featuring a soft entry and rapid buildup in load capacity. These compression bumpers are customarily sized to carry a load exceeding the pneumatic spring capacity without damage to the bumper. More rigid external stops are often positioned so that their effect is utilized only after some compression of the internal stop has occurred. External stops contacting the axle directly are used to prevent excessive loads on the suspension systems. The internal stops, in the event of loss of pressure in this suspension system, allow the vehicle to be driven to a service area without damage to the air springs or other components.

3. EXTENSION CONTROL DEVICES

A pneumatic spring is usually intended to carry a load in only a compressive direction and may be damaged by extending it beyond its normal fully extended position. Because of this characteristic, some means of controlling the motion of the axle in the rebound mode is required. The amount of axle travel in the rebound mode must be controlled by some component of the suspension other than the air spring. This function is most often accomplished by the use of hydraulic shock absorbers. Other mechanical linkages such as chains, cables, or links are also used.

4. ROLL CONTROL SYSTEMS

The low spring rates inherent with air springs, combined with a narrow spring base of trucks and buses with dual tires, impose the requirement for control of vehicle roll on corners and crowded roadways with some auxiliary device or system. Three types of systems can be used.

A. Roll control can be provided by mechanical, anti-roll stabilizing linkages which are independent or which are integral parts of the major suspension system. In automotive systems, this is usually accomplished by an auxiliary bar loaded torsionally. On large highway truck, tractor, and trailer applications, this function is performed as an integral part of the mechanical characteristics of the suspension system.

B. A hydraulic system incorporating two double-acting cylinders with interconnecting lines between the top of a cylinder on one side and the bottom of a cylinder on the opposite side, with their stems connected to the suspension or axle, can be used to prevent or control roll.

C. A third method would be to control the gas pressure in each of the springs with a pneumatic control system with response fast enough to react to roll mode inputs. This, in effect, would be very fast-acting height control valve system. It would have to be much faster than currently used systems.

5. GAS SUPPLY SYSTEMS

Engine-operated piston-type compressors are the principal method of obtaining compressed gas for use in vehicle pneumatic suspension systems. For vehicles which do not have engine driven gas compressors available, electrically operated 12V gas compressors are available. Reliable units providing pressures of 90 PSIG (or greater) similar to that provided by engine-driven compressor units are available. These units will supply sufficient gas to accommodate most pneumatic suspension systems. Vacuum-powered units are also available. These units generally supply gas only at very low pressures and in small quantities.

Vehicle pneumatic suspension systems, like all auxiliary pneumatic systems, are required by law to be isolated from the brake system. The isolation is usually accomplished by a valve called a brake protection valve which maintains a preset gauge pressure, usually 65 PSIG in the brake system. The brake protection valve is installed at the connection of the suspension system to the main supply system.

The GOODYEAR (and Winged Foot Design) trademark is used by Veyance Technologies, Inc. under license from The Goodyear Tire & Rubber Company. Goodyear Engineered Products are manufactured and sourced exclusively by Veyance Technologies, Inc. or its affiliates. The following trademarks are licensed to Veyance Technologies, Inc. by The Goodyear Tire & Rubber Company, including Compass, Eagle Pd, Flexten, Gatorback and GY Metric. ©2008 Veyance Technologies, Inc. All Rights Reserved.



INTERPRETATION OF THE ENGINEERING DATA

The Left Hand Page

1. Top, side and bottom views of the air spring assembly appear on the left side of this page.
2. In the top right of this page appears a list of all assemblies constructed with the flexible member shown in the product drawing. These springs may differ by air fitting size, or whether or not a bumper is included as part of the assembly.
3. The Spring Features table lists the important characteristics of the Super-Cushion air spring assembly.
4. The Other Options section shows variations from the assemblies listed above that are available by special request. Some springs may not have other options available.
5. The Recommended Max. Torque Values table lists the maximum torque that should be applied to the air spring components shown.

The Right Hand Page

1. Load vs. Deflection @ Constant Pressure Graph. This graph shows load vs. deflection curves at 20, 40, 60, etc. PSIG. (See Understanding the Graphs, below.)
2. Constant Pressure Characteristics. This table provides the meniscus height, (M) (for rolling lobe and sleeve type air springs), volume and force available at various spring heights. Force available information is given for pressures ranging from 20 to 100 PSIG. The recommended design height range is highlighted for ease of selection for vibration isolation.
3. Dynamic Load vs. Deflection Graph. These curves provide load and pressure information for the spring, tested at one specific design height. (See Understanding the Graphs, below.)
4. Dynamic Characteristics. This table provides pressure, spring rate (vertical) and natural frequency information for the spring over a wide load range at three different design heights.

UNDERSTANDING THE GRAPHS

1. Load vs. Deflection @ Constant Pressure Graph

Constant pressure data is available at loads of 20, 40, 60 etc., PSIG. This pressure is maintained over the entire stroke of the air spring (from compressed height to maximum extended height), except in certain cases where at higher pressures the curve is truncated before reaching maximum extended height. In other words, to maintain constant pressure, air is exhausted as the spring compresses and air is added as the spring extends.

To read this graph, find the height at which the spring will be operating and follow a straight line up to the curve for the desired pressure; mark this intersection point. The load carrying capability is then found by drawing a horizontal line from this intersection point to the load axis (left axis). Read the load at this intersection point. The Constant Pressure Characteristics Table below this graph provides the same information at a number of spring heights.

2. Dynamic Load vs. Deflection Graph

The dynamic curves show five different loads tested at one design height (highlighted). The load is set at the design height, and the air pressure is locked in. The spring is then actuated through its entire stroke (from compressed height to maximum extended height) except in those cases where the pressure exceeds 250 PSIG. If this happens, the compression of the spring is reduced. Given an initial load at a locked in corresponding pressure, the graph allows the designer to see how that load and pressure change as the spring travels throughout its stroke.

The load vs. deflection curves are the bottom set of curves, and are read using the load axis (left axis). The pressure vs. deflection curves are the top set of curves, and are read using the Pressure axis (right axis). The load and pressure curves do correspond, i.e. L_1 matches with P_1 , L_2 matches with P_2 , etc. The Dynamic Characteristics Table provided below this graph shows dynamic characteristics at three design heights (bottom, middle and top of the Design Height Range). **The graph corresponds only to the middle design height.**



1B5-500

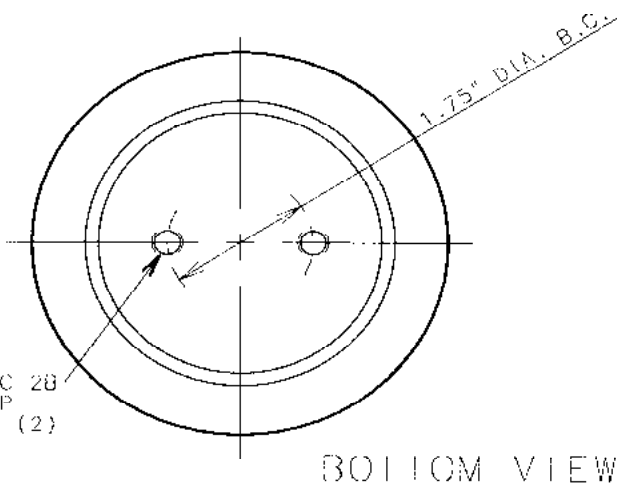
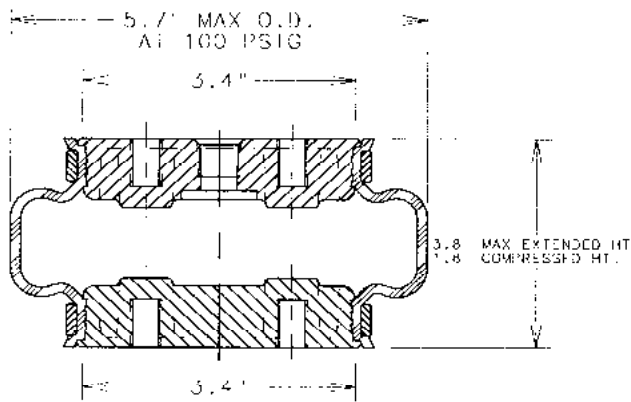
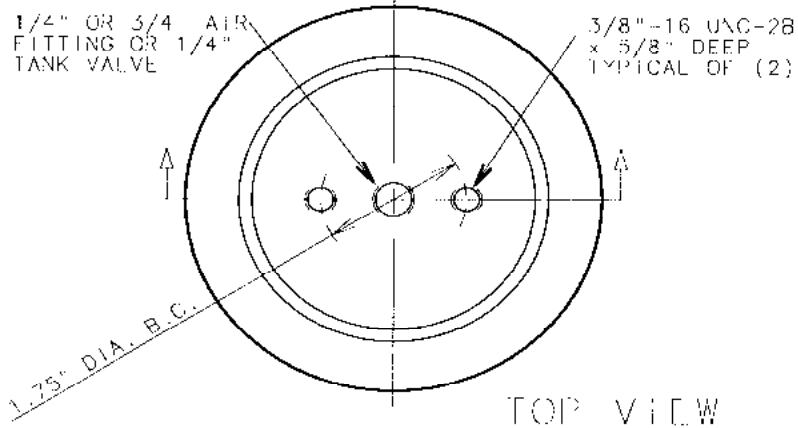

ASSEMBLY NUMBER	ELASTOMER	AIR FITTING	BUMPER INCLUDED
1B5-500	WINGPRENE®	1/4"-18 NPTF	NO
1B5-502	WINGPRENE®	3/4"-14 NPTF	NO
1B5-503	WINGPRENE®	1/4"-18 NPTF W/TANK VALVE INSTALLED	NO

SPRING FEATURES:

- LOAD RANGE (ISOLATOR).....210-1350 lb
- DESIGN HEIGHT RANGE (ISOLATOR).....2.5-3.0 in
- USEABLE STROKE (ACTUATOR).....2.0 in
- ASSEMBLY WEIGHT.....1.7 lb
- FORCE TO COMPRESS AT 0 PSIG (APPROX.).....9 lb
- NOMINAL FREE STANDING HT. AT 0 PSIG.....2.5 in

OTHER OPTIONS:

- SHOULDER STUD 3/8"-16 UNC 3A x 9/16" BY 1/2"-13 UNC-3A x 2-1/2" (578-92-9 G56)

RECOMMENDED MAX. TORQUE VALUES

1/8"-18 UNC BLIND TAP TYP. OF (4)	1/4"-18 UNC AIR FITTING	3/4"-14 UNC AIR FITTING
240 in lb 28 ft-lb	240 in lb 20 ft-lb	240 in lb 20 ft-lb

NOTE: SEE GUIDELINES FOR PROPER APPLICATION OF THIS PRODUCT

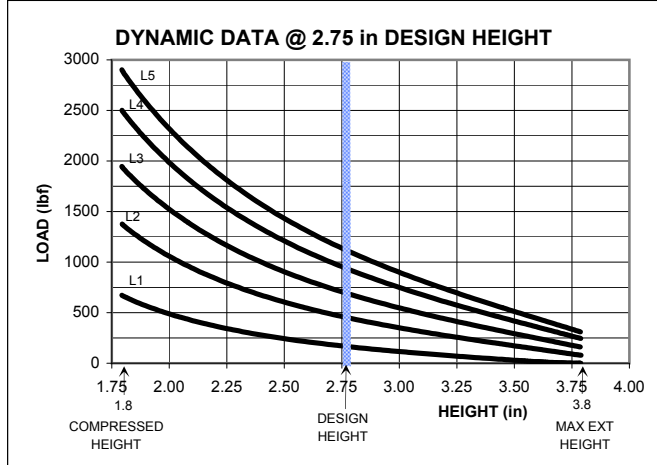
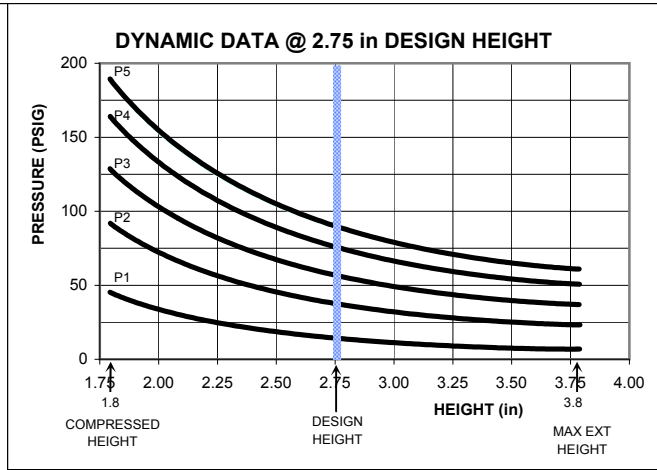
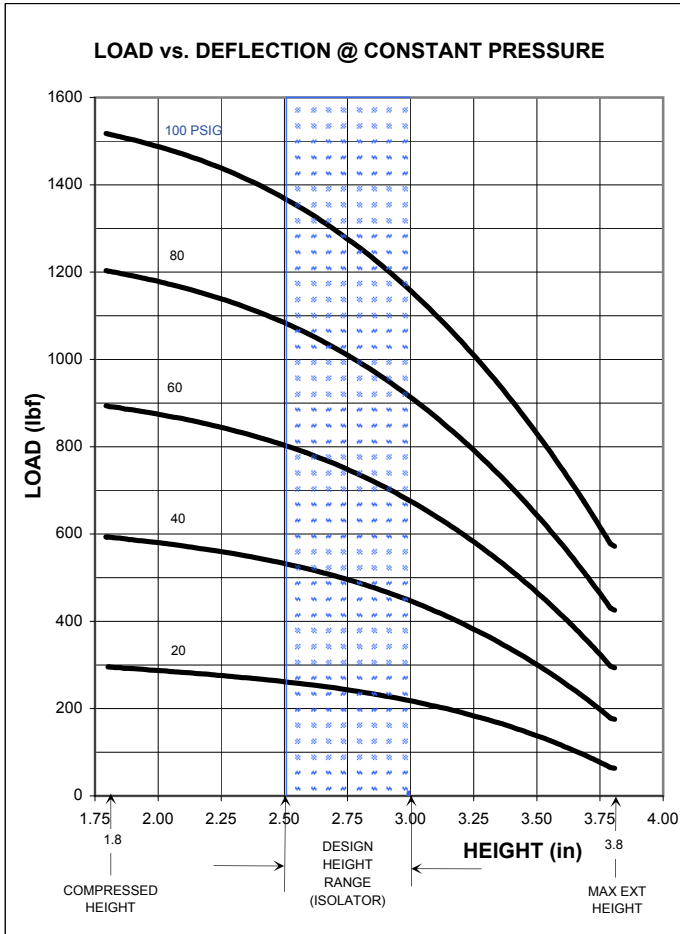

****NOTE: MAXIMUM INFLATION PRESSURE IS 100 PSIG. MAXIMUM JOUNCE PRESSURE IS 200 PSIG. IF YOUR APPLICATION WILL EXCEED THESE LIMITS, CONSULT A GOODYEAR ENGINEERED PRODUCTS AIR SPRINGS REPRESENTATIVE FOR APPLICATION ASSISTANCE.**

CONSTANT PRESSURE CHARACTERISTICS

Assembly Height (in)	Volume @ 100 PSIG (in ³)	Nominal Force (lb)				
		@ 20 PSIG	@ 40 PSIG	@ 60 PSIG	@ 80 PSIG	@ 100 PSIG
		3.8	51	60	170	280
3.5	48	130	280	440	620	800
3.0	41	210	420	660	850	1100
2.75	37	240	480	700	1000	1250
2.5	33	260	520	800	1050	1350
2.0	26	280	560	850	1150	1450
1.8	24	280	580	900	1200	1500

DYNAMIC CHARACTERISTICS

Design Height (in)	Load (lb)	Pressure (PSIG)	Spring Rate (lb/in)	Natural Frequency	
				cpm	Hz
3.0	200	18	275	223	3.72
	500	44	545	195	3.25
	750	64	750	188	3.13
	950	86	970	184	3.07
2.75	1150	100	1130	182	3.03
	200	16	275	220	3.67
	500	41	535	193	3.22
	750	60	745	186	3.10
2.5	950	80	950	182	3.03
	1150	94	1095	180	3.00
	200	15	295	228	3.80
	500	37	550	198	3.30
2.0	750	55	765	190	3.17
	950	74	975	185	3.08
	1150	89	1140	182	3.03

The GOODYEAR (and Winged Foot Design) trademark is used by Veyance Technologies, Inc. under license from The Goodyear Tire & Rubber Company. Goodyear Engineered Products are manufactured and sourced exclusively by Veyance Technologies, Inc. or its affiliates. The following trademarks are licensed to Veyance Technologies, Inc. by The Goodyear Tire & Rubber Company, including Compass, Eagle Pd, Flexten, Gatorback and GY Metric. ©2008 Veyance Technologies, Inc. All Rights Reserved.



1B5-510

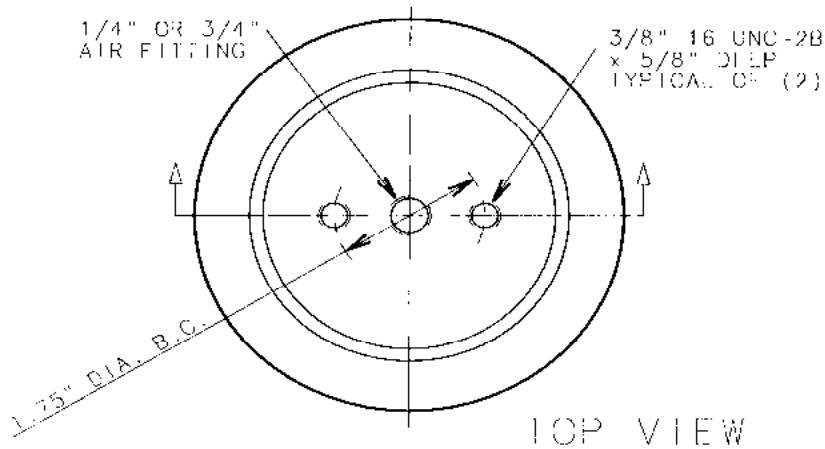

TOP VIEW

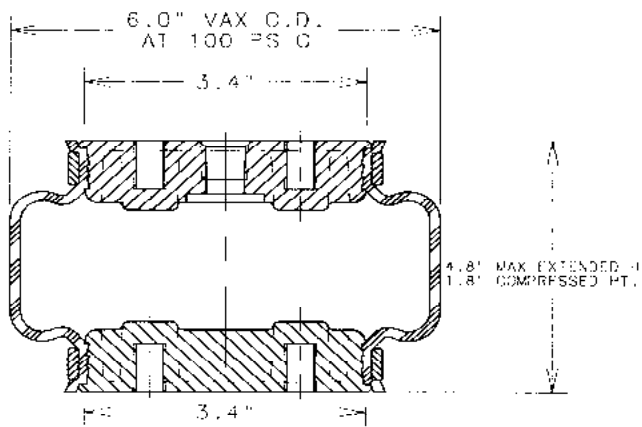

SIDE VIEW

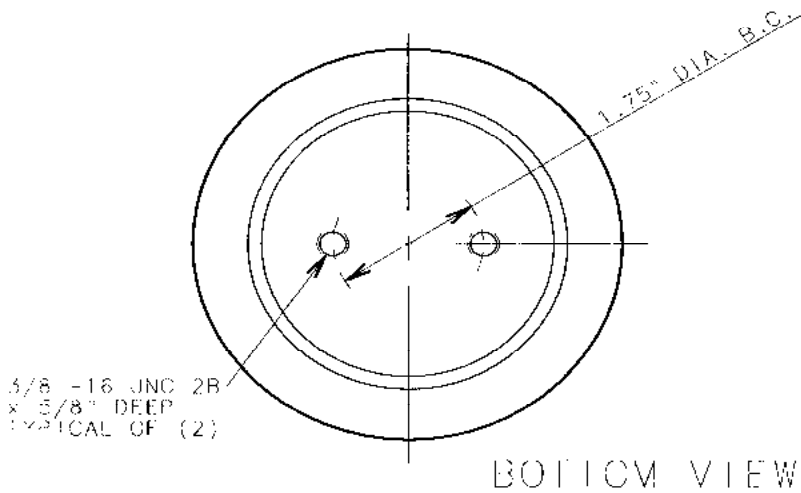

BOTTOM VIEW

ASSEMBLY NUMBER	ELASTOMER	AIR FITTING	BUMPER INCLUDED
1B5 510	WINOPRENE®	1/4" 16 NPTF	NO
1D5 512	WINOPRENE®	3/4"-14 NPTF	NO

SPRING FEATURES:

- LOAD RANGE (ISOLATOR).....190-1500 lb
- DESIGN HEIGHT RANGE (ISOLATOR).....2.5-4.0 in
- USEABLE STROKE (ACTUATOR).....3.0 in
- ASSEMBLY WEIGHT1.2 lb

OTHER OPTIONS:

- SHOULDER STUD 3/8"-16 UNC-3A x 9/16" BY 1/2"-13 UNC-3A x 2 1/2" (578 92-9-356)

RECOMMENDED MAX. TORQUE VALUES

3/8"-16 UNC BLIND TAP 1 1/2" OF (4)	1/4"-16 UNC AIR FITTING	3/4"-14 UNC AIR FITTING
240 in-lb 20 ft-lb	240 in-lb 20 ft-lb	240 in-lb 20 ft-lb

NOTE: SEE GUIDELINES FOR PROPER APPLICATION OF THIS PRODUCT

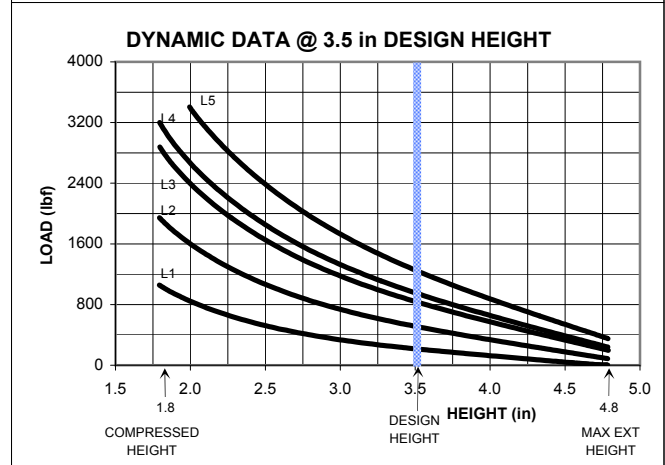
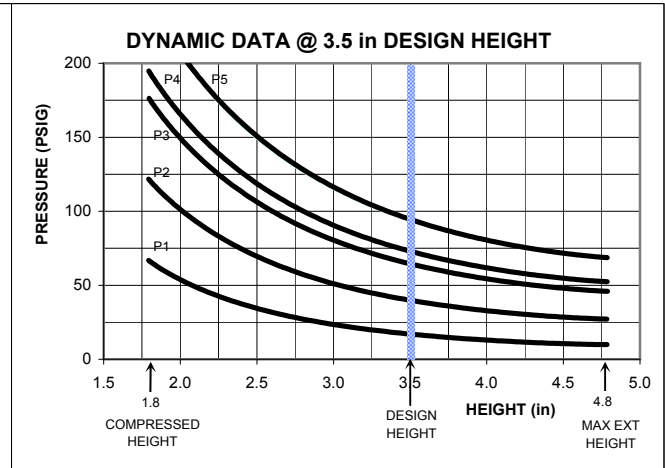
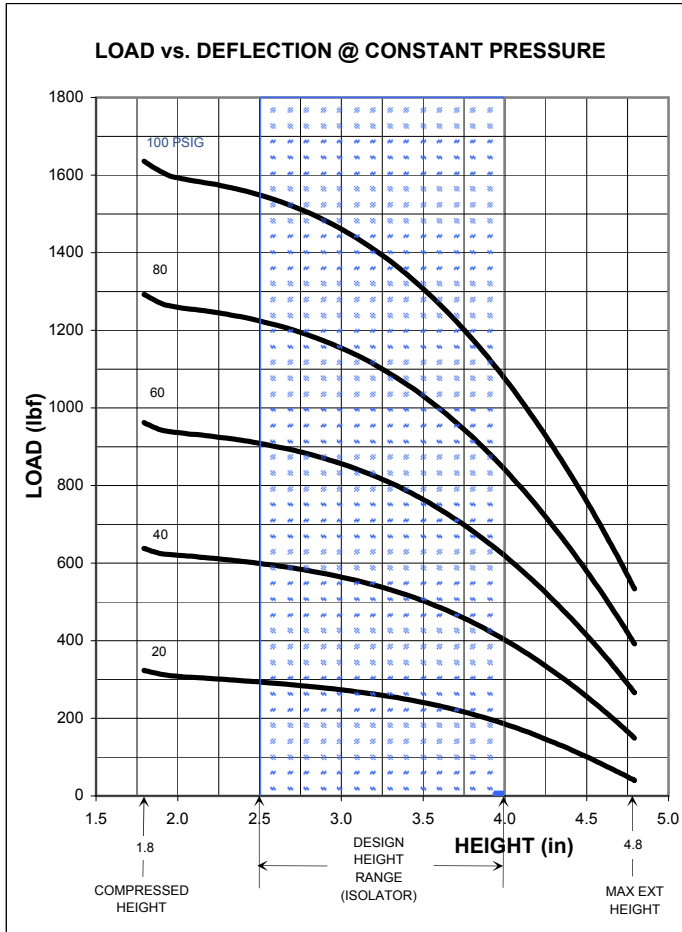

****NOTE: MAXIMUM INFLATION PRESSURE IS 100 PSIG. MAXIMUM JOUNCE PRESSURE IS 200 PSIG. IF YOUR APPLICATION WILL EXCEED THESE LIMITS, CONSULT A GOODYEAR ENGINEERED PRODUCTS AIR SPRINGS REPRESENTATIVE FOR APPLICATION ASSISTANCE.**

CONSTANT PRESSURE CHARACTERISTICS

Assembly Height (in)	Volume @ 100 PSIG (in ³)	Nominal Force (lb)				
		@ 20 PSIG	@ 40 PSIG	@ 60 PSIG	@ 80 PSIG	@ 100 PSIG
4.8	68	30	140	260	380	520
4.5	64	110	260	420	580	700
4.0	59	190	400	620	850	1050
3.5	52	250	500	750	1000	1250
3.0	45	280	560	850	1150	1450
2.5	37	300	600	900	1200	1500
2.0	30	300	620	900	1250	1600
1.8	25	320	620	950	1250	1600

DYNAMIC CHARACTERISTICS

Design Height (in)	Load (lb)	Pressure (PSIG)	Spring Rate (lb/in)	Natural Frequency	
				cpm	Hz
4.0	250	24	265	194	3.23
	550	52	495	177	2.95
	850	80	715	170	2.83
	950	91	805	169	2.82
3.5	250	19	220	177	2.95
	550	42	415	163	2.72
	850	68	625	158	2.63
	950	76	695	156	2.60
	1250	98	865	153	2.55
2.5	250	16	275	199	3.32
	550	36	470	174	2.90
	850	57	670	165	2.75
	950	65	750	162	2.70
	1250	84	930	159	2.65

The GOODYEAR (and Winged Foot Design) trademark is used by Veyance Technologies, Inc. under license from The Goodyear Tire & Rubber Company. Goodyear Engineered Products are manufactured and sourced exclusively by Veyance Technologies, Inc. or its affiliates. The following trademarks are licensed to Veyance Technologies, Inc. by The Goodyear Tire & Rubber Company, including Compass, Eagle Pd, Flexten, Gatorback and GY Metric. ©2008 Veyance Technologies, Inc. All Rights Reserved.



1B5-520

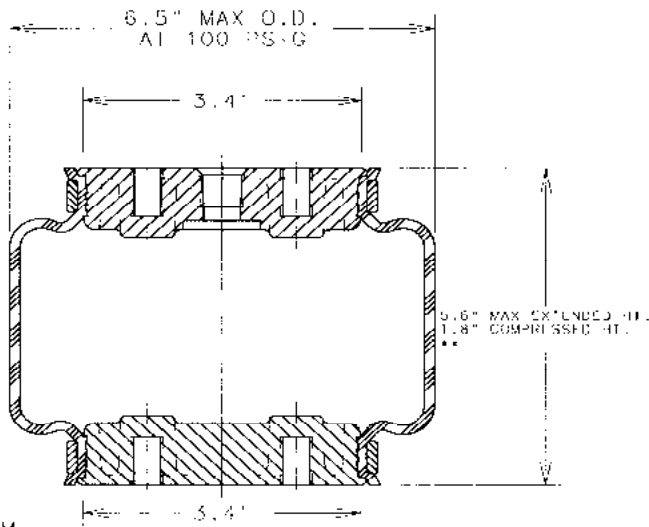
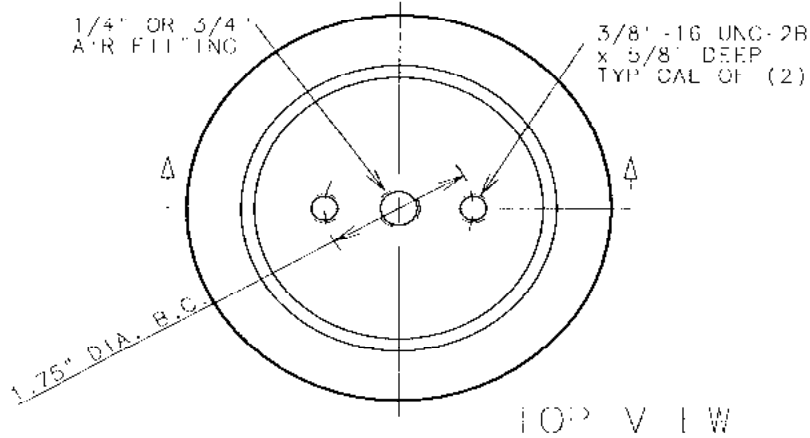

TOP AND BOTTOM SURFACE TO BE FULLY SUPPORTED BY 6.75" DIA. PLATE OR SHI INSTALLATION GUIDELINES SECTION FOR ALTERNATE MOUNTING OPTIONS

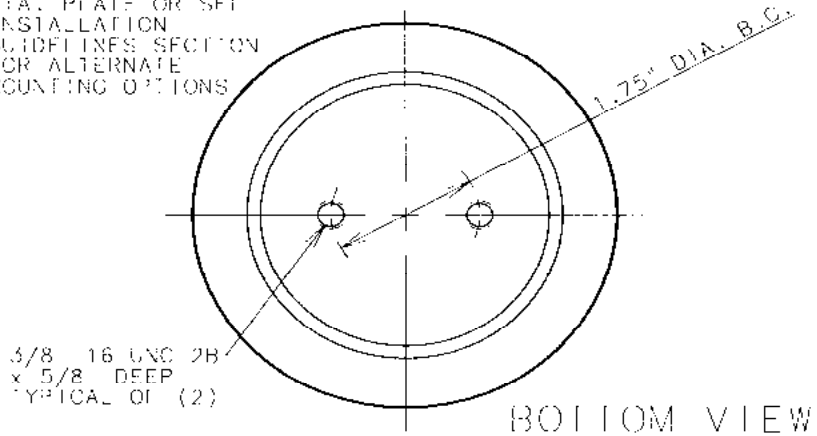

ASSEMBLY NUMBER	ELASTOMER	AIR FITTING	DJWPER INCL. USED
1B5-520	W NBRPNE [®]	1/4" -18 NPT [†]	NO
1B5-521	W NBRPNE [®]	3/4" -14 NPT [†]	NO

** NOTE: AS ACTUATOR-DO NOT USE BELOW 2.8" HEIGHT-SEE INSTALLATION GUIDE LINES.

SPRING FEATURES:

- LOAD RANGE (ISOLATOR).....190-1500 lb
- DESIGN HEIGHT RANGE (ISOLATOR).....3.5-5.0 in
- USEABLE STROKE (ACTUATOR).....3.0 in
- ASSEMBLY WEIGHT.....1.4 lb
- FORCE TO COMPRESS AT 0 PSIG (APPROX.).....40 lb
- NOMINAL FREE STANDING HT. AT 0 PSIG.....4.3 in

OTHER OPTIONS:

- SHOULDER STUD 3/8" -16 UNC-3A x 9/16" BY 1/2" -13 UNC 3A x 2-1/2" (5/8 92 9 056)

RECOMMENDED MAX. TORQUE VALUES

3/8"-16 UNC BLIND TAP TYP. OF (4)	1/4"-18 UNC AIR FITTING
240 in-lb 20 ft-lb	240 in-lb 20 ft-lb

NOTE: SEE GUIDELINES FOR PROPER APPLICATION OF THIS PRODUCT

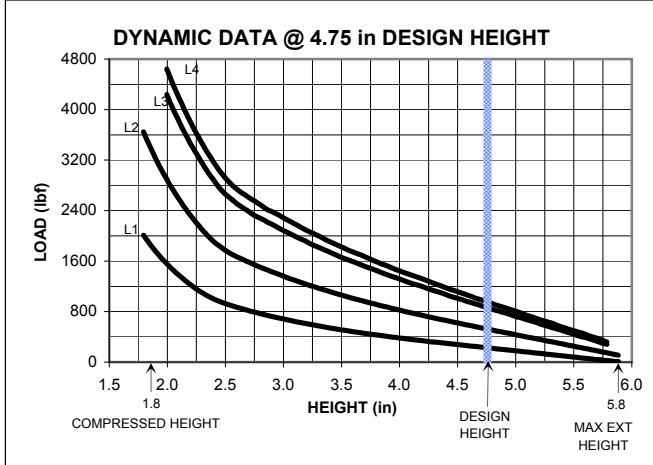
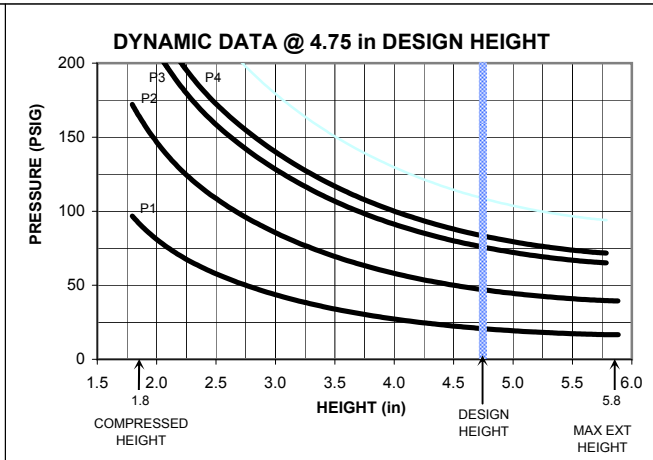
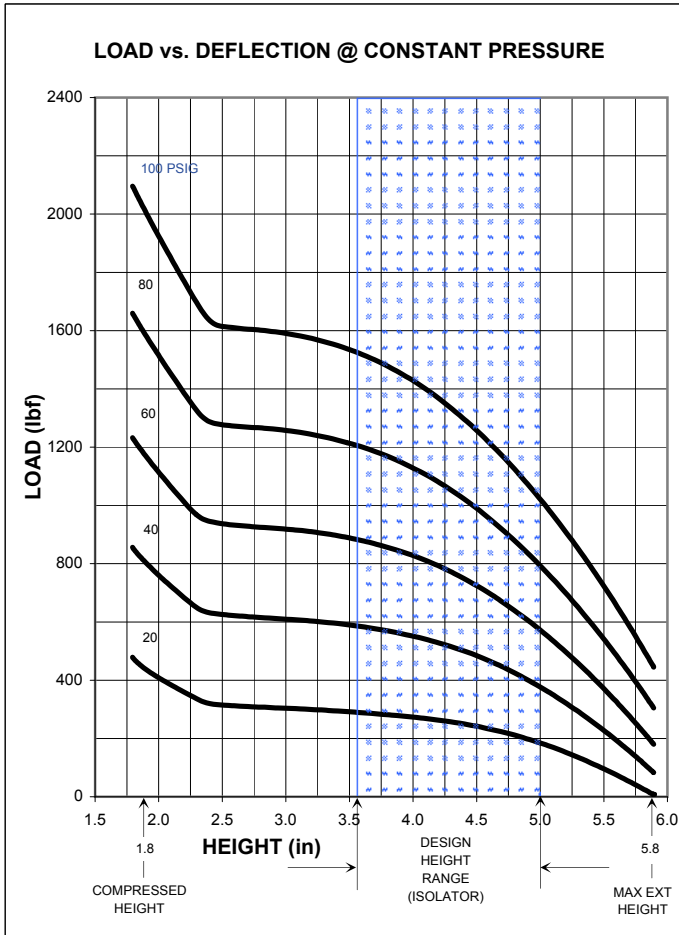

****NOTE: MAXIMUM INFLATION PRESSURE IS 100 PSIG. MAXIMUM JOUNCE PRESSURE IS 200 PSIG. IF YOUR APPLICATION WILL EXCEED THESE LIMITS, CONSULT A GOODYEAR ENGINEERED PRODUCTS AIR SPRINGS REPRESENTATIVE FOR APPLICATION ASSISTANCE.**

CONSTANT PRESSURE CHARACTERISTICS

Assembly Height (in)	Volume @ 100 PSIG (in ³)	Nominal Force (lb)				
		@ 20 PSIG	@ 40 PSIG	@ 60 PSIG	@ 80 PSIG	@ 100 PSIG
5.8	93	0	80	180	300	440
5.5	89	100	230	380	540	700
5.0	84	190	380	580	800	1000
4.75	80	220	440	660	900	1150
4.0	70	280	560	800	1100	1450
3.5	63	280	600	900	1200	1500
3.0	55	300	620	900	1250	1600
2.5	46	320	620	950	1250	1600
2.0	36	420	750	1100	1500	1900
1.8	31	480	850	1200	1600	2100

DYNAMIC CHARACTERISTICS

Design Height (in)	Load (lb)	Pressure (PSIG)	Spring Rate (lb/in)	Natural Frequency	
				cpm	Hz
5.0	250	24	235	182	3.03
	550	53	430	166	2.77
	900	83	630	159	2.65
	1000	93	700	157	2.62
4.75	250	22	210	171	2.85
	550	49	395	158	2.63
	900	76	575	151	2.52
	1000	85	635	150	2.50
3.5	250	16	185	159	2.65
	550	36	305	140	2.33
	900	57	450	134	2.23
	1000	65	500	133	2.22
	1250	83	630	131	2.18

NOTE: AS AN ACTUATOR, DO NOT USE BELOW 2.8" HEIGHT -- SEE INSTALLATION GUIDELINES FOR DETAILS.

The GOODYEAR (and Winged Foot Design) trademark is used by Veyance Technologies, Inc. under license from The Goodyear Tire & Rubber Company. Goodyear Engineered Products are manufactured and sourced exclusively by Veyance Technologies, Inc. or its affiliates. The following trademarks are licensed to Veyance Technologies, Inc. by The Goodyear Tire & Rubber Company, including Compass, Eagle Pd, Flexten, Gatorback and GY Metric. ©2008 Veyance Technologies, Inc. All Rights Reserved.



1B6-530

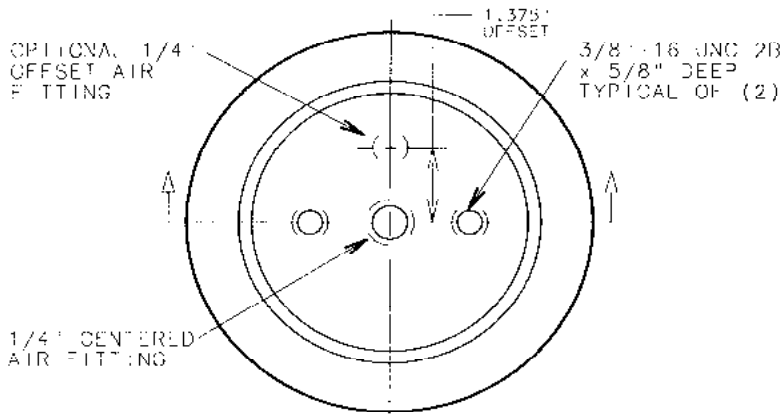

TOP VIEW

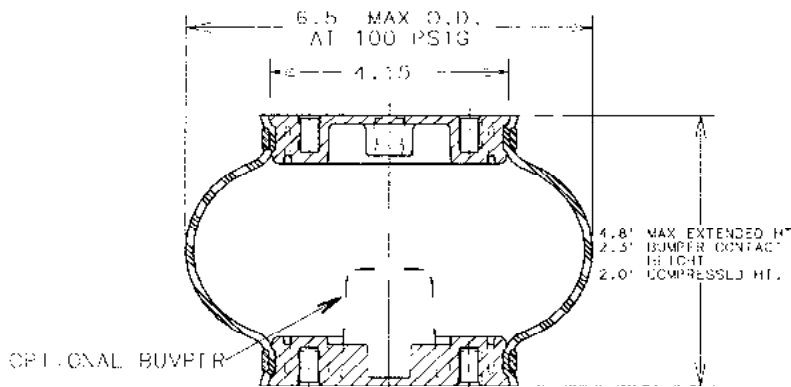

1.75" B.C. FOR 1B6-530
2.75" B.C. FOR 1B6-531 AND 1B6-532

SIDE VIEW

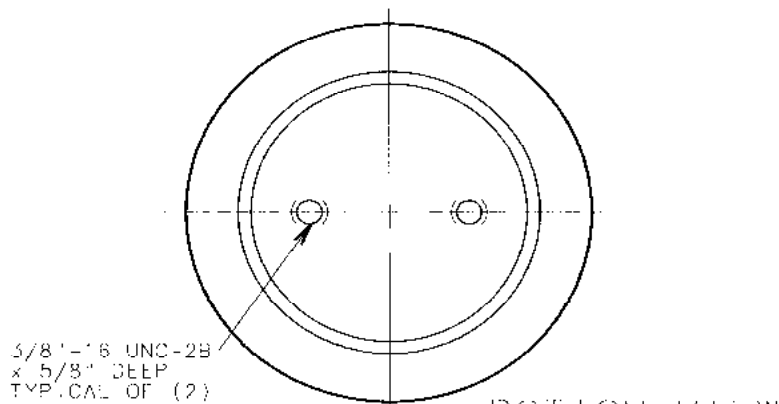

BOTTOM VIEW

ASSEMBLY NUMBER	ELASTOMER	AIR FITTING	BUMPER INCLUDED
1B6-530	WINGOPRENE®	1/4"-18 NPTF CENTERED	NO
1B6-531	WINGOPRENE®	1/4"-18 NPTF OFFSET 1.375	NO
1B6-532	WINGOPRENE®	1/4"-18 NPTF OFFSET 1.375	YES

SPRING FEATURES:

- LOAD RANGE (ISOLATOR).....280-1900 lb
- DESIGN HEIGHT RANGE (ISOLATOR).....3.0-4.0 in
- USEABLE STROKE w/o BUMPER (ACTUATOR)....2.8 in
- USEABLE STROKE WITH BUMPER (ACTUATOR)....2.5 in
- ASSEMBLY WEIGHT w/o BUMPER.....3.3 lb
- FORCE TO COMPRESS AT 0 PSIG (APPROX.)....25 lb
- NOMINAL FREE STANDING HT. AT 0 PSIG.....3.9 in

RECOMMENDED MAX. TORQUE VALUES

3/8"-16 UNC BLIND TAP TYP. OF (4)	1/4"-18 UNC AIR FITTING
240 in-lb 20 ft-lb	240 in-lb 20 ft-lb

NOTE: SEE GOODYEAR'S FOR PROPER APPLICATION OF THIS PRODUCT

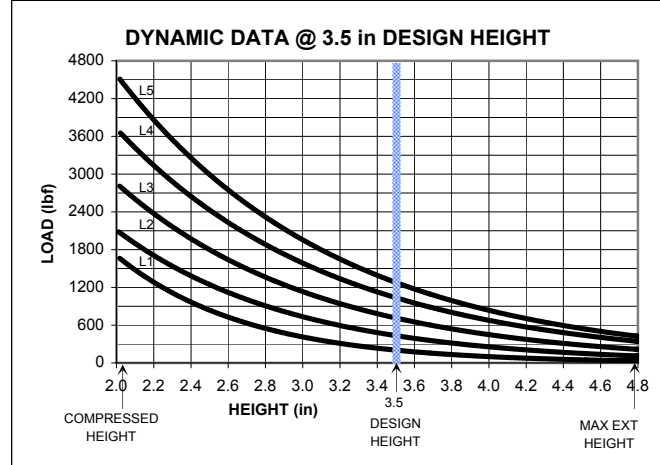
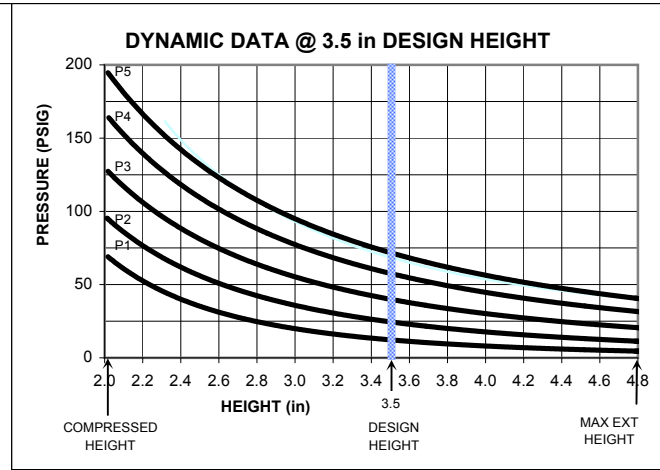
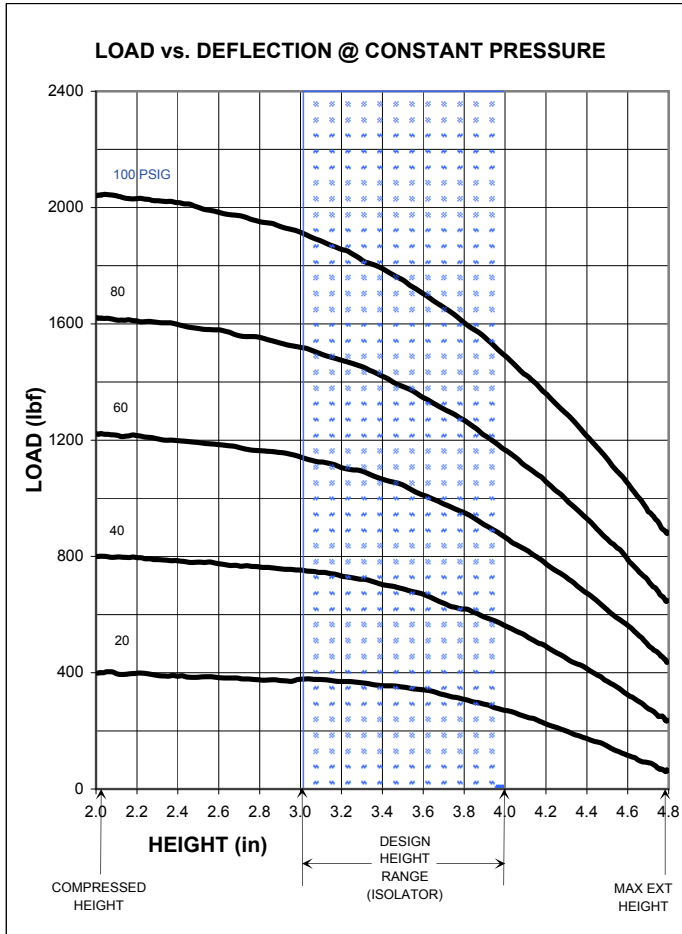

****NOTE: MAXIMUM INFLATION PRESSURE IS 100 PSIG. MAXIMUM JOUNCE PRESSURE IS 200 PSIG. IF YOUR APPLICATION WILL EXCEED THESE LIMITS, CONSULT A GOODYEAR ENGINEERED PRODUCTS AIR SPRINGS REPRESENTATIVE FOR APPLICATION ASSISTANCE.**

CONSTANT PRESSURE CHARACTERISTICS

Assembly Height (in)	Volume @ 100 PSIG (in ³)	Nominal Force (lb)				
		@ 20 PSIG	@ 40 PSIG	@ 60 PSIG	@ 80 PSIG	@ 100 PSIG
4.8	85	60	230	440	620	850
4.5	80	160	380	640	850	1150
4.0	71	280	580	850	1200	1500
3.5	62	360	700	1050	1400	1700
3.0	52	400	750	1150	1500	1900
2.5	42	400	800	1200	1600	2000
2.0	33	420	800	1200	1600	2000

DYNAMIC CHARACTERISTICS

Design Height (in)	Load (lb)	Pressure (PSIG)	Spring Rate (lb/in)	Natural Frequency	
				cpm	Hz
4.0	200	21	375	206	3.43
	450	37	525	185	3.08
	750	57	730	173	2.88
	1050	78	940	166	2.77
3.5	1300	96	1115	163	2.72
	200	16	300	190	3.17
	450	31	445	169	2.82
	750	48	640	164	2.73
3.0	1050	67	840	156	2.60
	1300	83	1020	155	2.58
	200	15	325	192	3.20
	450	28	465	173	2.88
3.0	750	44	645	164	2.73
	1050	61	860	158	2.63
	1300	76	1005	154	2.57

The GOODYEAR (and Winged Foot Design) trademark is used by Veyance Technologies, Inc. under license from The Goodyear Tire & Rubber Company. Goodyear Engineered Products are manufactured and sourced exclusively by Veyance Technologies, Inc. or its affiliates. The following trademarks are licensed to Veyance Technologies, Inc. by The Goodyear Tire & Rubber Company, including Compass, Eagle Pd, Flexten, Gatorback and GY Metric. ©2008 Veyance Technologies, Inc. All Rights Reserved.



1B6-535

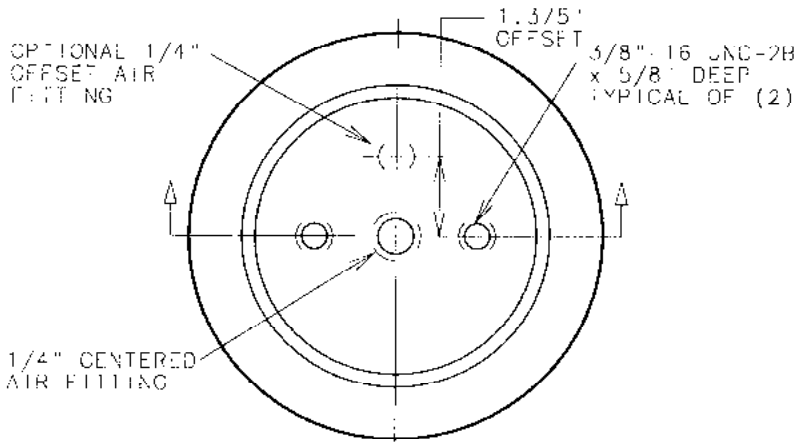

TOP VIEW

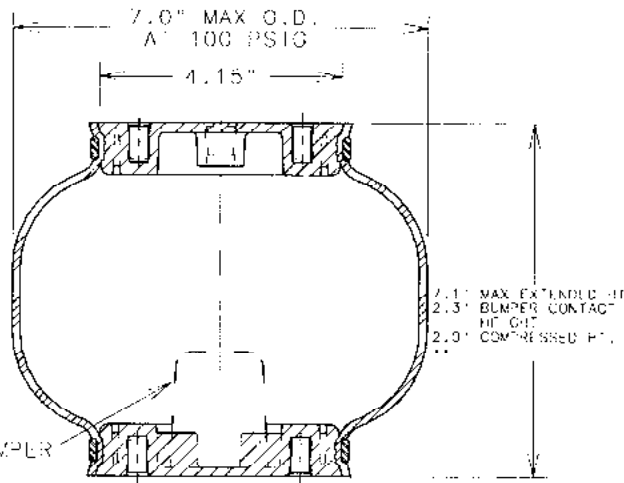

SIDE VIEW

TOP AND BOTTOM SURFACE TO BE FULLY SUPPORTED BY 7.25" DIA. PLATE OR SEE INSTALLATION GUIDELINES SECTION FOR ALTERNATE MOUNTING OPTIONS

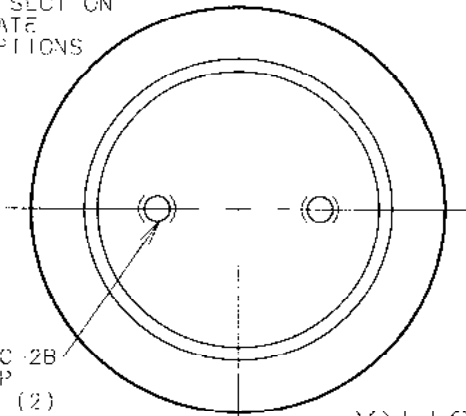

BOTTOM VIEW

ASSEMBLY NUMBER	ELASTOMER	AIR FITTING	BUMPER INCLUDED
1B6-535	WINGPRENE®	1/4"-18 NPTF CENTERED	NO
1B6-536	WINGPRENE®	1/4"-18 NPTF OFFSET 1.375"	NO
1B6-538	WINGPRENE®	1/4"-18 NPTF OFFSET 1.375"	YES

** - AS ACTUATOR DO NOT USE BELOW 3.7 HEIGHT. SEE INSTALLATION GUIDE INFS.

SPRING FEATURES:

- LOAD RANGE (ISOLATOR).....250-2700 lb
- DESIGN HEIGHT RANGE (ISOLATOR).....4.0-6.0 in
- USEABLE STROKE w/o BUMPER (ACTUATOR)....3.4 in
- USEABLE STROKE WITH BUMPER (ACTUATOR).....N/A in
- ASSEMBLY WEIGHT w/o BUMPER.....3.5 lb
- FORCE TO COMPRESS AT 0 PSIG (APPROX.)...120 lb
- NOMINAL FREE STANDING HT. AT 0 PSIG....5.4 in

RECOMMENDED MAX. TORQUE VALUES

5/8"-16 UNC BLIND TAP TYP. OF (2)	1/4"-18 UNC AIR FITTING
240 in-lb 20 ft-lb	240 in-lb 20 ft-lb

NOTE: SEE GUIDELINES FOR PROPER APPLICATION OF THIS PRODUCT

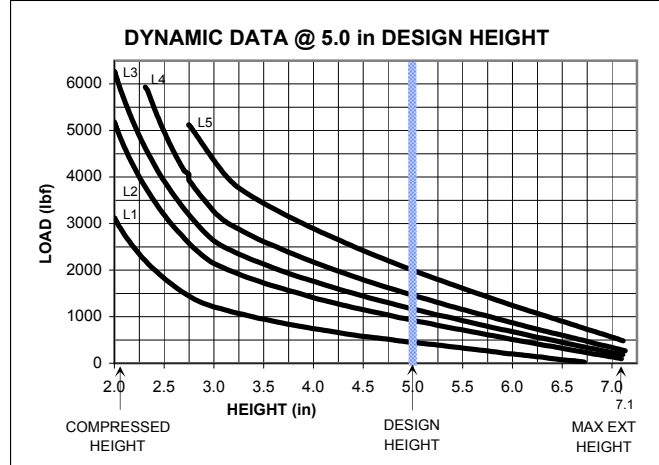
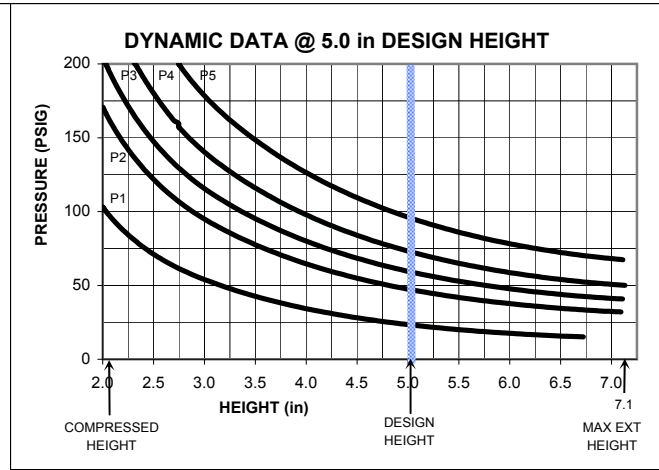
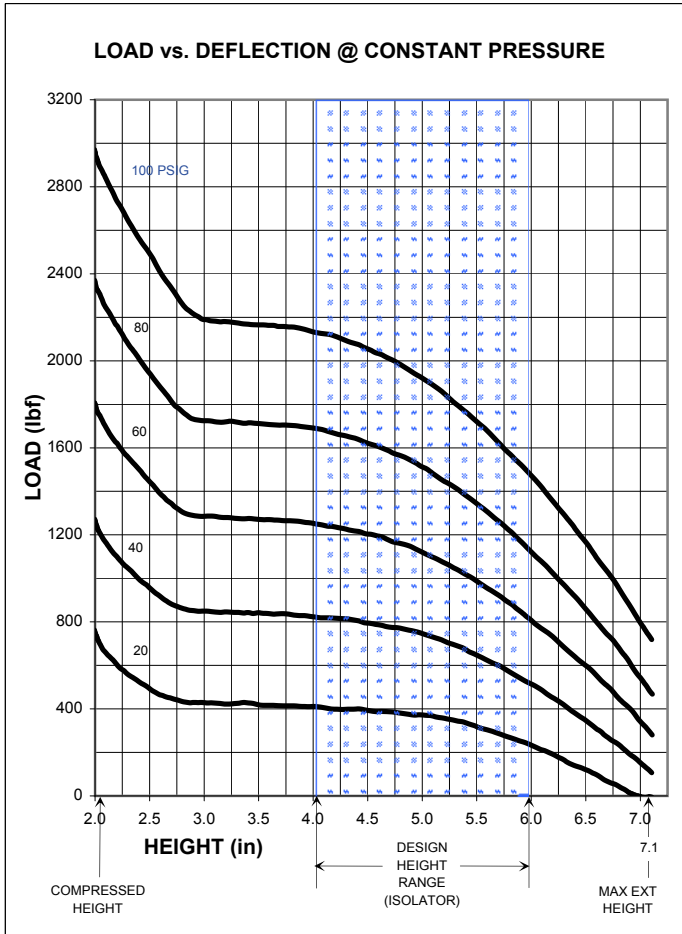

****NOTE: MAXIMUM INFLATION PRESSURE IS 100 PSIG. MAXIMUM JOUNCE PRESSURE IS 200 PSIG. IF YOUR APPLICATION WILL EXCEED THESE LIMITS, CONSULT A GOODYEAR ENGINEERED PRODUCTS AIR SPRINGS REPRESENTATIVE FOR APPLICATION ASSISTANCE.**

CONSTANT PRESSURE CHARACTERISTICS

Assembly Height (in)	Volume @ 100 PSIG (in ³)	Nominal Force (lb)				
		@ 20 PSIG	@ 40 PSIG	@ 60 PSIG	@ 80 PSIG	@ 100 PSIG
7.1	153	10	140	300	500	750
6.0	137	250	520	800	1150	1500
5.5	128	320	700	1000	1350	1700
5.0	117	380	750	1100	1500	1900
4.5	107	380	800	1200	1600	2100
4.0	96	420	850	1250	1700	2100
3.5	86	420	850	1300	1700	2200
3.0	76	440	850	1300	1700	2200
2.5	65	540	1000	1450	2000	2500
2.0	58	750	1250	1800	2300	3000

DYNAMIC CHARACTERISTICS

Design Height (in)	Load (lb)	Pressure (PSIG)	Spring Rate (lb/in)	Natural Frequency	
				cpm	Hz
6.0	500	35	365	160	2.67
	1000	65	595	145	2.42
	1250	79	695	140	2.33
	1500	94	805	138	2.30
5.0	500	25	270	138	2.30
	1000	50	470	129	2.15
	1250	63	565	127	2.12
	1500	75	650	124	2.07
4.0	2000	99	820	120	2.00
	500	22	270	138	2.30
	1000	45	440	125	2.08
	1250	56	520	121	2.02
4.0	1500	68	600	119	1.98
	2000	90	750	116	1.93

The GOODYEAR (and Winged Foot Design) trademark is used by Veyance Technologies, Inc. under license from The Goodyear Tire & Rubber Company. Goodyear Engineered Products are manufactured and sourced exclusively by Veyance Technologies, Inc. or its affiliates. The following trademarks are licensed to Veyance Technologies, Inc. by The Goodyear Tire & Rubber Company, including Compass, Eagle Pd, Flexten, Gatorback and GY Metric. ©2008 Veyance Technologies, Inc. All Rights Reserved.



1B7-540

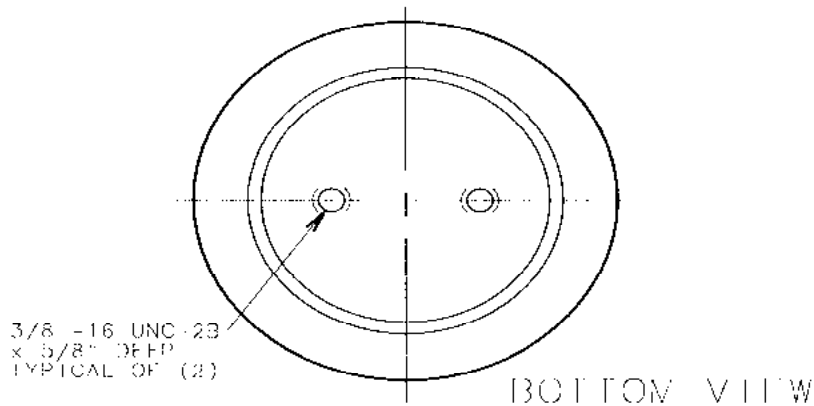
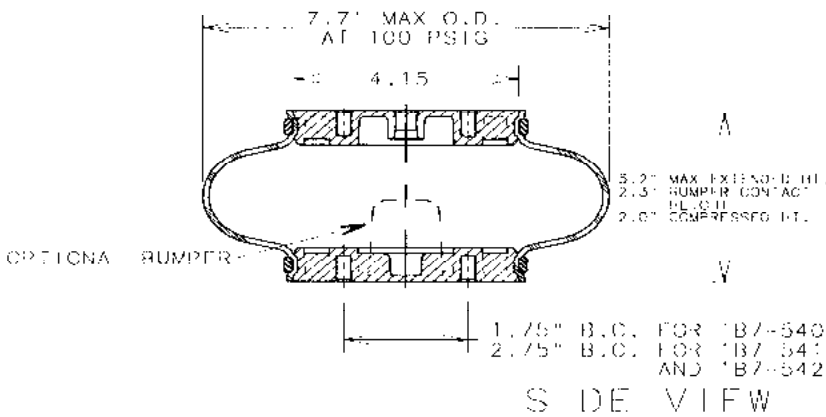
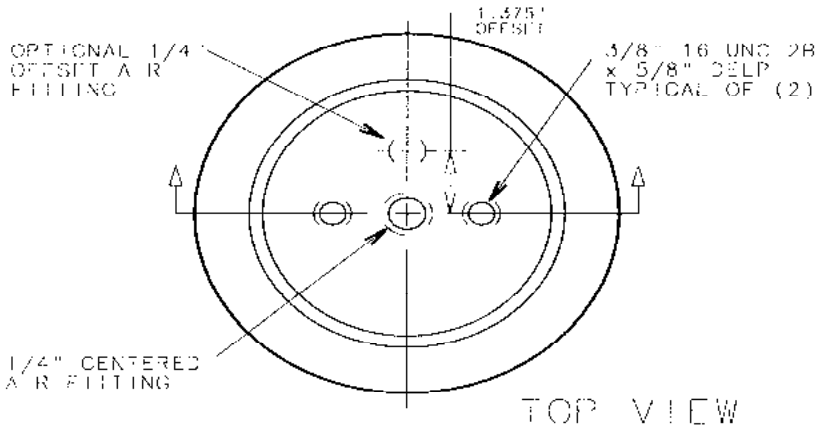

ASSEMBLY NUMBER	ELASTOMER	AIR FITTING	BUMPER INCLUDED
1B7-540	WINGPRENE®	1/4"-18 NPTF CENTERED	NO
1B7-541	WINGPRENE®	1/4"-18 NPTF OFFSET 1.375"	NO
1B7-542	WINGPRENE®	1/4"-18 NPTF OFFSET 1.375"	YES

SPRING FEATURES:

- LOAD RANGE (ISOLATOR).....260-2200 lb
- DESIGN HEIGHT RANGE (ISOLATOR).....3.5-4.5 in
- USEABLE STROKE w/o BUMPER (ACTUATOR).....3.2 in
- USEABLE STROKE WITH BUMPER (ACTUATOR).....2.9 in
- ASSEMBLY WEIGHT w/o BUMPER.....3.5 lb
- FORCE TO COMPRESS AT 0 PSIG (APPROX.).....85 lb
- NOMINAL FREE STANDING HT. AT 0 PSIG.....2.2 in

RECOMMENDED MAX. TORQUE VALUES

3/8" -16 UNC BLIND TAP TYP. OF (2)	1/4"-18 UNC AIR FITTING
240 ft.-lb 20 ft.-lb	240 ft.-lb 20 ft.-lb

NOTE: SEE GUIDELINES FOR PROPER APPLICATION OF THIS PRODUCT

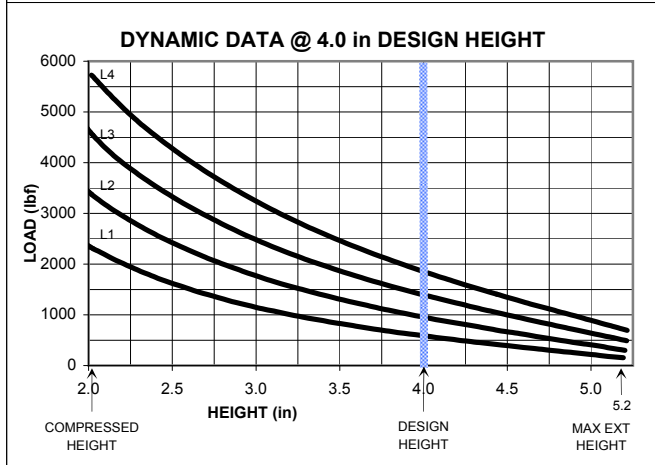
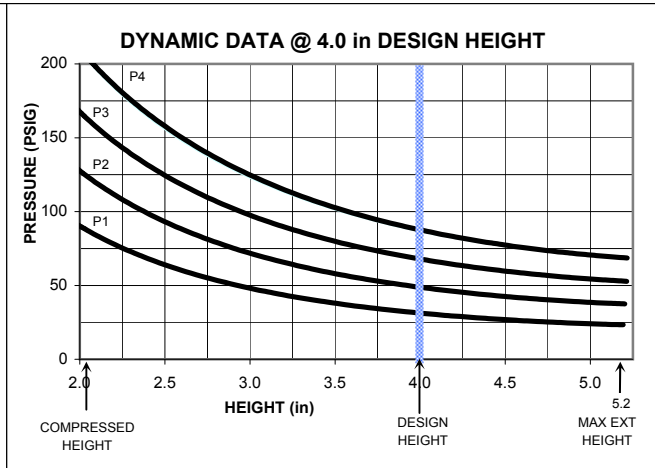
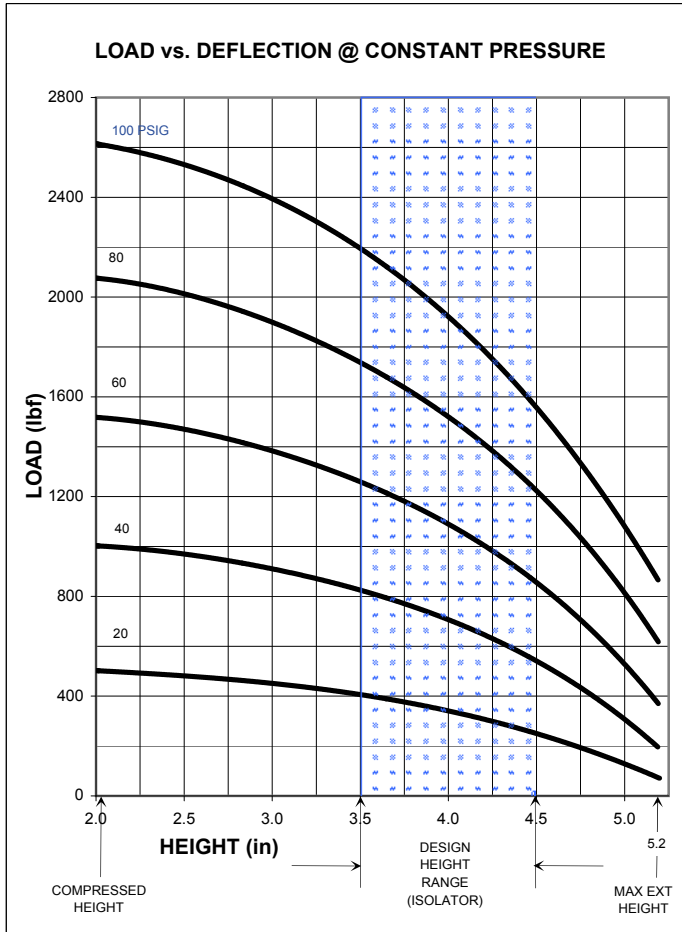

****NOTE: MAXIMUM INFLATION PRESSURE IS 100 PSIG. MAXIMUM JOUNCE PRESSURE IS 200 PSIG. IF YOUR APPLICATION WILL EXCEED THESE LIMITS, CONSULT A GOODYEAR ENGINEERED PRODUCTS AIR SPRINGS REPRESENTATIVE FOR APPLICATION ASSISTANCE.**

CONSTANT PRESSURE CHARACTERISTICS

Assembly Height (in)	Volume @ 100 PSIG (in ³)	Nominal Force (lb)				
		@ 20 PSIG	@ 40 PSIG	@ 60 PSIG	@ 80 PSIG	@ 100 PSIG
		5.2	119	100	200	350
5.0	117	140	340	580	850	1100
4.5	112	260	560	850	1250	1600
4.0	109	340	700	1100	1500	1900
3.5	90	400	800	1250	1700	2200
3.0	78	440	900	1400	1900	2400
2.5	55	480	950	1450	2000	2500
2.0	32	500	1000	1500	2000	2600

DYNAMIC CHARACTERISTICS

Design Height (in)	Load (lb)	Pressure (PSIG)	Spring Rate (lb/in)	Natural Frequency	
				cpm	Hz
4.5	650	42	535	171	2.85
	1000	63	775	165	2.75
	1400	86	1025	160	2.67
4.0	650	34	485	163	2.72
	1000	52	685	155	2.58
	1400	72	910	151	2.52
3.5	1800	91	1120	148	2.47
	650	31	470	159	2.65
	1000	46	650	152	2.53
3.5	1400	64	865	148	2.47
	1800	81	1060	144	2.40

The GOODYEAR (and Winged Foot Design) trademark is used by Veyance Technologies, Inc. under license from The Goodyear Tire & Rubber Company. Goodyear Engineered Products are manufactured and sourced exclusively by Veyance Technologies, Inc. or its affiliates. The following trademarks are licensed to Veyance Technologies, Inc. by The Goodyear Tire & Rubber Company, including Compass, Eagle Pd, Flexten, Gatorback and GY Metric. ©2008 Veyance Technologies, Inc. All Rights Reserved.



1B8-550

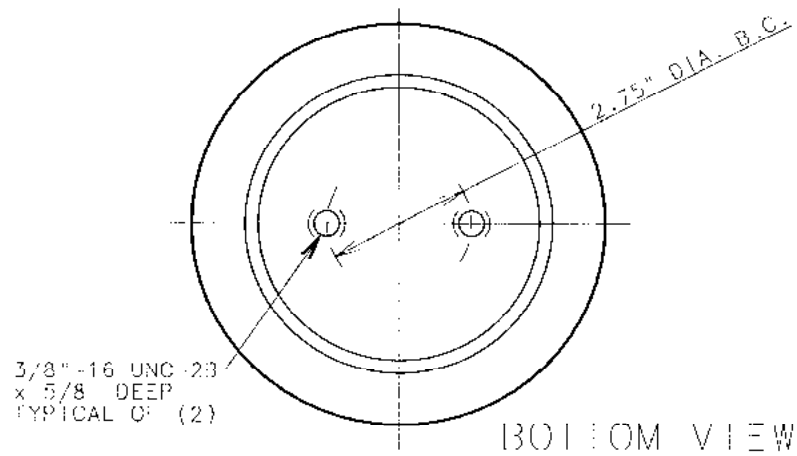
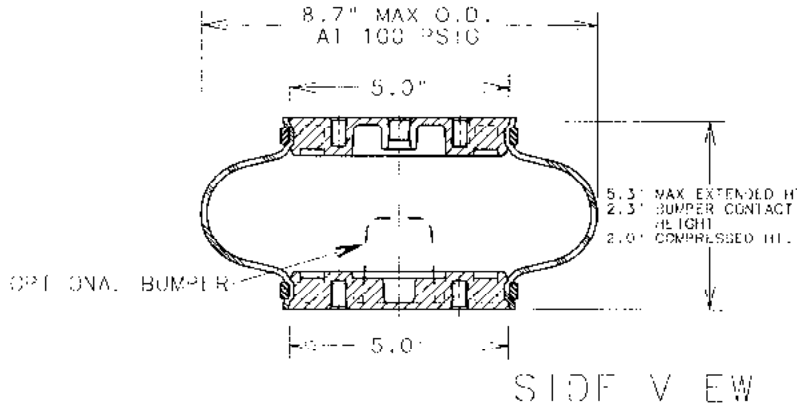
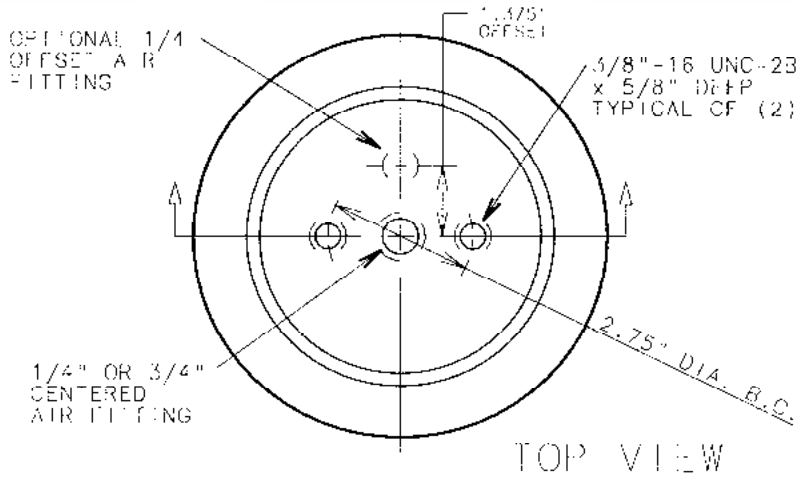

ASSEMBLY NUMBER	ELASTOMER	AIR FITTING	BUMPER INCLUDED
1B8-550	WINGPRENE [®]	1/4" -18 NPTF CENTERED	NO
1B8-552	WINGPRENE [®]	3/4" -14 NPTF CENTERED	NO
1B8-553	WINGPRENE [®]	1/4" -18 NPTF OFFSET 1.375"	NO
1B8-554	WINGPRENE [®]	1/4" -18 NPTF OFFSET 1.375"	YES

SPRING FEATURES:

- LOAD RANGE (ISOLATOR).....520-2900 lb
- DESIGN HEIGHT RANGE (ISOLATOR)....3.75-4.75 in
- USEABLE STROKE w/o BUMPER (ACTUATOR)....3.3 in
- USEABLE STROKE WITH BUMPER (ACTUATOR)....3.0 in
- ASSEMBLY WEIGHT w/o BUMPER.....4.7 lb
- FORCE TO COMPRESS AT 0 PSIG (APPROX.)....25 lb
- NOMINAL FREE STANDING HT. AT 0 PSIG.....2.3 in

RECOMMENDED MAX. TORQUE VALUES

3/8"-16 UNC BLIND TAP TYP. CF (4)	1/4"-18 UNC AIR FITTING	3/4"-14 UNC AIR FITTING
240 in-lb 20 ft-lb	240 in-lb 20 ft-lb	240 in-lb 20 ft-lb

NOTE: SEE GUIDELINES FOR PROPER APPLICATION OF THIS PRODUCT

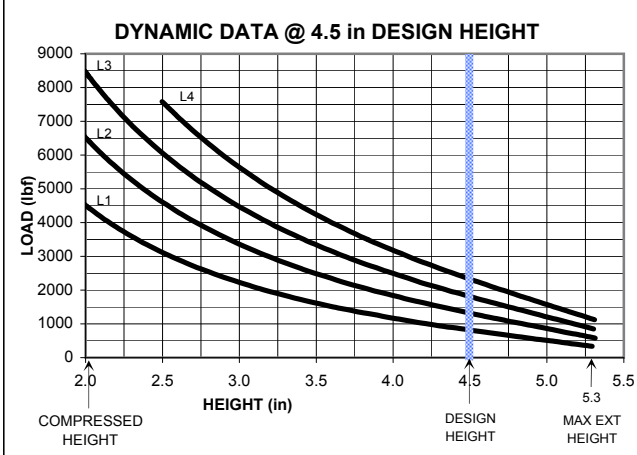
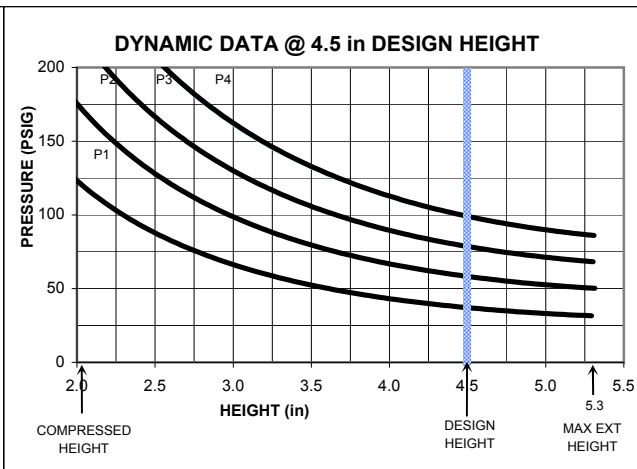
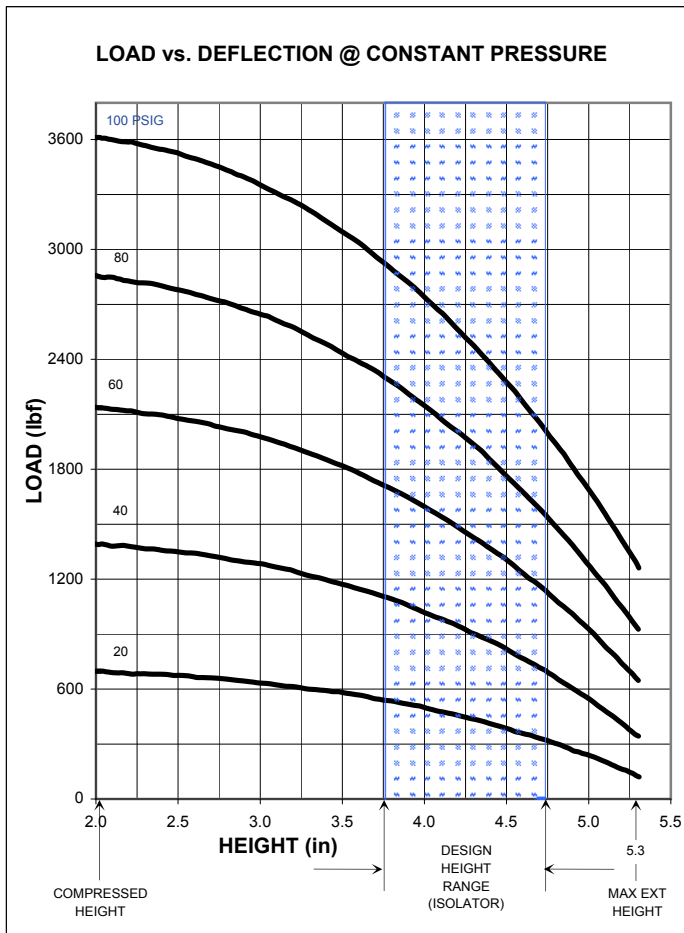

****NOTE: MAXIMUM INFLATION PRESSURE IS 100 PSIG. MAXIMUM JOUNCE PRESSURE IS 200 PSIG. IF YOUR APPLICATION WILL EXCEED THESE LIMITS, CONSULT A GOODYEAR ENGINEERED PRODUCTS AIR SPRINGS REPRESENTATIVE FOR APPLICATION ASSISTANCE.**

CONSTANT PRESSURE CHARACTERISTICS

Assembly Height (in)	Volume @ 100 PSIG (in ³)	Nominal Force (lb)				
		@ 20 PSIG	@ 40 PSIG	@ 60 PSIG	@ 80 PSIG	@ 100 PSIG
5.3	145	100	300	550	800	1100
5.0	138	240	540	900	1000	1600
4.75	133	320	680	1100	1500	2000
4.5	128	380	800	1300	1700	2200
3.75	110	540	1100	1700	2300	2900
3.5	104	580	1150	1900	2500	3100
3.0	90	620	1250	2000	2700	3300
2.5	78	640	1300	2100	2800	3500
2.0	60	660	1350	2100	2800	3600

DYNAMIC CHARACTERISTICS

Design Height (in)	Load (lb)	Pressure (PSIG)	Spring Rate (lb/in)	Natural Frequency	
				cpm	Hz
4.75	850	43	740	176	2.93
	1350	66	1100	170	2.83
	1850	88	1420	165	2.75
4.5	850	38	675	168	2.80
	1350	60	1010	162	2.70
	1850	80	1315	158	2.63
	2400	100	1610	155	2.58
3.75	850	30	620	160	2.67
	1350	47	895	153	2.55
	1850	63	1170	149	2.48
	2400	80	1425	146	2.43

The GOODYEAR (and Winged Foot Design) trademark is used by Veyance Technologies, Inc. under license from The Goodyear Tire & Rubber Company. Goodyear Engineered Products are manufactured and sourced exclusively by Veyance Technologies, Inc. or its affiliates. The following trademarks are licensed to Veyance Technologies, Inc. by The Goodyear Tire & Rubber Company, including Compass, Eagle Pd, Flexten, Gatorback and GY Metric. ©2008 Veyance Technologies, Inc. All Rights Reserved.



1B8-560

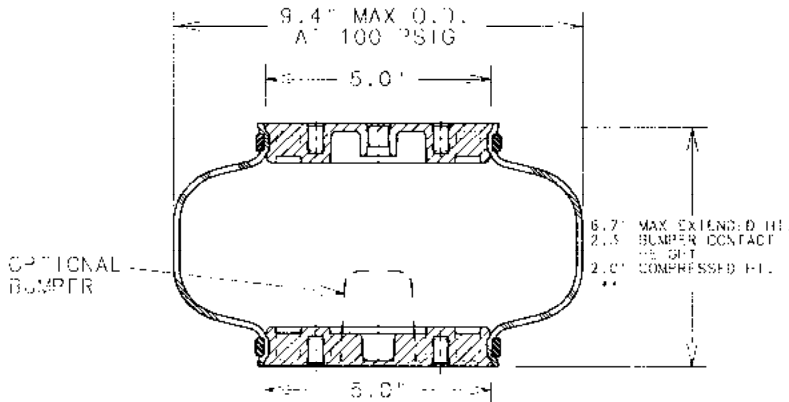
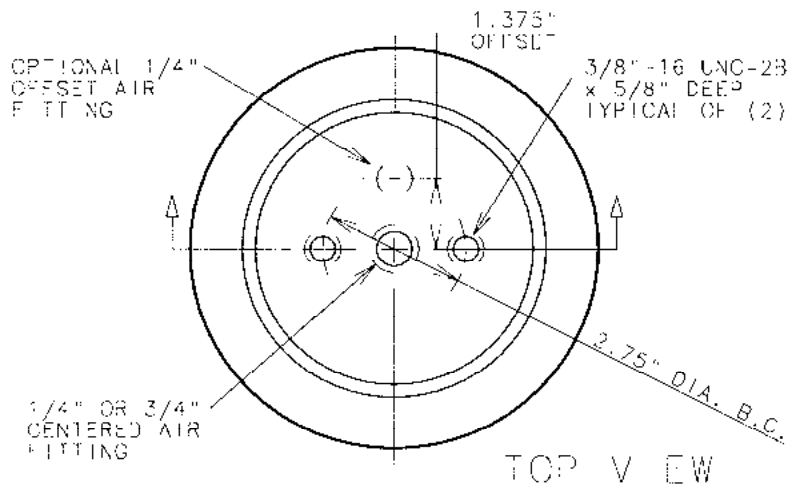

TOP AND BOTTOM SURFACE TO BE FULLY SUPPORTED BY 9.65" DIA. PLATE OR SEE INSTALLATION GUIDELINES SECTION FOR ALTERNATE MOUNTING OPTIONS

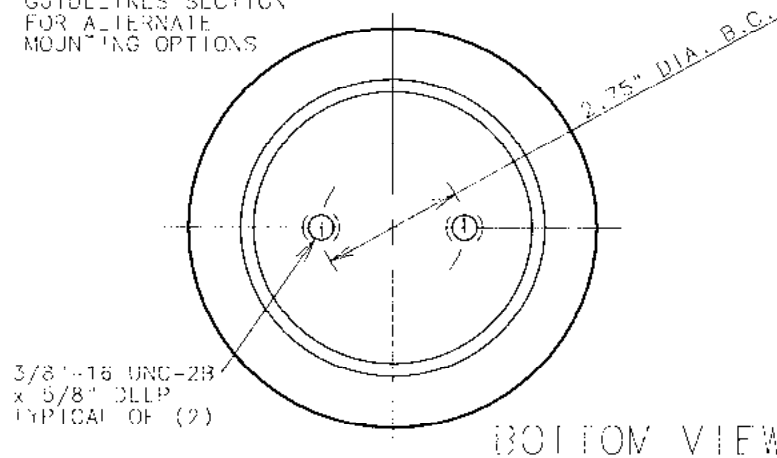

ASSEMBLY NUMBER	ELASTOMER	AIR FITTING	BUMPER INCLUDED
1B8-560	WINGPRENE®	1/4"-18 NPTF CENTERED	NO
1B8-562	WINGPRENE®	3/4"-14 NPTF CENTERED	NO
1B8-563	WINGPRENE®	1/4"-18 NPTF OFFSET 1.375"	NO
1B8-564	WINGPRENE®	1/4"-18 NPTF OFFSET 1.375"	YES

** - AS ACTUATOR DO NOT USE BELOW 3.5' HEIGHT. SEE INSTALLATION GUIDELINES.

SPRING FEATURES:

- LOAD RANGE (ACTUATOR).....180-3500 lb
- DESIGN HEIGHT RANGE (ISOLATOR).....4.0-6.5 ft
- USEABLE STROKE w/o BUMPER (ACTUATOR).....3.2 ft
- USEABLE STROKE WITH BUMPER (ACTUATOR).....N.A. ft
- ASSEMBLY WEIGHT w/o BUMPER.....4.8 lb
- FORCE TO COMPRESS AT 0 PSIG (APPROX.).....25 lb
- NOMINAL FREE STANDING Ht. AT 0 PSIG.....3.3 ft

RECOMMENDED MAX. TORQUE VALUES

3/8"-16 UNC BUSHING CAP TYP. OF (4)	1/4"-18 UNC AIR FITTING	3/4"-14 UNC AIR FITTING
240 ft-lb 20 ft-lb	240 ft-lb 20 ft-lb	240 ft-lb 20 ft-lb

NOTE: SEE GUIDELINES FOR PROPER APPLICATION OF THIS PRODUCT

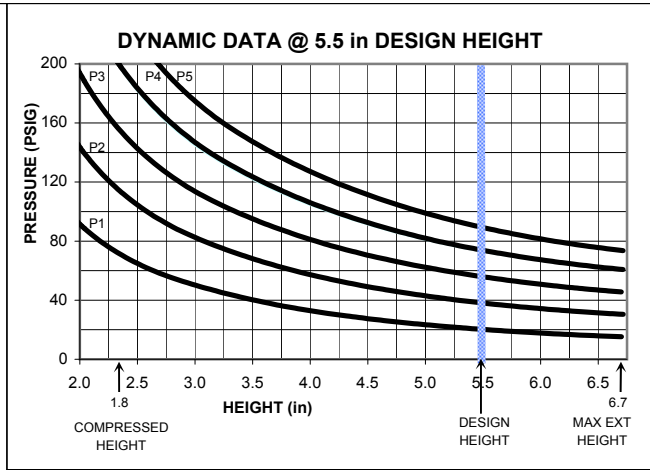
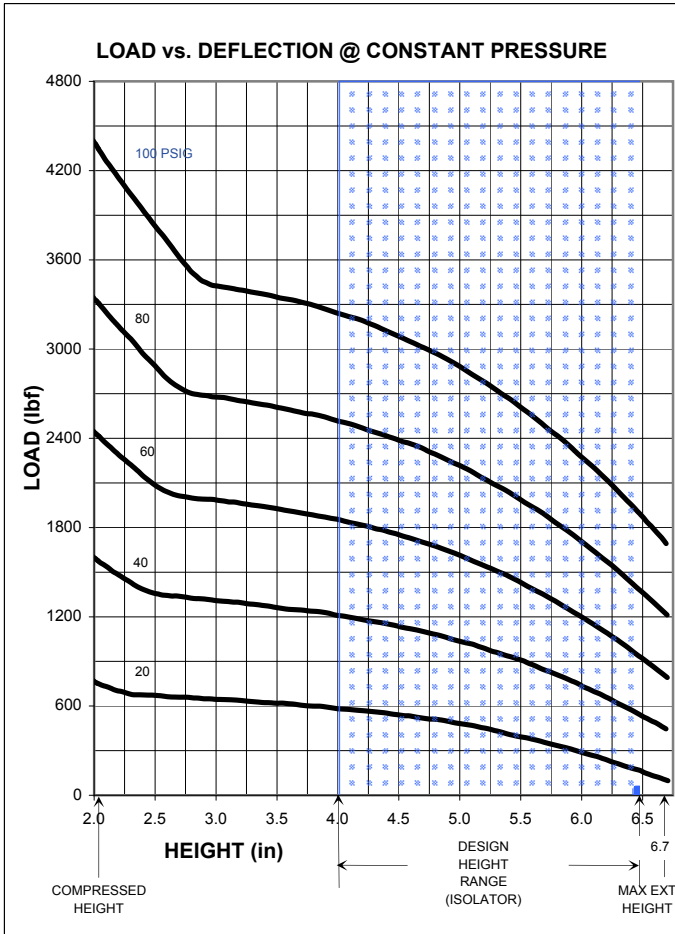

****NOTE: MAXIMUM INFLATION PRESSURE IS 100 PSIG. MAXIMUM JOUNCE PRESSURE IS 200 PSIG. IF YOUR APPLICATION WILL EXCEED THESE LIMITS, CONSULT A GOODYEAR ENGINEERED PRODUCTS AIR SPRINGS REPRESENTATIVE FOR APPLICATION ASSISTANCE.**

CONSTANT PRESSURE CHARACTERISTICS

Assembly Height (in)	Volume @ 100 PSIG (in ³)	Nominal Force (lb)				
		@ 20 PSIG	@ 40 PSIG	@ 60 PSIG	@ 80 PSIG	@ 100 PSIG
6.7	239	80	450	750	1200	1600
6.5	235	180	540	950	1450	1900
5.5	208	420	900	1450	2000	2700
4.5	178	560	1150	1800	2400	3100
4.0	162	600	1200	1850	2600	3300
3.5	146	640	1300	1900	2700	3400
3.0	129	680	1350	2000	2700	3500
2.5	111	700	1350	2100	3000	3900
2.0	104	800	1650	2500	3500	4500

DYNAMIC CHARACTERISTICS

Design Height (in)	Load (lb)	Pressure (PSIG)	Spring Rate (lb/in)	Natural Frequency	
				cpm	Hz
6.5	500	32	480	184	3.07
	1000	56	725	160	2.67
	1500	78	965	151	2.52
	2000	98	1165	142	2.37
5.5	500	22	355	158	2.63
	1000	40	545	138	2.30
	1500	58	725	130	2.17
	2000	76	905	126	2.10
	2500	91	1045	122	2.03
4.0	500	15	322	150	2.50
	1000	31	520	134	2.23
	1500	46	670	125	2.08
	2000	61	860	122	2.03
	2500	76	1005	119	1.98

The GOODYEAR (and Winged Foot Design) trademark is used by Veyance Technologies, Inc. under license from The Goodyear Tire & Rubber Company. Goodyear Engineered Products are manufactured and sourced exclusively by Veyance Technologies, Inc. or its affiliates. The following trademarks are licensed to Veyance Technologies, Inc. by The Goodyear Tire & Rubber Company, including Compass, Eagle Pd, Flexten, Gatorback and GY Metric. ©2008 Veyance Technologies, Inc. All Rights Reserved.



1B9-202

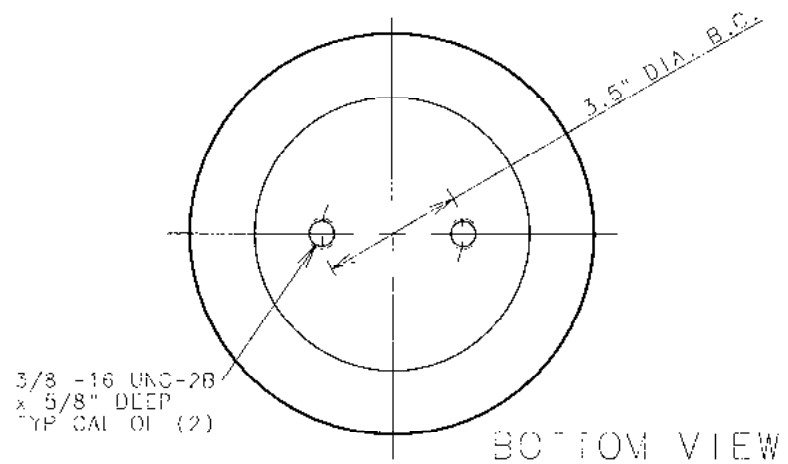
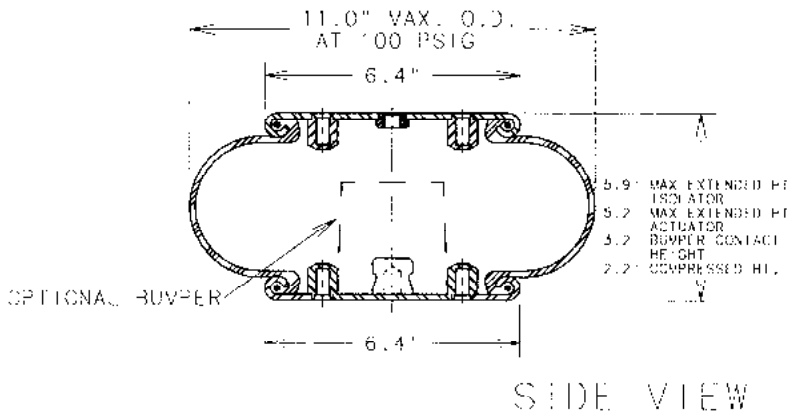
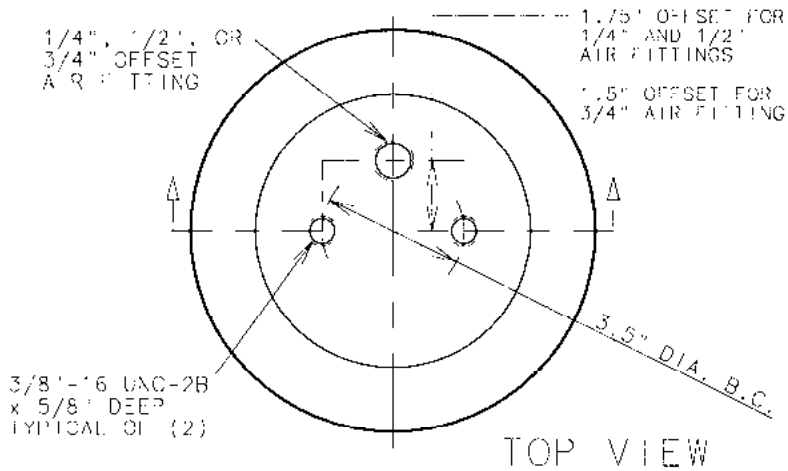

ASSEMBLY NUMBER	ELASTOMER	AIR FITTING	BUMPER INCLUDED
1B9-202	NAT. RUBBER	1/4"-18 NPTF OFFSET 1.75"	NO
1B9-201	NAT. RUBBER	1/4"-18 NPTF OFFSET 1.75"	YES
1B9-204	NAT. RUBBER	1/2"-14 NPTF OFFSET 1.75"	NO
1B9-205	NAT. RUBBER	1/2"-14 NPTF OFFSET 1.75"	YES
1B9-207	NAT. RUBBER	3/4"-14 NPTF OFFSET 1.5"	NO
1B9-208	NAT. RUBBER	3/4"-14 NPTF OFFSET 1.5"	YES
575913201 FLEXIMETER ONLY	NAT. RUBBER	----	---

SPRING FEATURES:

- LOAD RANGE (ISOLATOR).....540-3900 lb
- DESIGN HEIGHT RANGE (ISOLATOR).....4.5-5.0 in
- USEABLE STROKE w/o BUMPER (ACTUATOR).....3.0 in
- USEABLE STROKE WITH BUMPER (ACTUATOR).....2.0 in
- ASSEMBLY WEIGHT.....8.5 lb
- FORCE TO COMPRESS AT 0 PSIG (APPROX.).....20 lb
- NOMINAL FREE STANDING HT. AT 0 PSIG.....9.7 in

RECOMMENDED MAX. TORQUE VALUES

3/8"-16 UNC BLIND CAP TYP. OF (4)	1/4"-18 UNC AIR FITTING	1/2"-14 UNC AIR FITTING	3/4"-14 UNC AIR FITTING
300 in-lb 25 ft-lb	240 in-lb 20 ft-lb	240 in-lb 20 ft-lb	240 in-lb 20 ft-lb

NOTE: SEE GUIDELINES FOR PROPER APPLICATION OF THIS PRODUCT

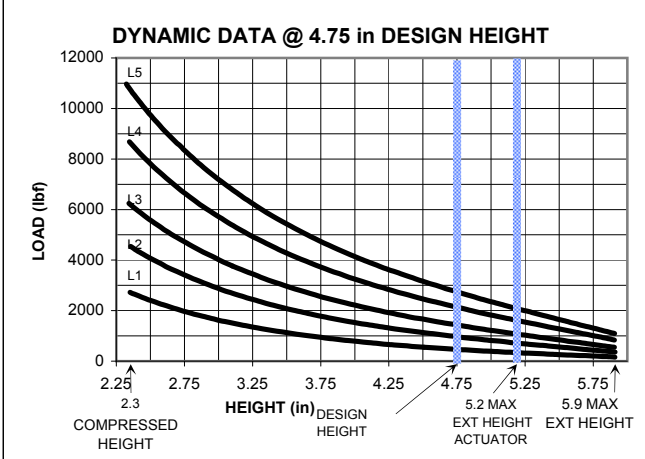
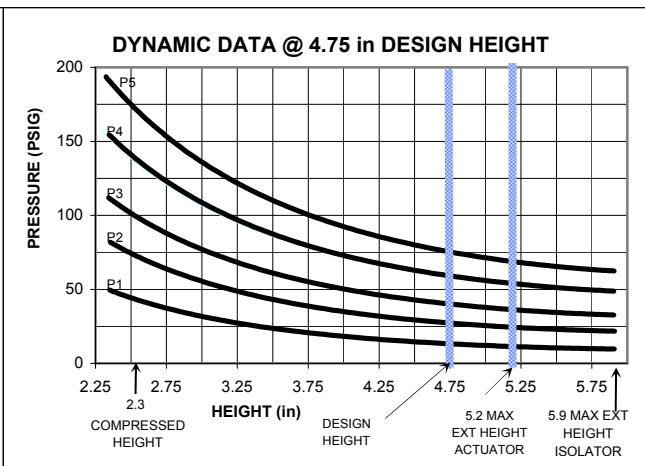
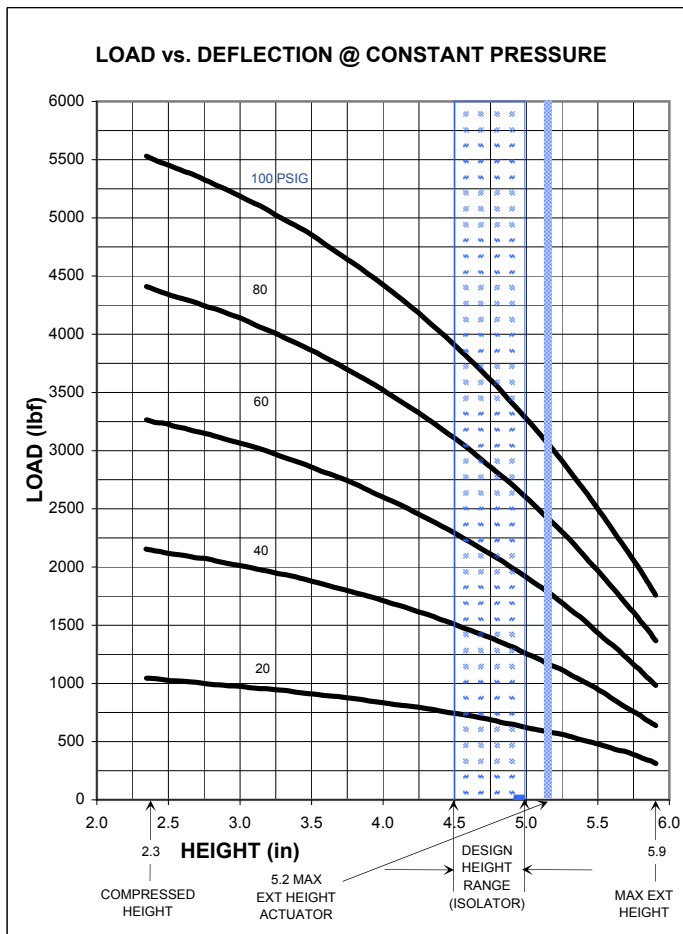

****NOTE: MAXIMUM INFLATION PRESSURE IS 100 PSIG. MAXIMUM JOUNCE PRESSURE IS 200 PSIG. IF YOUR APPLICATION WILL EXCEED THESE LIMITS, CONSULT A GOODYEAR ENGINEERED PRODUCTS AIR SPRINGS REPRESENTATIVE FOR APPLICATION ASSISTANCE.**

CONSTANT PRESSURE CHARACTERISTICS

Assembly Height (in)	Volume @ 100 PSIG (in ³)	Nominal Force (lb)				
		@ 20 PSIG	@ 40 PSIG	@ 60 PSIG	@ 80 PSIG	@ 100 PSIG
		5.9	283	280	560	850
5.5	270	480	950	1450	1900	2500
5.2	260	580	1140	1700	2300	2900
5.0	253	640	1250	1900	2600	3200
4.75	244	700	1400	2100	2800	3600
4.5	233	750	1500	2300	3100	3900
4.0	211	850	1700	2600	3500	4400
3.5	187	900	1900	2900	3900	4900
3.0	162	1000	2000	3100	4200	5200
2.5	136	1050	2100	3200	4400	5500
2.3	126	1100	2200	3300	4500	5600

DYNAMIC CHARACTERISTICS

Design Height (in)	Load (lb)	Pressure (PSIG)	Spring Rate (lb/in)	Natural Frequency	
				cpm	Hz
5.0	500	15	355	158	2.63
	1000	31	695	157	2.62
	1500	46	990	153	2.55
	2200	67	1405	150	2.50
4.75	500	14	360	159	2.65
	1000	28	640	150	2.50
	1500	41	940	149	2.48
	2200	61	1310	145	2.42
4.5	500	13	360	158	2.63
	1000	25	630	150	2.50
	1500	38	900	146	2.43
	2200	55	1255	143	2.38
	2800	70	1570	141	2.35

The GOODYEAR (and Winged Foot Design) trademark is used by Veyance Technologies, Inc. under license from The Goodyear Tire & Rubber Company. Goodyear Engineered Products are manufactured and sourced exclusively by Veyance Technologies, Inc. or its affiliates. The following trademarks are licensed to Veyance Technologies, Inc. by The Goodyear Tire & Rubber Company, including Compass, Eagle Pd, Flexten, Gatorback and GY Metric. ©2008 Veyance Technologies, Inc. All Rights Reserved.



1B12-313

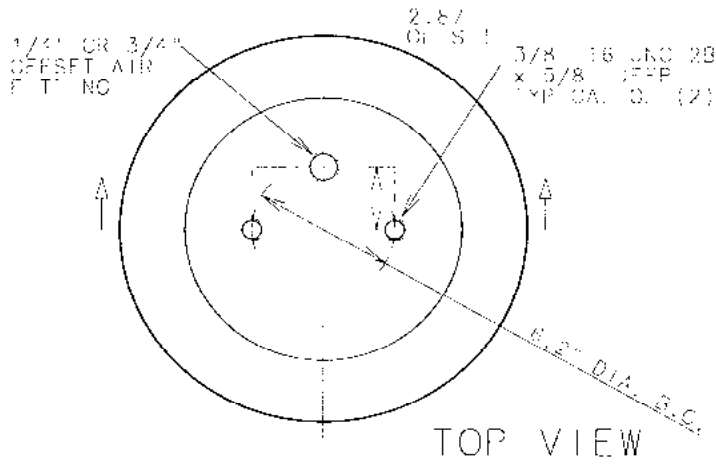

TOP VIEW

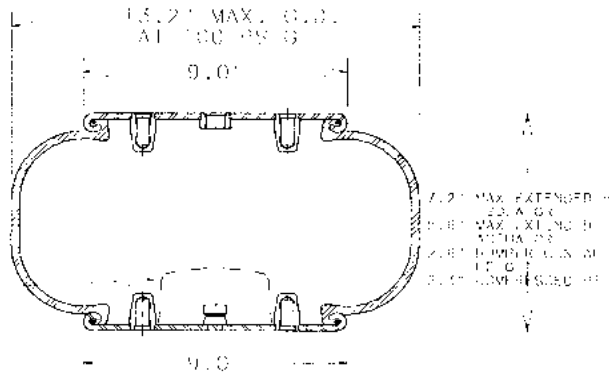

SIDE VIEW

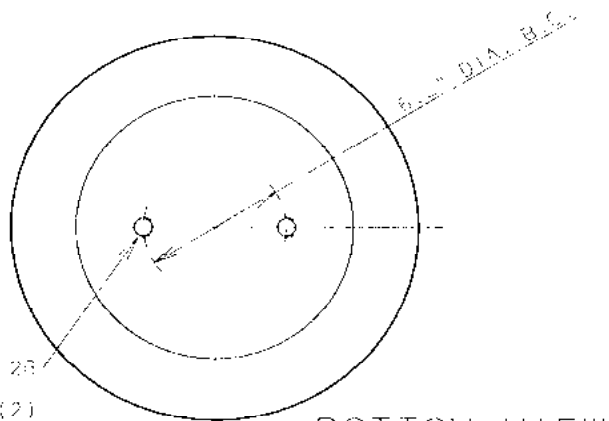

BOTTOM VIEW

ASSEMBLY NUMBER	SLATCOVER	AIR HEIGHT	BUMPER INCLUDED
1B12-313	NAT. RUBBER	1/4" 18 NPTF OFFSET 2.97"	NO
1B12-301	NAT. RUBBER	1/4" 18 NPTF OFFSET 2.97"	YES
1B12-304	NAT. RUBBER	3/2" 14 NPTF OFFSET 2.97"	NO
1B12-305	NAT. RUBBER	3/2" 14 NPTF OFFSET 2.97"	YES
5789-3301 (MEMBER ONLY)	NAT. RUBBER		--

SPR NG FEATURES:

- LOAD RANGE (50 ATG).....1500-6000 LB
- DESIGN VELOCITY RANGE (SQ. A OR).....3.0-4.0 IN
- INSTANT STRIKE W/O BUMPER (AG. ATG).....3.4 IN
- OFF-ASIS STRIKE WITH BUMPER (AG. ATG).....3.0 IN
- ASSEMBLY WEIGHT.....10.0 LB
- OPER. TO COMPLETE AT 0.0 PSI (APPROX).....150 LB
- MAX. NAT. FREE STANDING H. AT 0.0 PSI.....2.9 IN

RECOMMENDED MAX. TORQUE VALUES

5/8" 18 UNC DI. TAP TYP. D. (2)	1/4" 18 UNC AIR FITTING	3/4" 14 UNC AIR FITTING
5.0 (1.5)	2.0 (1.5)	2.0 (1.5)

NOTE: SEE GUIDELINES FOR PROPER APPLICATION OF THIS PRODUCT

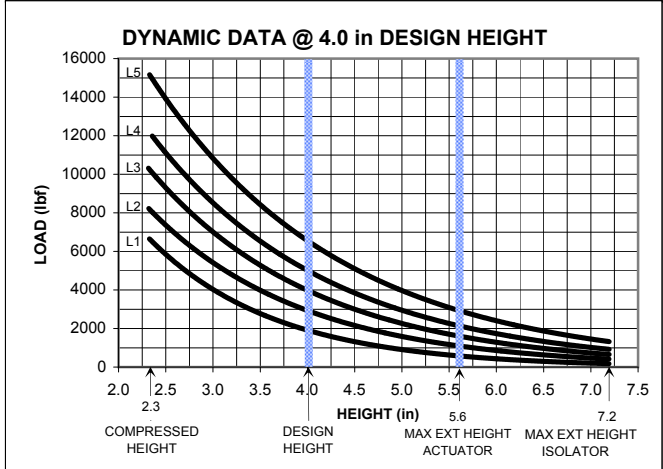
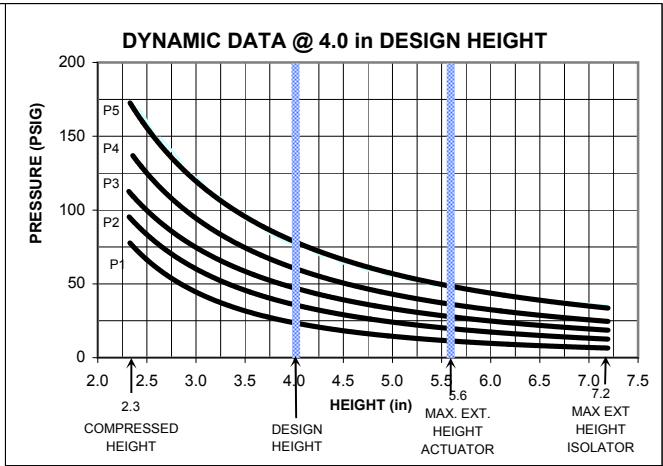
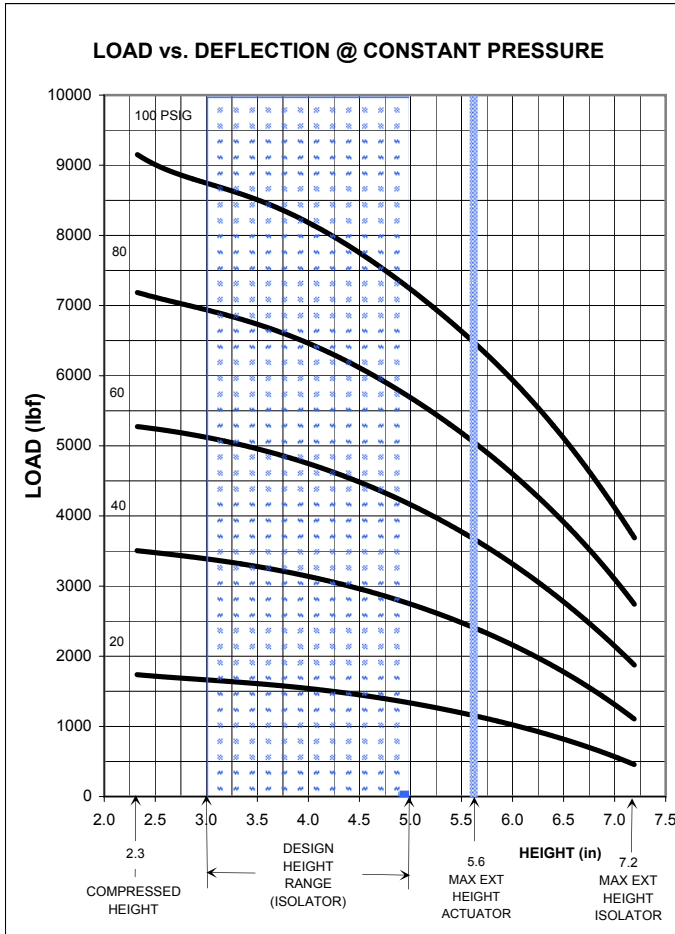

****NOTE: MAXIMUM INFLATION PRESSURE IS 100 PSIG. MAXIMUM JOUNCE PRESSURE IS 200 PSIG. IF YOUR APPLICATION WILL EXCEED THESE LIMITS, CONSULT A GOODYEAR ENGINEERED PRODUCTS AIR SPRINGS REPRESENTATIVE FOR APPLICATION ASSISTANCE.**

CONSTANT PRESSURE CHARACTERISTICS

Assembly Height (in)	Volume @ 100 PSIG (in ³)	Nominal Force (lb)				
		@ 20 PSIG	@ 40 PSIG	@ 60 PSIG	@ 80 PSIG	@ 100 PSIG
		7.2	618	440	1050	1800
6.5	569	800	1800	2800	3900	5100
6.0	531	1050	2200	3100	4600	6000
5.6	497	1150	2450	3650	5050	6550
5.5	489	1200	2500	3800	5200	6700
5.0	445	1350	2800	4200	5700	7300
4.5	400	1450	3000	4500	6100	7800
4.0	354	1500	3100	4800	6500	8200
3.5	311	1600	3300	5000	6800	8500
3.0	263	1700	3400	5100	7000	8800
2.3	190	1700	3500	5300	7100	9100

DYNAMIC CHARACTERISTICS

Design Height (in)	Load (lb)	Pressure (PSIG)	Spring Rate (lb/in)	Natural Frequency	
				cpm	Hz
5.0	2000	28	1040	135	2.25
	3000	42	1415	129	2.15
	4000	55	1810	127	2.12
	5000	69	2175	124	2.07
	6500	89	2725	121	2.02
4.0	2000	25	1225	147	2.45
	3000	37	1640	139	2.32
	4000	49	2055	135	2.25
3.0	5000	61	2475	132	2.20
	6500	79	3070	129	2.15
	2000	23	1570	167	2.78
	3000	34	2120	158	2.63
	4000	46	2600	151	2.52
3.0	5000	57	3425	148	2.47
	6500	74	3895	145	2.42

The GOODYEAR (and Winged Foot Design) trademark is used by Veyance Technologies, Inc. under license from The Goodyear Tire & Rubber Company. Goodyear Engineered Products are manufactured and sourced exclusively by Veyance Technologies, Inc. or its affiliates. The following trademarks are licensed to Veyance Technologies, Inc. by The Goodyear Tire & Rubber Company, including Compass, Eagle Pd, Flexten, Gatorback and GY Metric. ©2008 Veyance Technologies, Inc. All Rights Reserved.



1B14-350

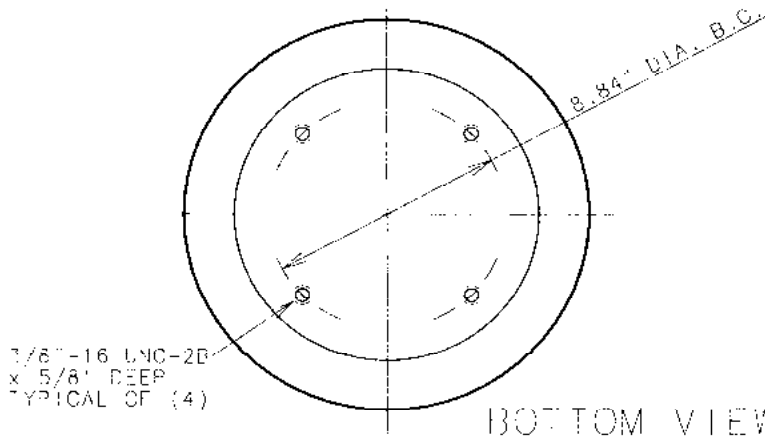
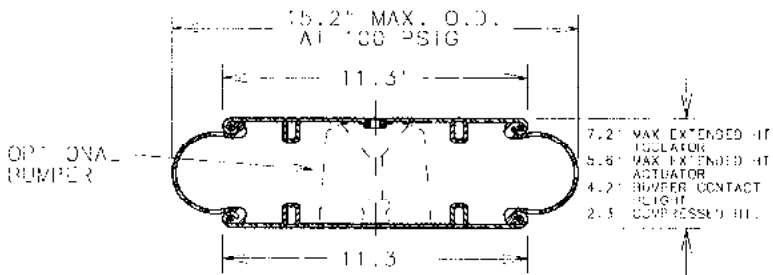
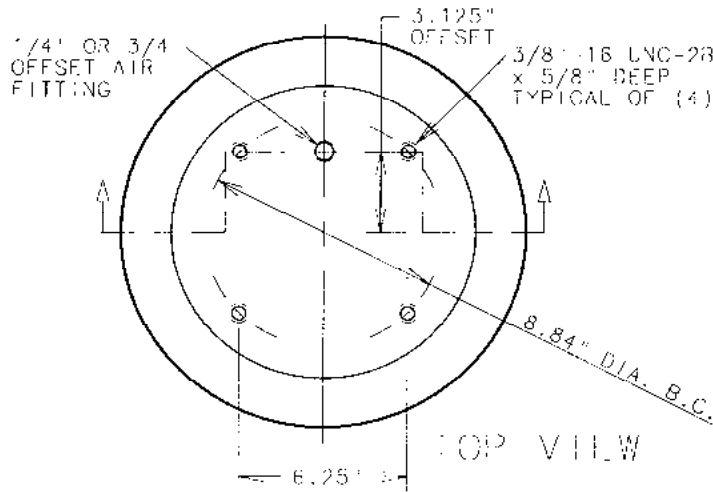

ASSEMBLY NUMBER	ELASTOMER	AIR FITTING	BUMPER INCLUDED
1B14-350	NAT. RUBBER	1/4"-18 SPTF OFFSET 3.125"	NO
1B14-351	NAT. RUBBER	1/4"-18 SPTF OFFSET 3.125"	YES
1B14-352	NAT. RUBBER	3/4"-14 SPTF OFFSET 3.125"	NO
1B14-353	NAT. RUBBER	3/4"-14 SPTF OFFSET 3.125"	YES
579913351 EXEMPT MEMBER ONLY	NAT. RUBBER	---	---

SPRING FEATURES:

- LOAD RANGE (ISOLATOR).....1900-11900 lb
- DESIGN HEIGHT RANGE (ISOLATOR).....4.0-5.25 in
- USEABLE STROKE w/o BUMPER (ACTUATOR).....3.3 in
- USEABLE STROKE WITH BUMPER (ACTUATOR).....1.4 in
- ASSEMBLY WEIGHT.....15.0 lb
- FORCE TO COMPRESS AT 0 PSIG (APPROX.).....120 lb
- NOMINAL FREE STANDING HT. AT 0 PSIG.....3.75 in

RECOMMENDED MAX. TORQUE VALUES

3/8"-16 UNC BLEND CAP TYP. OF (8)	1/4"-18 UNC AIR FITTING	3/4"-14 UNC AIR FITTING
300 in-lb 25 ft-lb	240 in-lb 20 ft-lb	240 in-lb 20 ft-lb

NOTE: SEE GUIDELINES FOR PROPER APPLICATION OF THIS PRODUCT

LOAD vs. DEFLECTION @ CONSTANT PRESSURE

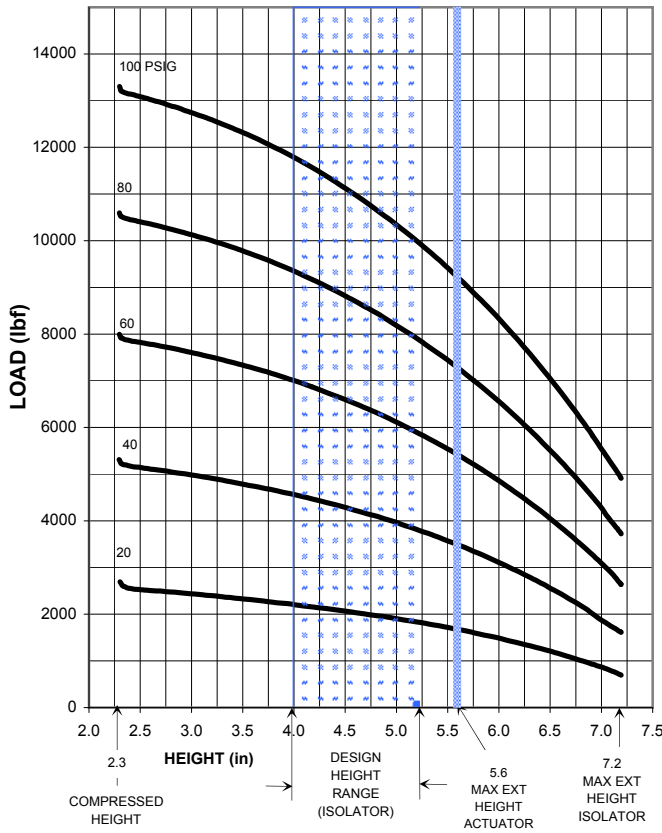

DYNAMIC DATA @ 4.25 in DESIGN HEIGHT

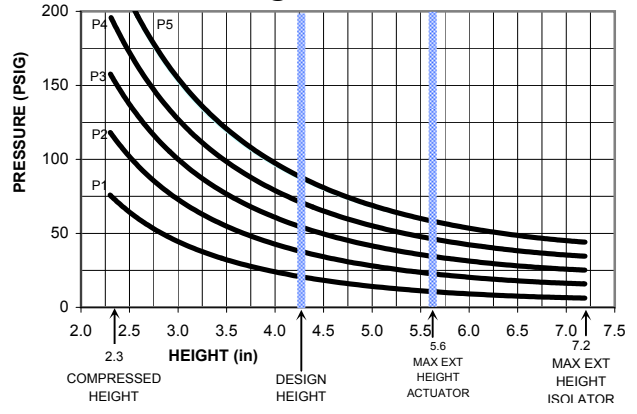

DYNAMIC DATA @ 4.25 in DESIGN HEIGHT

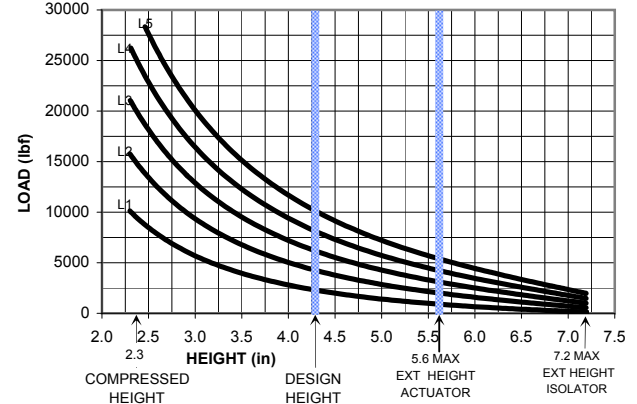

****NOTE: MAXIMUM INFLATION PRESSURE IS 100 PSIG. MAXIMUM JOUNCE PRESSURE IS 200 PSIG. IF YOUR APPLICATION WILL EXCEED THESE LIMITS, CONSULT A GOODYEAR ENGINEERED PRODUCTS AIR SPRINGS REPRESENTATIVE FOR APPLICATION ASSISTANCE.**

CONSTANT PRESSURE CHARACTERISTICS

Assembly Height (in)	Volume @ 100 PSIG (in ³)	Nominal Force (lb)				
		@ 20 PSIG	@ 40 PSIG	@ 60 PSIG	@ 80 PSIG	@ 100 PSIG
7.2	824	680	1600	2600	3700	4900
6.5	762	1200	2600	4000	5500	7100
6.0	709	1500	3100	4900	6600	8400
5.6	663	1700	3500	5400	7300	9300
5.25	621	1900	3800	5900	7900	10000
5.0	590	2000	4000	6200	8300	10500
4.25	496	2200	4600	6900	9200	11700
4.0	464	2300	4700	7100	9500	11900
3.5	399	2400	4900	7400	9900	12500
3.0	335	2500	5100	7700	10300	12900
2.3	247	2600	5200	7900	10500	13300

DYNAMIC CHARACTERISTICS

Design Height (in)	Load (lb)	Pressure (PSIG)	Spring Rate (lb/in)	Natural Frequency	
				cpm	Hz
5.25	2500	26	1420	141	2.35
	4500	46	2280	133	2.22
	6500	65	3065	129	2.15
	8500	85	3895	127	2.12
4.25	2500	22	1625	152	2.53
	4500	39	2505	140	2.33
	6500	56	3340	135	2.25
	8500	73	4215	132	2.20
4.0	10500	90	5035	130	2.17
	2500	21	1755	157	2.62
	4500	38	2635	144	2.40
	6500	55	3495	138	2.30
	8500	71	4390	135	2.25
10500	88	5260	133	2.22	

The GOODYEAR (and Winged Foot Design) trademark is used by Veyance Technologies, Inc. under license from The Goodyear Tire & Rubber Company. Goodyear Engineered Products are manufactured and sourced exclusively by Veyance Technologies, Inc. or its affiliates. The following trademarks are licensed to Veyance Technologies, Inc. by The Goodyear Tire & Rubber Company, including Compass, Eagle Pd, Flexten, Gatorback and GY Metric. ©2008 Veyance Technologies, Inc. All Rights Reserved.



1B15-375

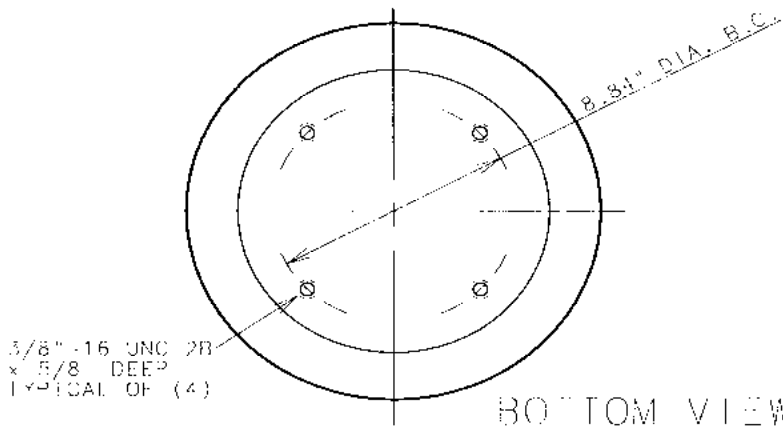
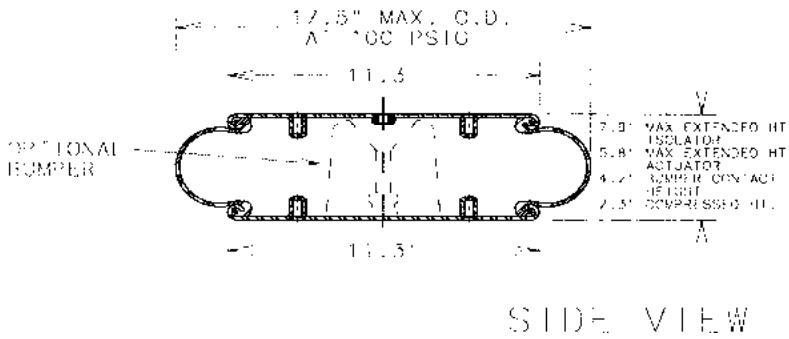
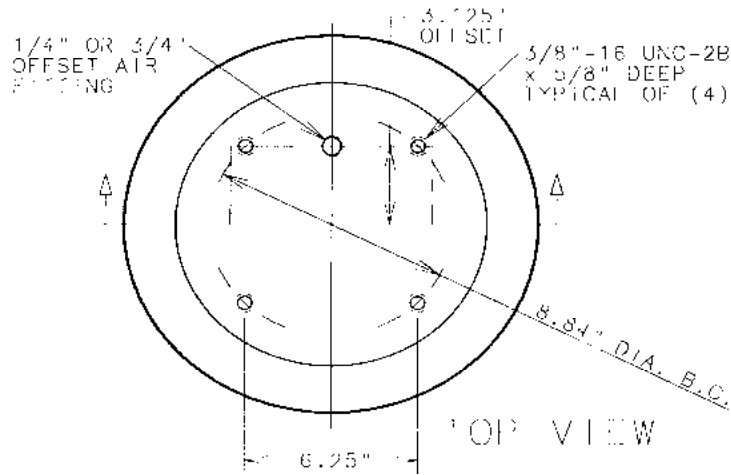

ASSEMBLY NUMBER	PLASTOVER	AIR FITTING	BUMPER INCLUDED
1B15-375	NAT. RUBBER	1/4"-18 NPTF OFFSET 3.125	NO
1B15-376	NAT. RUBBER	1/4"-18 NPTF OFFSET 3.125	YES
1B15-377	NAT. RUBBER	3/4"-14 NPTF OFFSET 3.125	NO
1B15-378	NAT. RUBBER	3/4"-14 NPTF OFFSET 3.125	YES
578913375 FLEXMEMBER ONLY	NAT. RUBBER	----	--

SPRING FEATURES:

- LOAD RANGE (ISOLATOR).....2200-13700 lb
- DESIGN HEIGHT RANGE (ISOLATOR).....4.4-5.4 in
- USEABLE STROKE w/o BUMPER (ACTUATOR)....3.5 in
- USEABLE STROKE WITH BUMPER (ACTUATOR)....1.6 in
- ASSEMBLY WEIGHT.....16.7 lb
- FORCE TO COMPRESS AT 0 PSIG (APPROX.)....10 lb
- NOMINAL FREE STANDING HT. AT 0 PSIG.....2.9 in

RECOMMENDED MAX. TORQUE VALUES

5/8"-16 UNC BLIND TAP TYP. OF (8)	1/4"-18 UNC AIR FITTING	3/4"-14 UNC AIR FITTING
300 in-lb 25 ft-lb	240 in-lb 20 ft-lb	240 in-lb 20 ft-lb

NOTE: SEE GUIDELINES FOR PROPER APPLICATION OF THIS PRODUCT

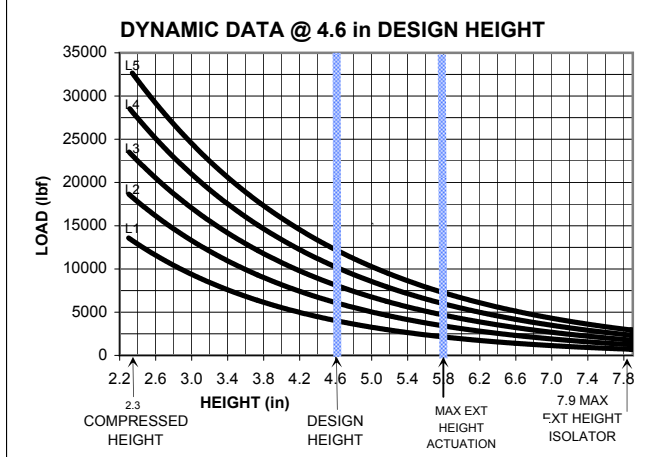
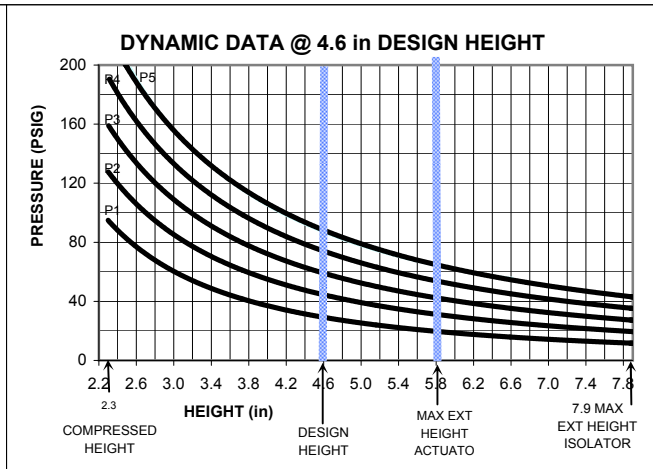
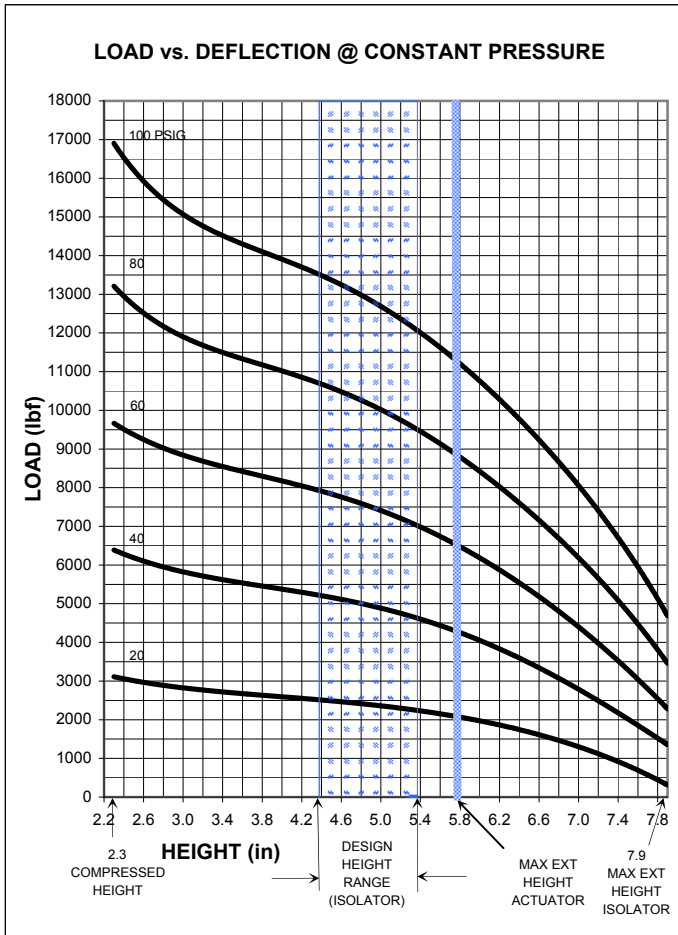

****NOTE: MAXIMUM INFLATION PRESSURE IS 100 PSIG. MAXIMUM JOUNCE PRESSURE IS 200 PSIG. IF YOUR APPLICATION WILL EXCEED THESE LIMITS, CONSULT A GOODYEAR ENGINEERED PRODUCTS AIR SPRINGS REPRESENTATIVE FOR APPLICATION ASSISTANCE.**

CONSTANT PRESSURE CHARACTERISTICS

Assembly Height (in)	Volume @ 100 PSIG (in ³)	Nominal Force (lb)				
		@ 20 PSIG	@ 40 PSIG	@ 60 PSIG	@ 80 PSIG	@ 100 PSIG
		7.9	1130	380	1450	2400
7.0	1035	1250	2700	4300	6000	7900
6.5	970	1700	3500	5400	7500	9600
6.0	904	2000	4100	6300	8500	10900
5.8	879	2000	4200	6500	8900	11300
5.4	822	2200	4600	7100	9600	12000
4.6	712	2500	5200	7900	10700	13400
4.4	679	2600	5300	8100	10900	13700
3.5	545	2800	5700	8700	11700	14700
3.0	469	2900	5900	9000	12100	15100
2.3	363	3100	6500	9600	13400	16700

DYNAMIC CHARACTERISTICS

Design Height (in)	Load (lb)	Pressure (PSIG)	Spring Rate (lb/in)	Natural Frequency	
				cpm	Hz
5.4	4000	33	1770	125	2.08
	6000	50	2470	121	2.02
	8000	66	3160	118	1.97
	10000	82	3885	117	1.95
4.6	4000	30	1930	130	2.17
	6000	45	2655	125	2.08
	8000	60	2340	122	2.03
	10000	74	4025	119	1.98
4.4	4000	30	2035	134	2.23
	6000	44	2710	126	2.10
	8000	59	3445	123	2.05
	10000	76	4170	121	2.02
4.4	12000	87	4890	120	2.00

The GOODYEAR (and Winged Foot Design) trademark is used by Veyance Technologies, Inc. under license from The Goodyear Tire & Rubber Company. Goodyear Engineered Products are manufactured and sourced exclusively by Veyance Technologies, Inc. or its affiliates. The following trademarks are licensed to Veyance Technologies, Inc. by The Goodyear Tire & Rubber Company, including Compass, Eagle Pd, Flexten, Gatorback and GY Metric. ©2008 Veyance Technologies, Inc. All Rights Reserved.



2B6-530

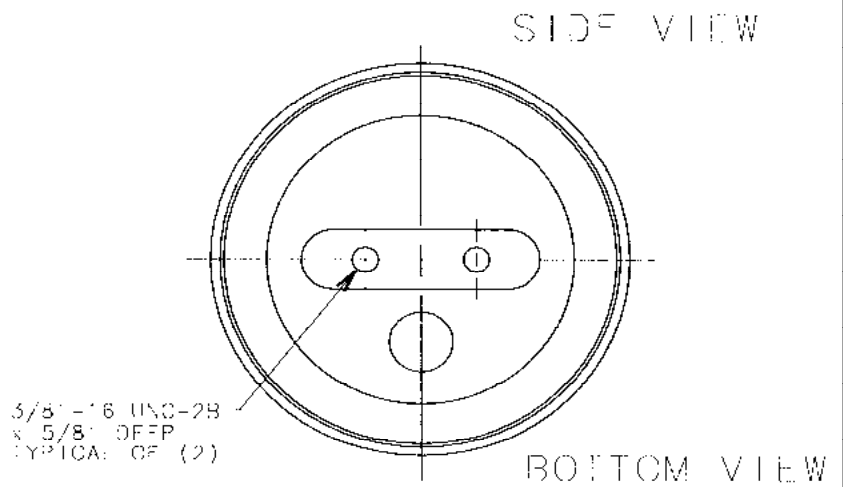
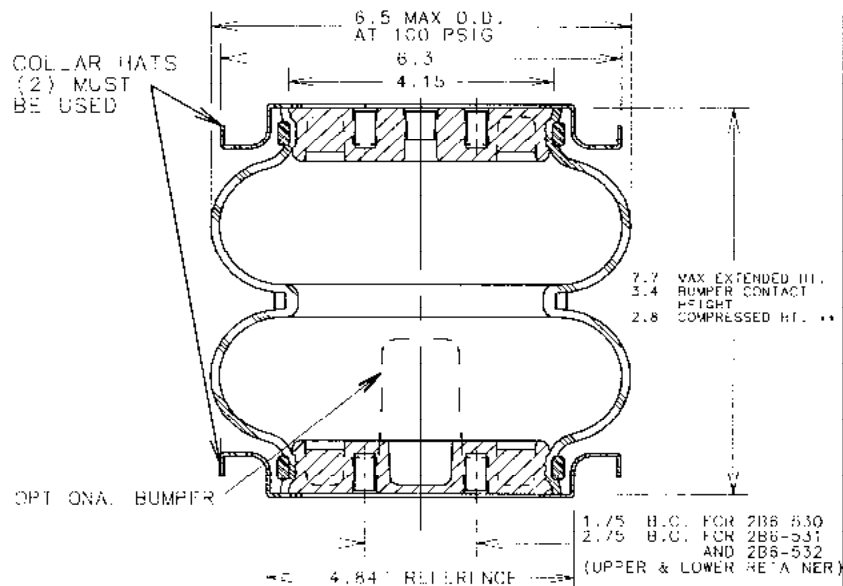
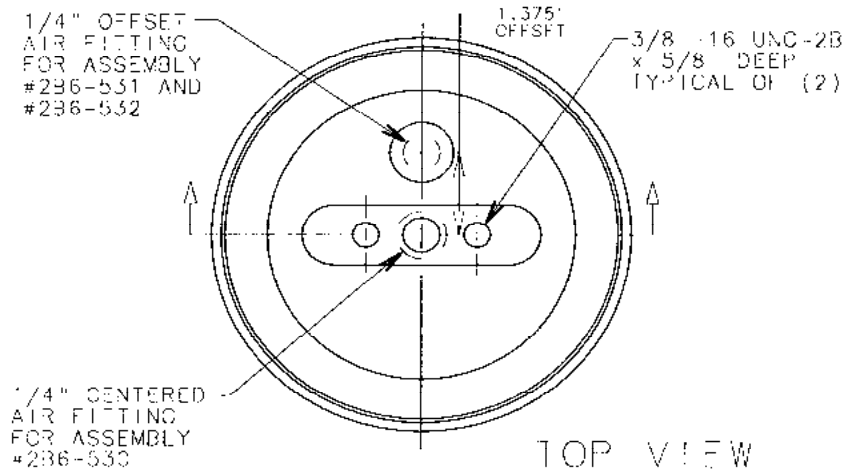

ASSEMBLY NUMBER	ELASTOMER	AIR FITTING	BUMPER INCLUDED
2B6-530	WINGPRENE®	1/4"-18 NPT CENTERED	NO
2B6-531	WINGPRENL®	1/4"-18 NPT OFFSET 1.375"	NO
2B6-532	WINGPRENF®	1/4"-18 NPT OFFSET 1.375"	YES

SPRING FEATURES:

- LOAD RANGE (ISOLATOR).....180-2000 lb
- DESIGN HEIGHT RANGE (ISOLATOR).....4.5-6.5 in
- USEABLE STROKE w/o BUMPER (ACTUATOR)***.4.5 in
- USEABLE STROKE WITH BUMPER (ACTUATOR)....4.3 in
- ASSEMBLY WEIGHT w/o BUMPER.....5.1 lb
- FORCE TO COMPRESS AT 0 PSIG (See Note **)
- NOMINAL FREE STANDING HT. AT 0 PSIG.....5.8 in

**NOTE: FORCE TO COMPRESS AT 0 PSI INTERNAL PRESSURE NO BUMPER IS:
 (30 LBS FORCE TO GO TO 3.4" HEIGHT)
 (60 LBS FORCE TO GO TO 3.2" HEIGHT)
 (190 LBS FORCE TO GO TO 3.0" HEIGHT)
 (410 LBS FORCE TO GO TO 2.8" HEIGHT)

*** BASED ON 3.2" COMPRESSED HEIGHT

RECOMMENDED MAX. TORQUE VALUES

3/8" -16 UNC BLIND TAP (TYP. OF (4))	1/4"-18 UNC AIR FITTING
240 in-lb 20 ft-lb	240 in-lb 20 ft-lb

NOTE: SEE GUIDELINES FOR PROPER APPLICATION OF THIS PRODUCT

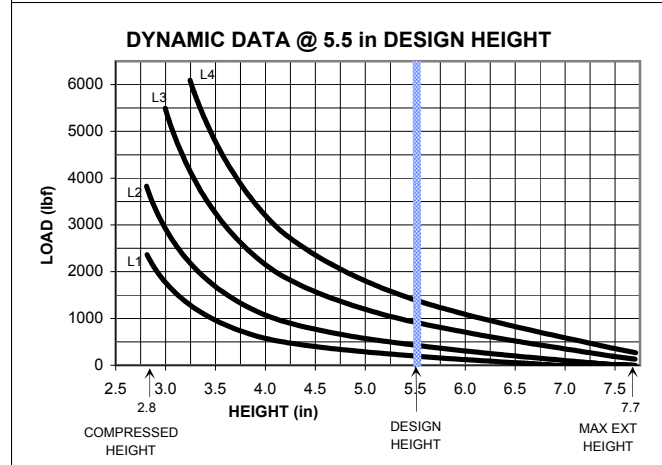
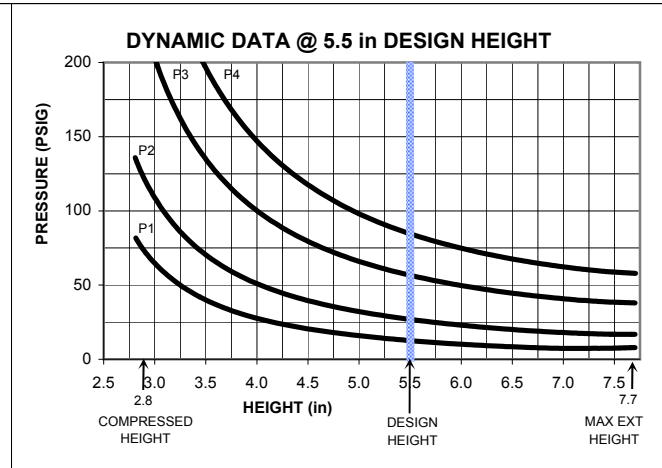
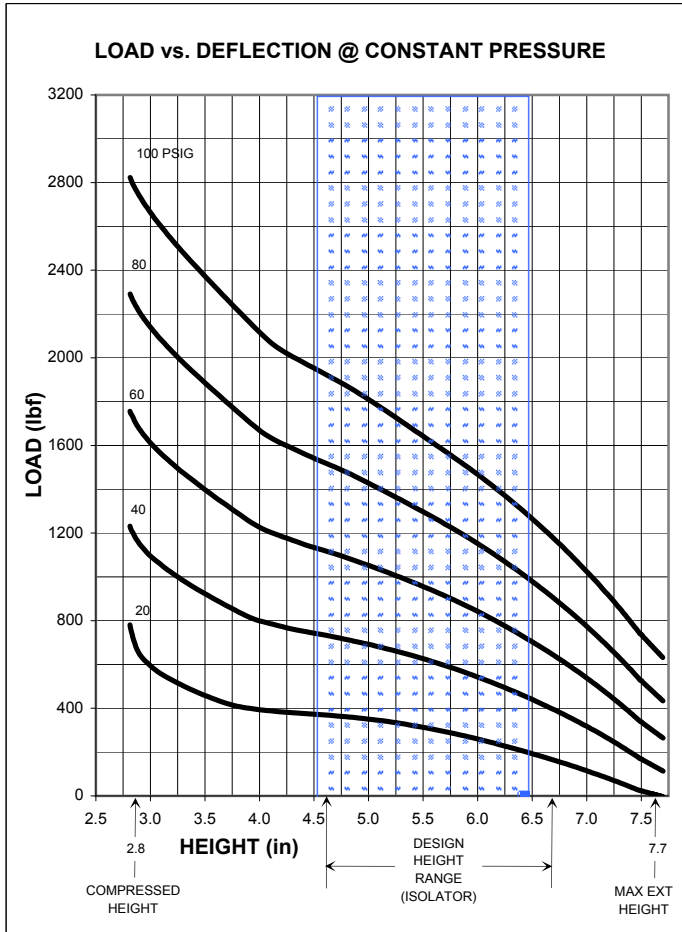

****NOTE: MAXIMUM INFLATION PRESSURE IS 100 PSIG. MAXIMUM JOUNCE PRESSURE IS 200 PSIG. IF YOUR APPLICATION WILL EXCEED THESE LIMITS, CONSULT A GOODYEAR ENGINEERED PRODUCTS AIR SPRINGS REPRESENTATIVE FOR APPLICATION ASSISTANCE.**

CONSTANT PRESSURE CHARACTERISTICS

Assembly Height (in)	Volume @ 100 PSIG (in ³)	Nominal Force (lb)				
		@ 20 PSIG	@ 40 PSIG	@ 60 PSIG	@ 80 PSIG	@ 100 PSIG
7.7	125	--	90	220	380	580
7.0	115	110	300	520	750	1000
6.5	108	180	420	680	1000	1300
6.0	100	250	520	800	1100	1500
5.5	91	300	620	900	1300	1600
5.0	82	340	680	1000	1400	1800
4.5	72	360	700	1100	1500	2000
4.0	62	380	750	1200	1700	2150
3.5	51	440	900	1350	1900	2400
2.8	36	750	1200	1700	2300	2800

DYNAMIC CHARACTERISTICS

Design Height (in)	Load (lb)	Pressure (PSIG)	Spring Rate (lb/in)	Natural Frequency	
				cpm	Hz
6.5	250	24	245	188	3.13
	500	44	370	160	2.67
	1000	80	600	146	2.43
5.5	250	15	185	162	2.70
	500	30	290	143	2.38
	1000	60	525	136	2.27
	1500	89	750	134	2.23
4.5	250	13	205	170	2.83
	500	26	350	157	2.62
	1000	52	620	147	2.45
	1500	77	865	143	2.38
	2000	100	1120	141	2.35

The GOODYEAR (and Winged Foot Design) trademark is used by Veyance Technologies, Inc. under license from The Goodyear Tire & Rubber Company. Goodyear Engineered Products are manufactured and sourced exclusively by Veyance Technologies, Inc. or its affiliates. The following trademarks are licensed to Veyance Technologies, Inc. by The Goodyear Tire & Rubber Company, including Compass, Eagle Pd, Flexten, Gatorback and GY Metric. ©2008 Veyance Technologies, Inc. All Rights Reserved.



2B6-535

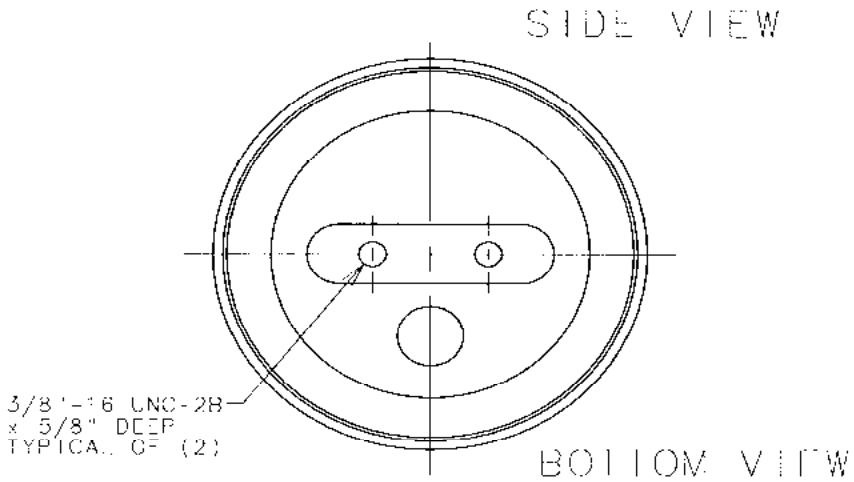
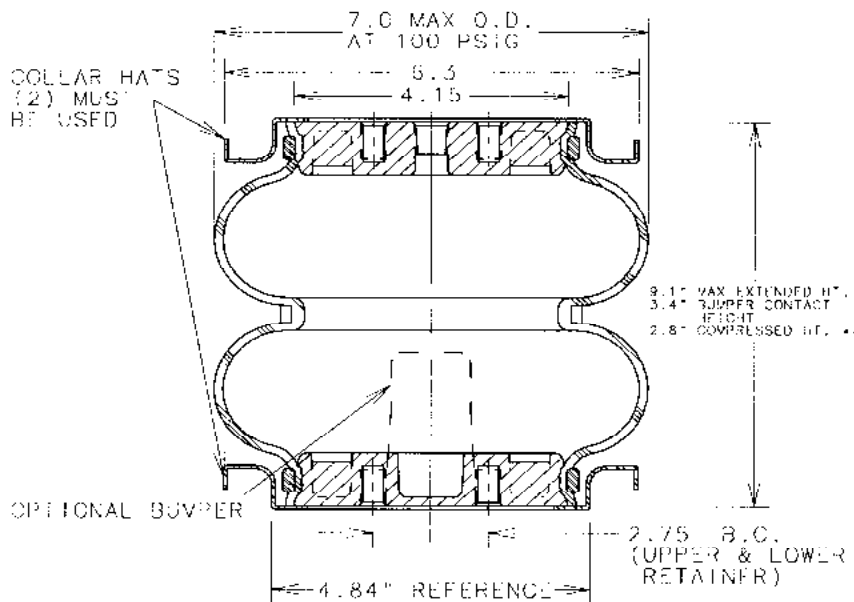
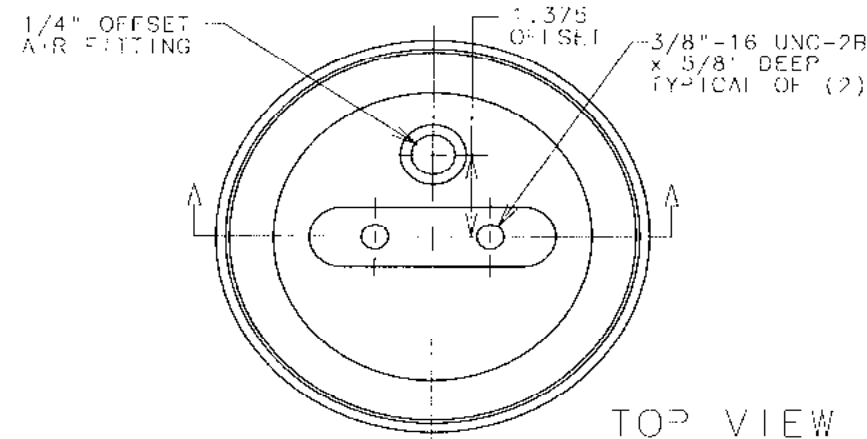

ASSEMBLY NUMBER	ELASTOMER	AIR FITTING	BUMPER INCLUDED
2B6-535	WINGPRENL [®]	1/4" - 18 NPT [®] OFFSET	NO
2B6-536	WINGPRENL [®]	1/4" - 18 NPT [®] OFFSET 1.375"	YES

SPRING FEATURES:

- LOAD RANGE (ISOLATOR).....300-2200 lb
- DESIGN HEIGHT RANGE (ISOLATOR).....5.0-7.0 in
- USEABLE STROKE w/o BUMPER (ACTUATOR)....5.9 in
- USEABLE STROKE WITH BUMPER (ACTUATOR)...5.7 in
- ASSEMBLY WEIGHT w/o BUMPER.....5.2 lb
- FORCE TO COMPRESS AT 0 PSIG (See Note **)
- NOMINAL FREE STANDING HT. AT 0 PSIG....7.1 in

**NOTE: FORCE TO COMPRESS AT 0 PSI: INTERNAL PRESSURE NO BUMPER: S:
 (120 LBS FORCE TO GO TO 3.4" HEIGHT)
 (120 LBS FORCE TO GO TO 3.2" HEIGHT)
 (180 LBS FORCE TO GO TO 3.0" HEIGHT)
 (450 LBS FORCE TO GO TO 2.8" HEIGHT)

*** BASED ON 3.2" COMPRESSED HEIGHT

RECOMMENDED MAX. TORQUE VALUES

3/8"-16 UNC BLIND TAP TYP. OF (4)	1/4"-18 UNC AIR FITTING
240 in-lb 20 ft-lb	240 in-lb 20 ft-lb

NOTE: SEE GUIDELINES FOR PROPER APPLICATION OF THIS PRODUCT

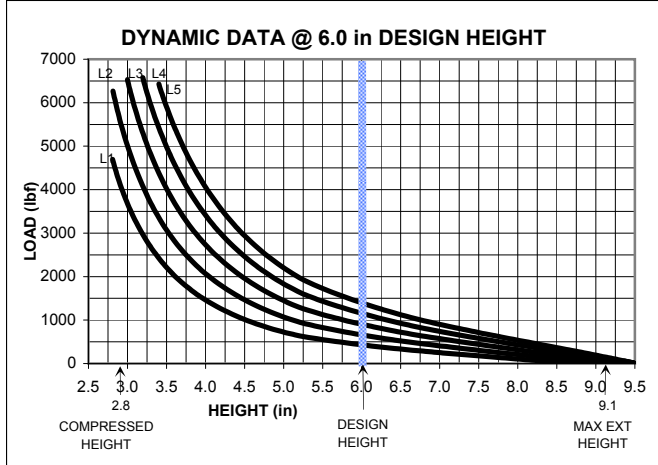
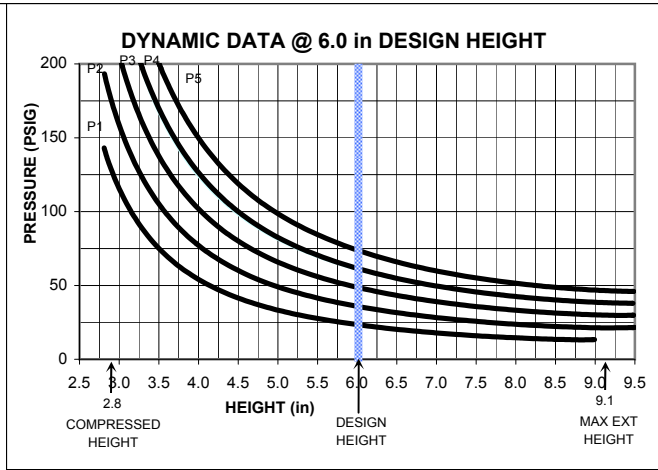
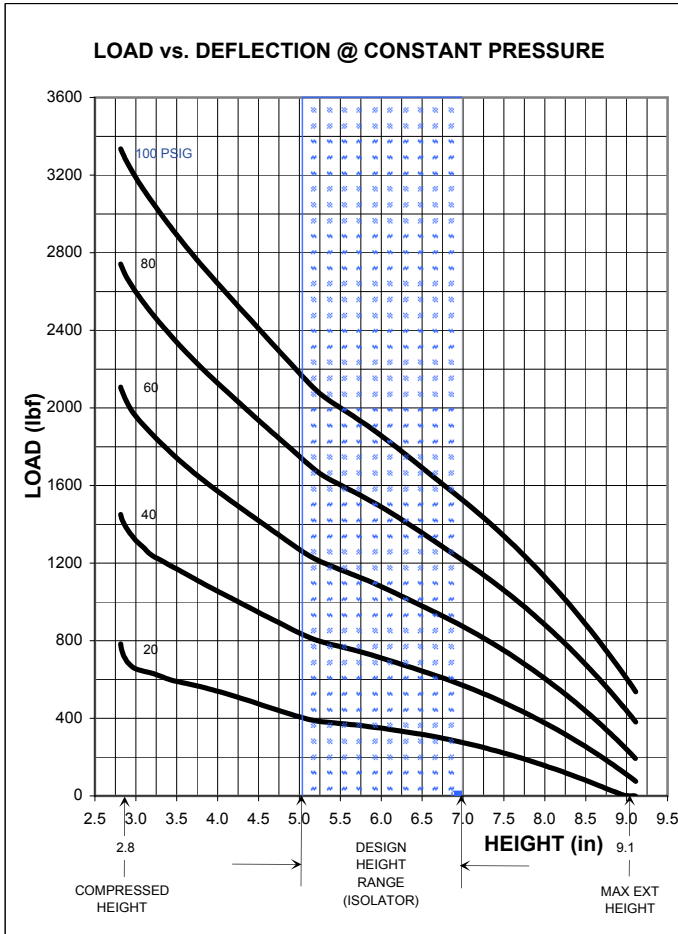

****NOTE: MAXIMUM INFLATION PRESSURE IS 100 PSIG. MAXIMUM JOUNCE PRESSURE IS 200 PSIG. IF YOUR APPLICATION WILL EXCEED THESE LIMITS, CONSULT A GOODYEAR ENGINEERED PRODUCTS AIR SPRINGS REPRESENTATIVE FOR APPLICATION ASSISTANCE.**

CONSTANT PRESSURE CHARACTERISTICS

Assembly Height (in)	Volume @ 100 PSIG (in ³)	Nominal Force (lb)				
		@ 20 PSIG	@ 40 PSIG	@ 60 PSIG	@ 80 PSIG	@ 100 PSIG
9.1	169	0	80	200	380	560
8.5	162	90	260	460	680	900
8.0	155	170	400	630	900	1150
7.5	147	240	500	750	1100	1400
7.0	138	300	580	900	1250	1500
6.0	119	380	750	1100	1500	1900
5.0	97	440	850	1300	1800	2200
4.5	85	520	1000	1450	2000	2500
3.5	59	680	1250	1800	2400	3000
2.8	38	750	1500	2100	2700	3300

DYNAMIC CHARACTERISTICS

Design Height (in)	Load (lb)	Pressure (PSIG)	Spring Rate (lb/in)	Natural Frequency	
				cpm	Hz
7.0	500	32	245	131	2.18
	750	47	335	126	2.10
	1000	63	440	125	2.08
	1250	78	530	123	2.05
6.0	1500	94	645	122	2.03
	500	26	250	132	2.20
	750	40	345	128	2.13
	1000	53	440	124	2.07
5.0	1250	65	530	122	2.03
	1500	77	625	121	2.02
	500	23	360	159	2.65
	750	34	475	149	2.48
	1000	45	595	145	2.42
5.0	1250	57	705	141	2.35
	1500	68	845	140	2.33

The GOODYEAR (and Winged Foot Design) trademark is used by Veyance Technologies, Inc. under license from The Goodyear Tire & Rubber Company. Goodyear Engineered Products are manufactured and sourced exclusively by Veyance Technologies, Inc. or its affiliates. The following trademarks are licensed to Veyance Technologies, Inc. by The Goodyear Tire & Rubber Company, including Compass, Eagle Pd, Flexten, Gatorback and GY Metric. ©2008 Veyance Technologies, Inc. All Rights Reserved.



2B7-540

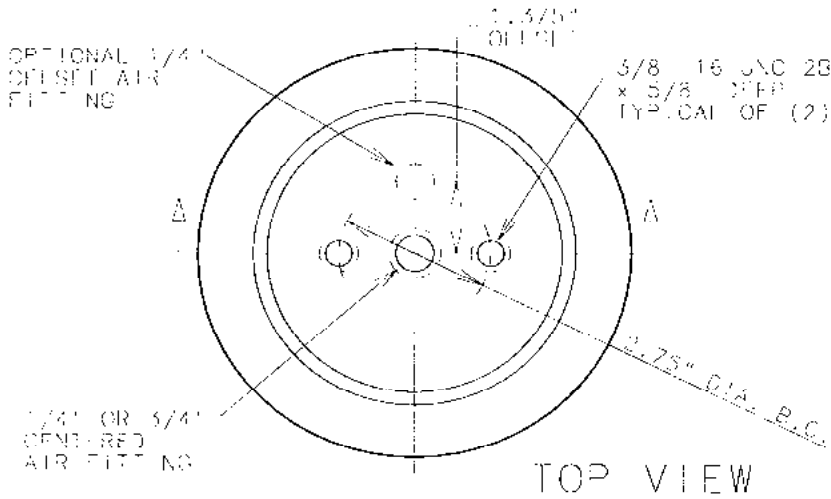

ASSEMBLY NUMBER	ELASTOMER	AIR FITTING	BUMPER SOLICITED
2B7-540	W NBRPNE [Ⓢ]	1/4"-18 NPTF CENTERED	NO
2B7-541	W NBRPNE [Ⓢ]	1/4"-18 NPTF OFFSET 1.3/32"	NO
2B7-542	W NBRPNE [Ⓢ]	1/4"-18 NPTF OFFSET 1.3/32"	YES
2B7-546	W NBRPNE [Ⓢ]	3/4"-14 NPTF CENTERED	NO

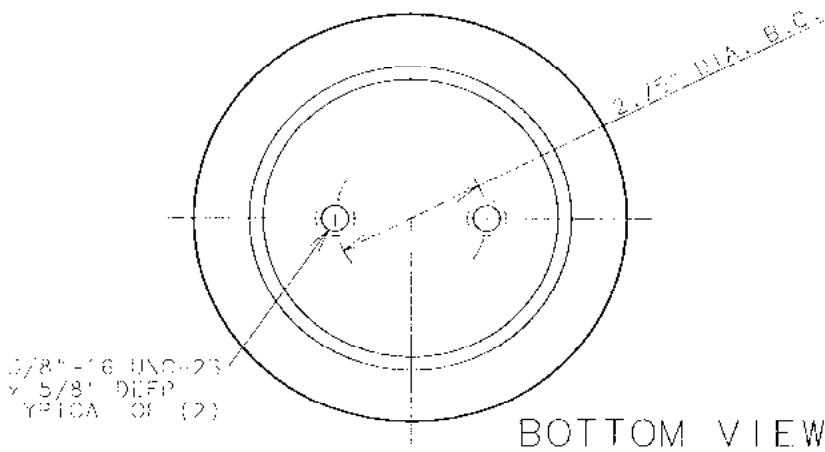
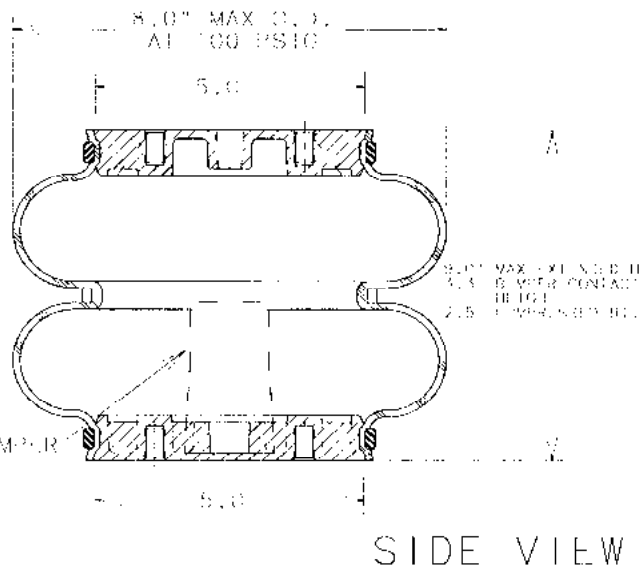

SPRING FEATURES:

- LOAD RANGE (ISOLATOR).....250-2500 lb
- DESIGN HEIGHT RANGE (ISOLATION).....6.0-8.0 in
- UNFAB. STROKE w/o BUMPER (ACTUATOR).....6.5 in
- USABLE STROKE w/ THE BUMPER (ACTUATOR).....7 in
- ASSEMBLY WEIGHT w/o BUMPER.....1.5 lb
- THRU TO COMPRESS AT 100 PSIG (APPROX).....10 lb
- NOMINAL FREE STANDING HEIGHT @ 0 PSIG.....5.7 in

RECOMMENDED MAX. TORQUE VALUES

3/8" -16 UNC 2B x 5/8" DEEP TYPICAL OF (2)	1/4" -18 UNC AIR FITTING	3/4" -14 UNC AIR FITTING
240 in-lb 20 ft-lb	270 in-lb 20 ft-lb	240 in-lb 20 ft-lb

NOTE: SEE SPECIFICATIONS FOR PROPER APPLICATION OF THIS PRODUCT

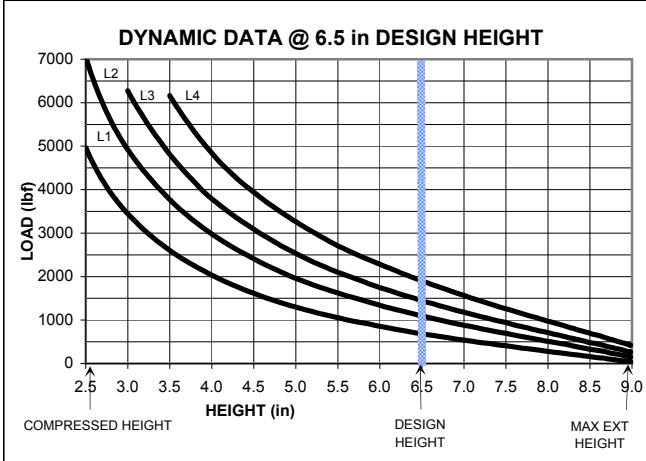
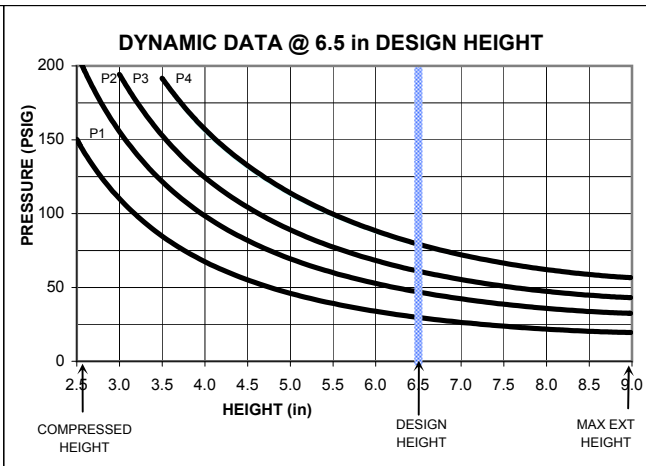
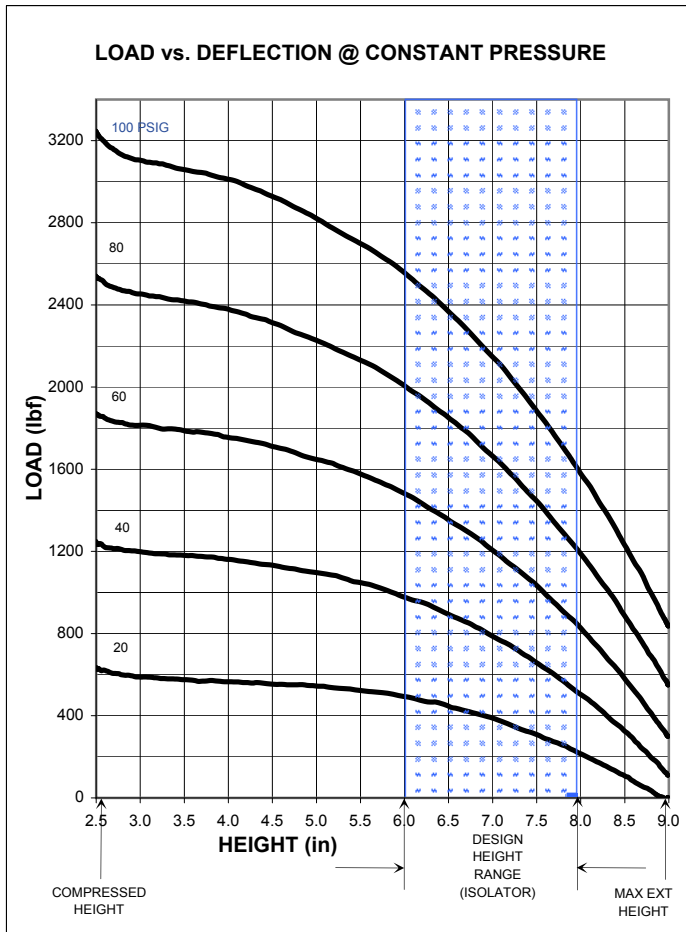

****NOTE: MAXIMUM INFLATION PRESSURE IS 100 PSIG. MAXIMUM JOUNCE PRESSURE IS 200 PSIG. IF YOUR APPLICATION WILL EXCEED THESE LIMITS, CONSULT A GOODYEAR ENGINEERED PRODUCTS AIR SPRINGS REPRESENTATIVE FOR APPLICATION ASSISTANCE.**

CONSTANT PRESSURE CHARACTERISTICS

Assembly Height (in)	Volume @ 100 PSIG (in ³)	Nominal Force (lb)				
		@ 20 PSIG	@ 40 PSIG	@ 60 PSIG	@ 80 PSIG	@ 100 PSIG
9.0	232	0	110	280	540	800
8.5	222	120	320	640	900	1250
8.0	214	230	500	800	1200	1600
7.0	195	380	800	1200	1700	2100
6.5	182	460	900	1350	1800	2300
6.0	151	500	950	1450	2000	2500
5.0	136	540	1100	1600	2200	2800
4.0	105	560	1150	1700	2400	3000
3.0	74	580	1200	1800	2400	3100
2.5	59	620	1200	1800	2500	3200

DYNAMIC CHARACTERISTICS

Design Height (in)	Load (lb)	Pressure (PSIG)	Spring Rate (lb/in)	Natural Frequency	
				cpm	Hz
8.0	730	48	450	147	2.45
	1150	72	655	142	2.37
	1500	92	800	137	2.28
6.5	730	31	335	126	2.10
	1150	49	480	122	2.03
	1500	63	595	118	1.97
6.0	1950	81	730	115	1.92
	730	30	325	125	2.08
	1150	46	475	121	2.02
6.0	1500	59	575	117	1.95
	1950	76	715	114	1.90

The GOODYEAR (and Winged Foot Design) trademark is used by Veyance Technologies, Inc. under license from The Goodyear Tire & Rubber Company. Goodyear Engineered Products are manufactured and sourced exclusively by Veyance Technologies, Inc. or its affiliates. The following trademarks are licensed to Veyance Technologies, Inc. by The Goodyear Tire & Rubber Company, including Compass, Eagle Pd, Flexten, Gatorback and GY Metric. ©2008 Veyance Technologies, Inc. All Rights Reserved.



2B8-550

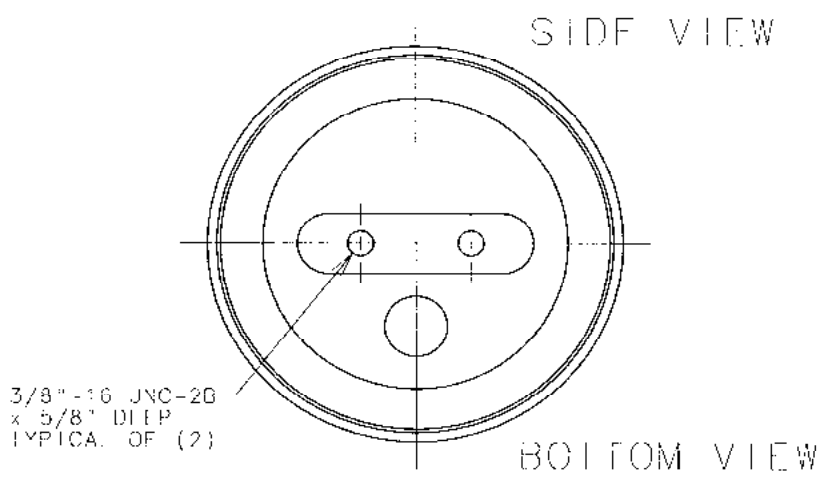
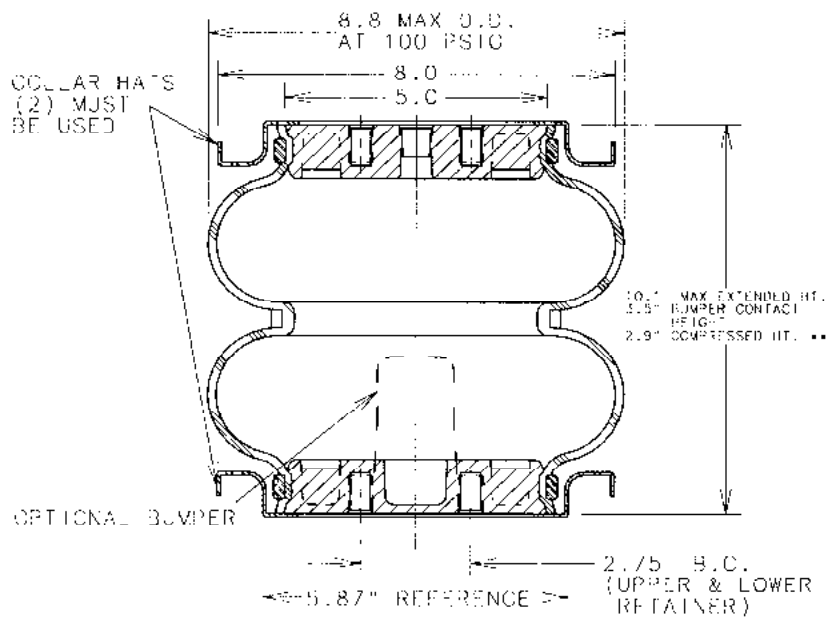
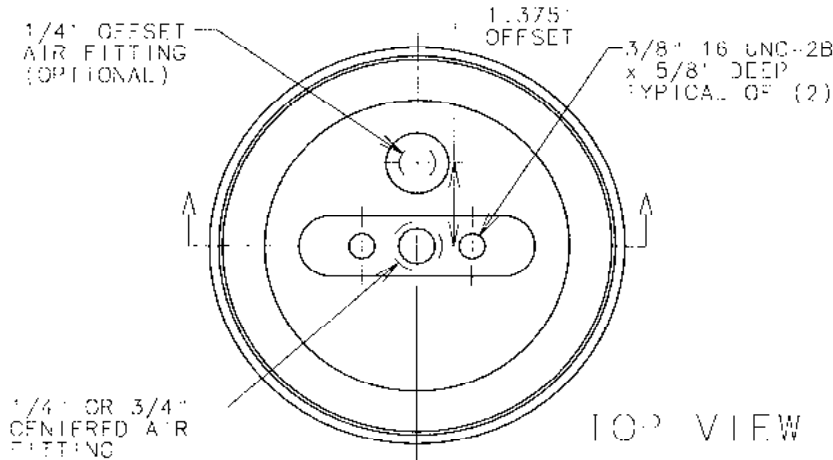

ASSEMBLY NUMBER	ELASTOMER	AIR FITTING	BUMPER INCLUDED
2B8-550	W.NOPRENE®	1/4"-18 NPTF CENTERED	NO
2B8-552	W.NOPRENE®	3/4"-14 NPTF CENTERED	NO
2B8-553	W.NOPRENE®	1/4"-18 NPTF OFFSET 1.375"	NO
2B8-554	W.NOPRENE®	1/4"-18 NPTF OFFSET 1.375"	YES

SPRING FEATURES:

- LOAD RANGE (ISOLATOR).....440-2700 lb
- DESIGN HEIGHT RANGE (ISOLATOR).....7.0-8.0 in
- USEABLE STROKE w/o BUMPER (ACTUATOR)***6.9 in
- USEABLE STROKE WITH BUMPER (ACTUATOR)....6.6 in
- ASSEMBLY WEIGHT w/o BUMPER.....7.7 lb
- FORCE TO COMPRESS AT 0 PSIG (See Note **)
- NOMINAL FREE STANDING HT. AT 0 PSIG.....8.8 in

** NOTE: FORCE TO COMPRESS AT 0 PSI INTERNAL PRESSURE NO BUMPER IS:
 (100 LBS FORCE TO GO TO 3.4" HEIGHT)
 (150 LBS FORCE TO GO TO 3.2" HEIGHT)
 (310 LBS FORCE TO GO TO 3.0" HEIGHT)
 (480 LBS FORCE TO GO TO 2.9" HEIGHT)

*** BASED ON 3.2" COMPRESSED HEIGHT

RECOMMENDED MAX. TORQUE VALUES

3/8"-16 UNC BLIND TAP TYP. OF (4)	1/4"-18 UNC AIR FITTING
240 in-lb 20 ft-lb	240 in-lb 20 ft-lb

NOTE: SEE GUIDELINES FOR PROPER APPLICATION OF THIS PRODUCT

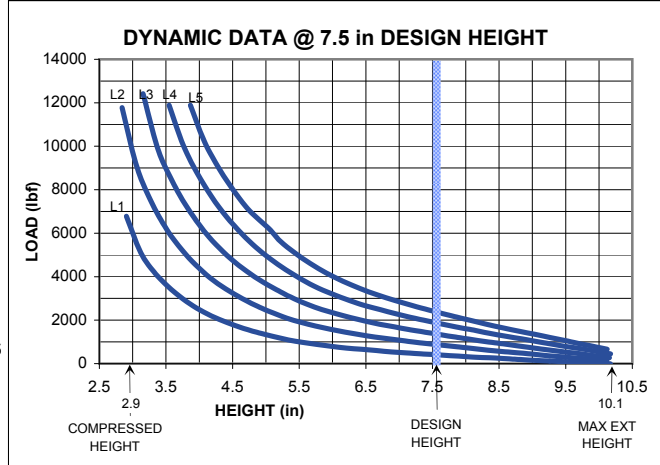
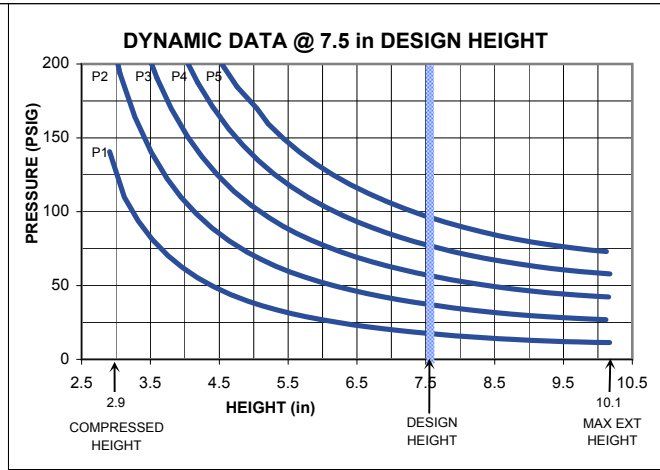
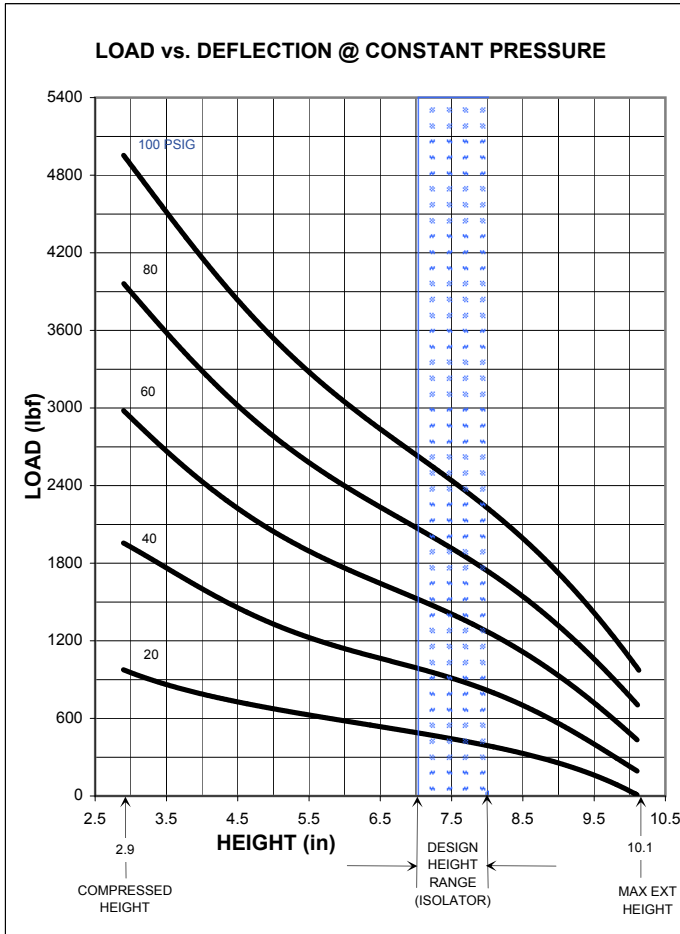

****NOTE: MAXIMUM INFLATION PRESSURE IS 100 PSIG. MAXIMUM JOUNCE PRESSURE IS 200 PSIG. IF YOUR APPLICATION WILL EXCEED THESE LIMITS, CONSULT A GOODYEAR ENGINEERED PRODUCTS AIR SPRINGS REPRESENTATIVE FOR APPLICATION ASSISTANCE.**

CONSTANT PRESSURE CHARACTERISTICS

Assembly Height (in)	Volume @ 100 PSIG (in ³)	Nominal Force (lb)				
		@ 20 PSIG	@ 40 PSIG	@ 60 PSIG	@ 80 PSIG	@ 100 PSIG
		10.1	295	30	180	450
9.0	274	300	600	1000	1350	1800
8.0	249	440	850	1300	1800	2300
7.5	235	500	950	1450	2000	2500
7.0	221	540	1050	1600	2100	2700
6.0	190	600	1200	1800	2400	3100
5.0	156	750	1400	2100	2900	3600
4.0	121	950	1700	2500	3400	4300
3.5	99	1000	1900	2800	3700	4600
2.9	75	1200	2100	3100	4100	5000

DYNAMIC CHARACTERISTICS

Design Height (in)	Load (lb)	Pressure (PSIG)	Spring Rate (lb/in)	Natural Frequency	
				cpm	Hz
8.0	500	22	230	128	2.13
	1000	44	400	120	2.00
	1500	65	560	115	1.92
	2000	87	710	112	1.87
7.5	500	20	220	125	2.08
	1000	41	385	117	1.95
	1500	60	535	112	1.87
	2000	79	680	110	1.83
	2500	99	820	108	1.80
7.0	500	19	220	125	2.08
	1000	38	380	116	1.93
	1500	57	530	112	1.87
	2000	74	675	109	1.82
	2500	92	820	108	1.80

The GOODYEAR (and Winged Foot Design) trademark is used by Veyance Technologies, Inc. under license from The Goodyear Tire & Rubber Company. Goodyear Engineered Products are manufactured and sourced exclusively by Veyance Technologies, Inc. or its affiliates. The following trademarks are licensed to Veyance Technologies, Inc. by The Goodyear Tire & Rubber Company, including Compass, Eagle Pd, Flexten, Gatorback and GY Metric. ©2008 Veyance Technologies, Inc. All Rights Reserved.



2B9-200

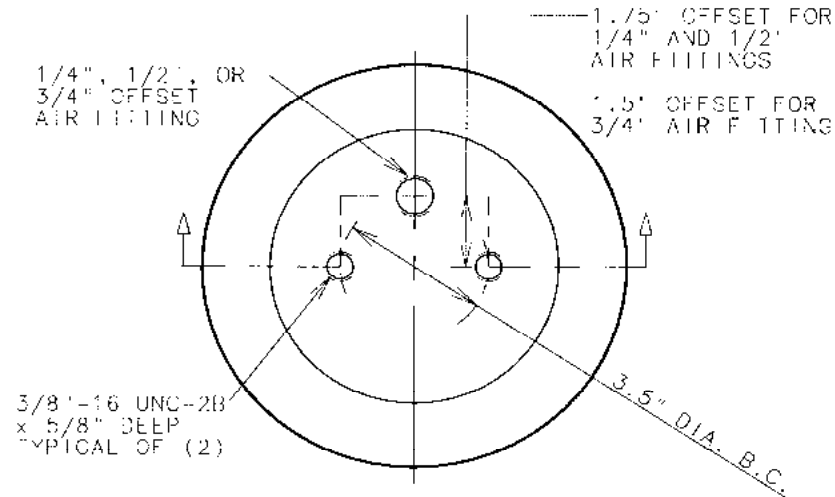

TOP VIEW

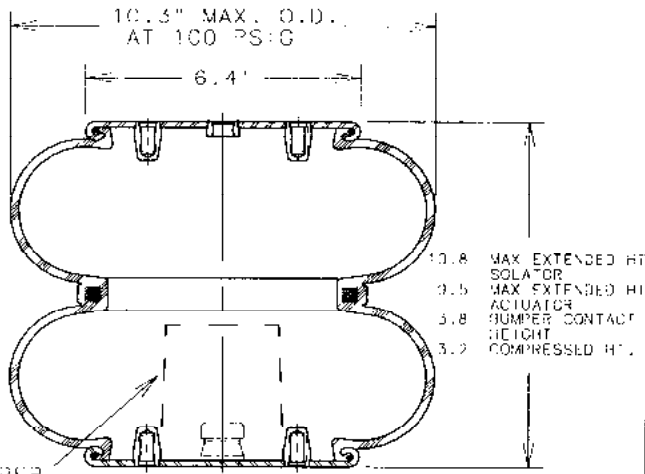

SIDE VIEW

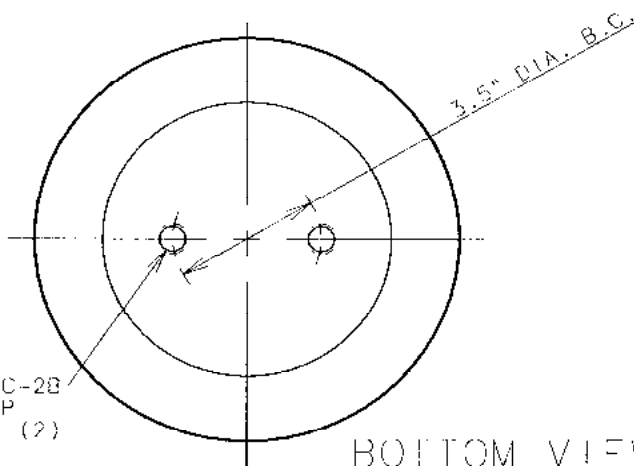

BOTTOM VIEW

ASSEMBLY NUMBER	ELASTOMER	AIR FITTING	BUMPER INCLUDED
2B9-200	NAT. RUBBER	1/4"-18 NPTF OFFSET 1.75"	NO
2B9-201	NAT. RUBBER	1/4"-18 NPTF OFFSET 1.75"	YES
2B9-204	NAT. RUBBER	1/2"-14 NPTF OFFSET 1.75"	NO
2B9-205	NAT. RUBBER	1/2"-14 NPTF OFFSET 1.75"	YES
2B9-216	NAT. RUBBER	3/4"-14 NPTF OFFSET 1.5"	NO
2B9-208	NAT. RUBBER	3/4"-14 NPTF OFFSET 1.5"	YES
S78923202 FLEXMEMBER ONLY	NAT. RUBBER	----	---

SPRING FEATURES:

- LOAD RANGE (ISOLATOR).....340-3700 lb
- DESIGN HEIGHT RANGE (ISOLATOR).....7.5-9.5 in
- USEABLE STROKE w/o BUMPER (ACTUATOR)....6.3 in
- USEABLE STROKE WITH BUMPER (ACTUATOR)....5.7 in
- ASSEMBLY WEIGHT.....7.5 lb
- FORCE TO COMPRESS AT 0 PSIG (APPROX.)....10 lb
- NOMINAL FREE STANDING HT. AT 0 PSIG.....5.1 in

RECOMMENDED MAX. TORQUE VALUES

3/8"-16 UNC BLIND TAP TYP. OF (4)	1/4"-18 UNC AIR FITTING	1/2"-14 UNC AIR FITTING	3/4"-14 UNC AIR FITTING
330 in-lb 25 ft-lb	240 in-lb 20 ft-lb	240 in-lb 20 ft-lb	240 in-lb 20 ft-lb

NOTE: SEE GUIDELINES FOR PROPER APPLICATION OF THIS PRODUCT

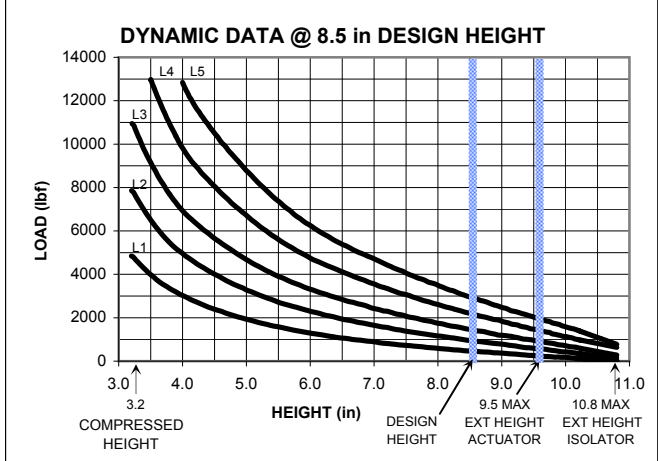
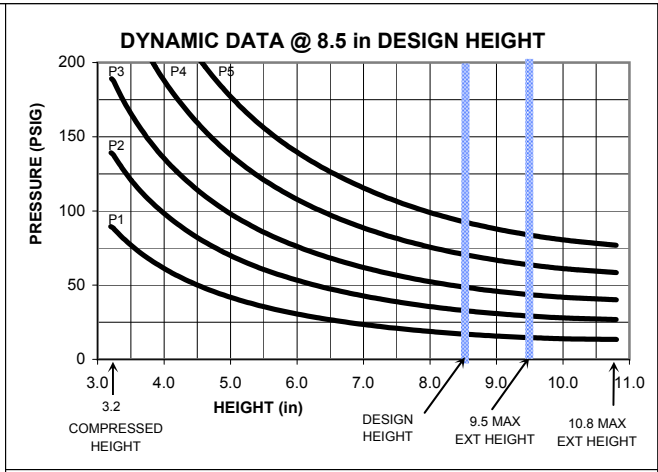
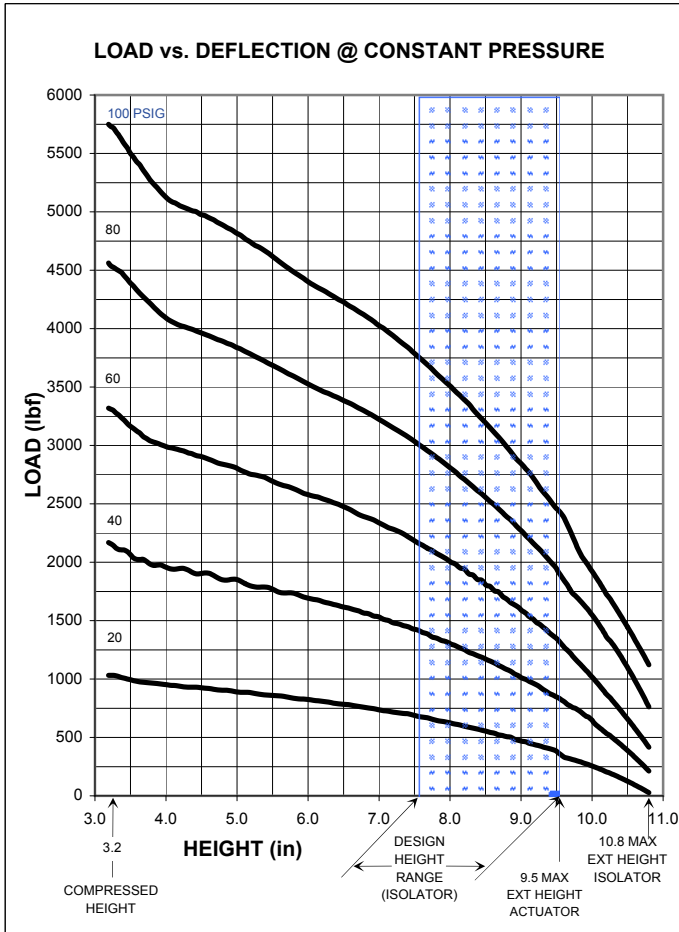

****NOTE: MAXIMUM INFLATION PRESSURE IS 100 PSIG. MAXIMUM JOUNCE PRESSURE IS 200 PSIG. IF YOUR APPLICATION WILL EXCEED THESE LIMITS, CONSULT A GOODYEAR ENGINEERED PRODUCTS AIR SPRINGS REPRESENTATIVE FOR APPLICATION ASSISTANCE.**

CONSTANT PRESSURE CHARACTERISTICS

Assembly Height (in)	Volume @ 100 PSIG (in ³)	Nominal Force (lb)				
		@ 20 PSIG	@ 40 PSIG	@ 60 PSIG	@ 80 PSIG	@ 100 PSIG
10.8	475	20	200	400	700	1100
10.0	442	250	620	1000	1500	1900
9.5	429	340	800	1300	1800	2300
8.5	399	540	1150	1700	2400	3100
7.5	363	660	1400	2100	2900	3700
6.5	321	750	1600	2400	3300	4200
5.5	274	850	1700	2600	3600	4500
4.5	223	900	1900	2800	3900	4900
3.5	169	950	2000	3100	4300	5400
3.2	155	1000	2100	3300	4500	5700

DYNAMIC CHARACTERISTICS

Design Height (in)	Load (lb)	Pressure (PSIG)	Spring Rate (lb/in)	Natural Frequency	
				cpm	Hz
9.5	500	24	320	150	2.50
	1000	45	480	130	2.17
	1500	64	705	129	2.15
	2250	90	980	124	2.07
8.5	500	18	255	133	2.22
	1000	34	400	119	1.98
	1500	50	570	116	1.93
	2250	72	755	110	1.83
	3000	94	1010	109	1.82
7.5	500	15	230	127	2.12
	1000	29	395	117	1.95
	1500	43	540	113	1.88
	2250	62	750	109	1.82
	3000	81	950	106	1.77

The GOODYEAR (and Winged Foot Design) trademark is used by Veyance Technologies, Inc. under license from The Goodyear Tire & Rubber Company. Goodyear Engineered Products are manufactured and sourced exclusively by Veyance Technologies, Inc. or its affiliates. The following trademarks are licensed to Veyance Technologies, Inc. by The Goodyear Tire & Rubber Company, including Compass, Eagle Pd, Flexten, Gatorback and GY Metric. ©2008 Veyance Technologies, Inc. All Rights Reserved.



2B9-250

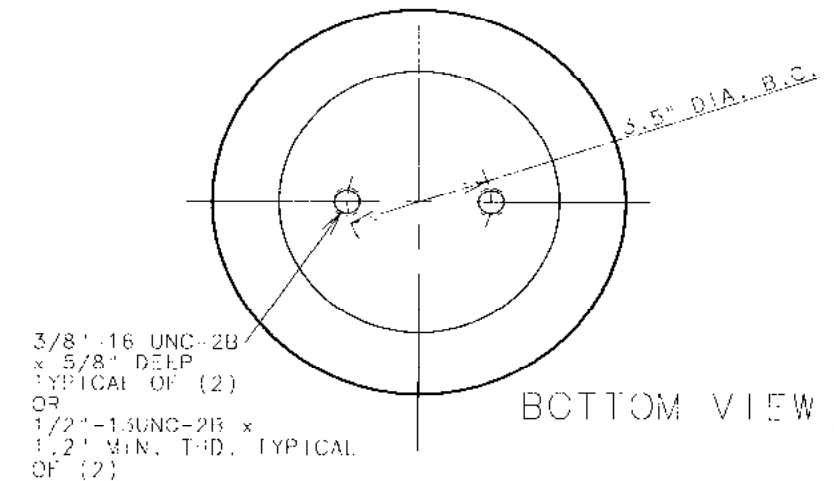
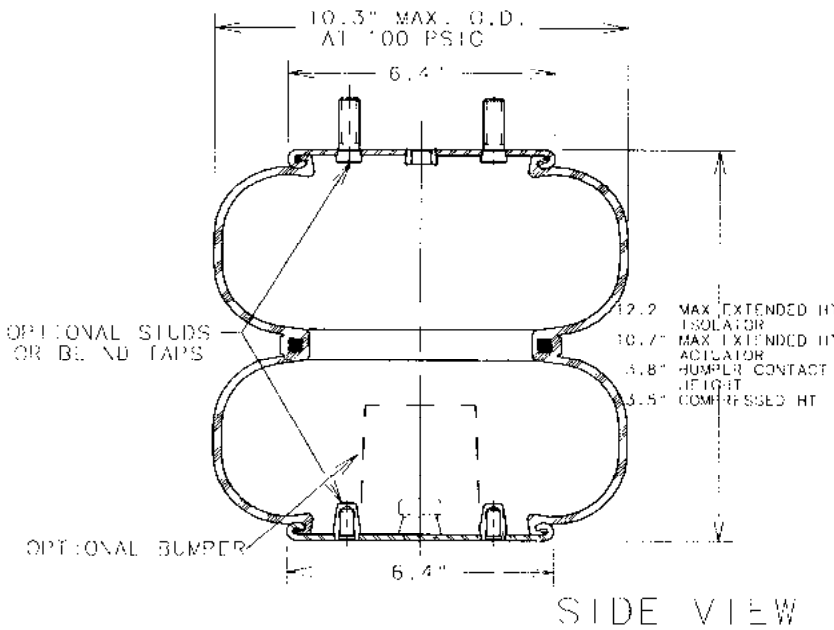
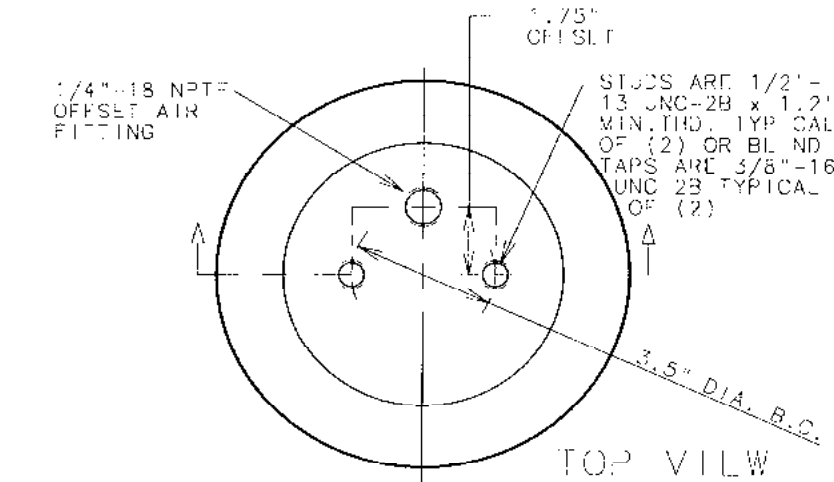

ASSEMBLY NUMBER	AIR FITTING	ATTACHMENTS		BUMPER INCLUDED
		TOP	BOTTOM	
2B9-250	1/4"-18 NPTF OFFSET 1.75"	STUDS	BLD TAPS	NO
2B9-251	1/4"-18 NPTF OFFSET 1.75"	STUDS	BLD TAPS	YES
2B9-255	1/4"-18 NPTF OFFSET 1.75" WITH UPPER BEAD PLATE ROTATED 90°	STUDS	BLD TAPS	YES
2B9-256	1/4"-18 NPTF OFFSET 1.75"	BLD TAPS	BLD TAPS	YES
2B9-258	1/4"-18 NPTF OFFSET 1.75"	BLD TAPS	BLD TAPS	NO
2B9-263	1/2"-14 NPTF OFFSET 1.75"	BLD TAPS	BLD TAPS	NO
2B9-275	3/4"-14 NPTF OFFSET 1.50"	BLD TAPS	BLD TAPS	NO

578923206 FLEX MEMBER ONLY
PLASTOMER-NATURAL RUBBER FOR ALL ABOVE

SPRING FEATURES:

- LOAD RANGE (ISOLATOR).....540-3900 lb
- DEFLECTION HEIGHT RANGE (ISOLATOR).....8.0-10.0 in
- USABLE STROKE w/o BUMPER (ACTUATOR)....7.2 in
- USABLE STROKE WITH BUMPER (ACTUATOR)....6.9 in
- ASSEMBLY WEIGHT.....8.7 lb
- FORCE TO COMPRESS AT 0 PSIG (APPROX.)...150 lb
- NOMINAL FREE STANDING HT. AT 0 PSIG....7.3 in

RECOMMENDED MAX. TORQUE VALUES

3/8"-16 UNC BLIND TAP TYP. OF (2)	1/4"-18 UNC AIR FITTING	1/2"-13 UNC TOP STUD TYP. OF (2)
300 in-lb 25 ft-lb	240 in-lb 20 ft-lb	300 in-lb 25 ft-lb

NOTE: SEE GUIDELINES FOR PROPER APPLICATION OF THIS PRODUCT

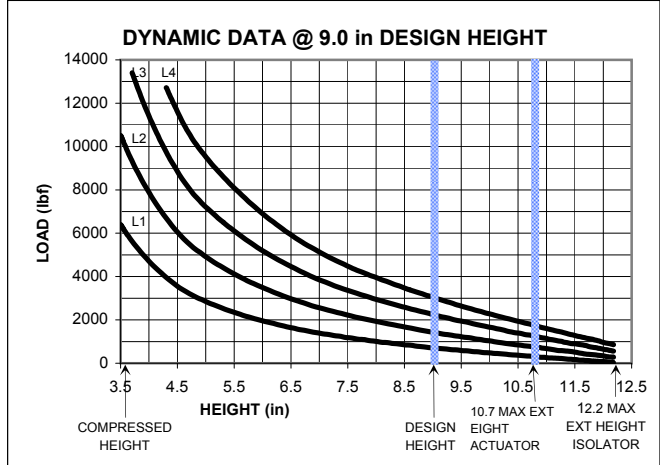
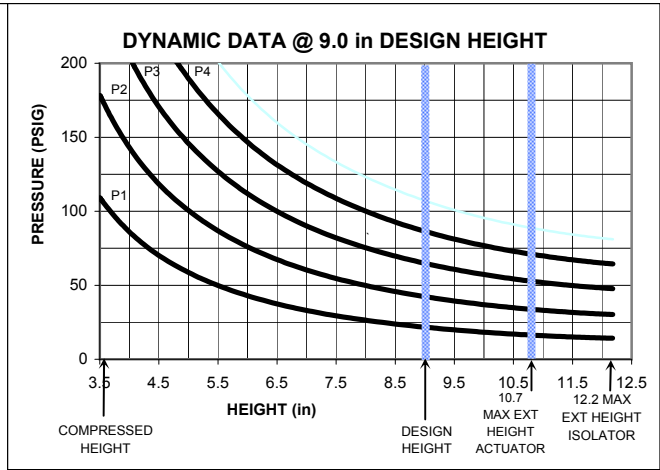
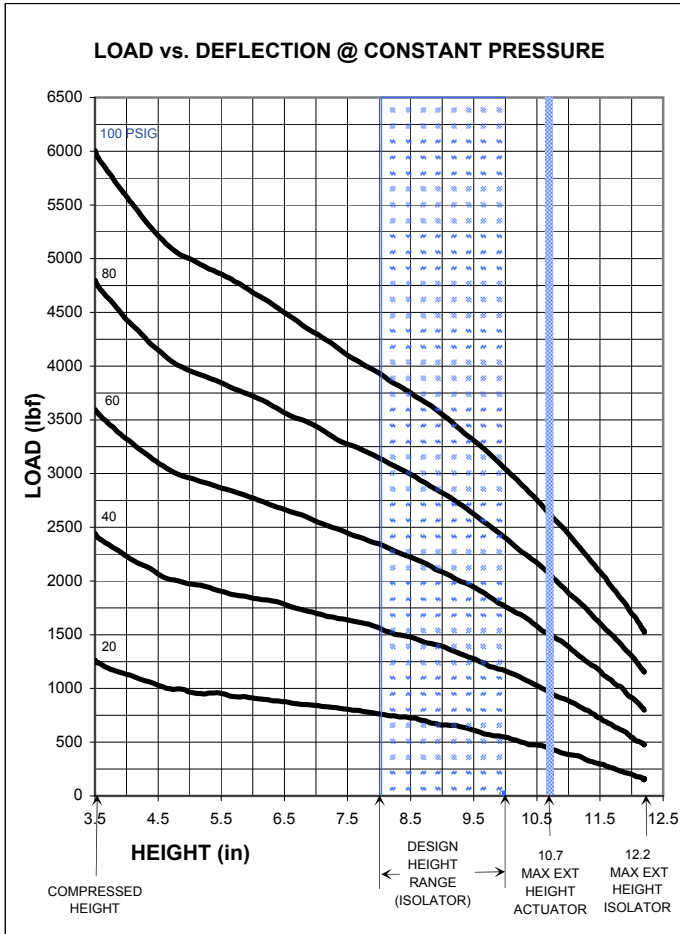

****NOTE: MAXIMUM INFLATION PRESSURE IS 100 PSIG. MAXIMUM JOUNCE PRESSURE IS 200 PSIG. IF YOUR APPLICATION WILL EXCEED THESE LIMITS, CONSULT A GOODYEAR ENGINEERED PRODUCTS AIR SPRINGS REPRESENTATIVE FOR APPLICATION ASSISTANCE.**

CONSTANT PRESSURE CHARACTERISTICS

Assembly Height (in)	Volume @ 100 PSIG (in ³)	Nominal Force (lb)				
		@ 20 PSIG	@ 40 PSIG	@ 60 PSIG	@ 80 PSIG	@ 100 PSIG
		12.2	500	120	440	800
11.5	487	280	700	1100	1500	2000
10.7	467	410	900	1400	1900	2500
10.0	449	540	1150	1700	2300	3000
9.0	418	640	1350	2000	2800	3500
8.0	382	750	1500	2300	3100	3800
7.5	363	800	1600	2400	3200	4000
6.5	320	850	1700	2600	3500	4400
5.5	273	900	1800	2800	3800	4800
4.5	221	1000	2000	3000	4100	5100
3.5	163	1250	2400	3600	4700	6000

DYNAMIC CHARACTERISTICS

Design Height (in)	Load (lb)	Pressure (PSIG)	Spring Rate (lb/in)	Natural Frequency	
				cpm	Hz
10.0	750	26	285	115	1.92
	1500	51	515	110	1.83
	2300	76	695	103	1.72
	3100	99	930	103	1.72
9.0	750	22	255	109	1.82
	1500	43	405	98	1.63
	2300	66	670	101	1.68
	3100	87	885	100	1.67
8.0	750	18	185	93	1.55
	1500	38	450	103	1.72
	2300	58	635	99	1.65
	3100	79	855	98	1.63
	3900	98	1025	96	1.60

The GOODYEAR (and Winged Foot Design) trademark is used by Veyance Technologies, Inc. under license from The Goodyear Tire & Rubber Company. Goodyear Engineered Products are manufactured and sourced exclusively by Veyance Technologies, Inc. or its affiliates. The following trademarks are licensed to Veyance Technologies, Inc. by The Goodyear Tire & Rubber Company, including Compass, Eagle Pd, Flexten, Gatorback and GY Metric. ©2008 Veyance Technologies, Inc. All Rights Reserved.



2B12-425

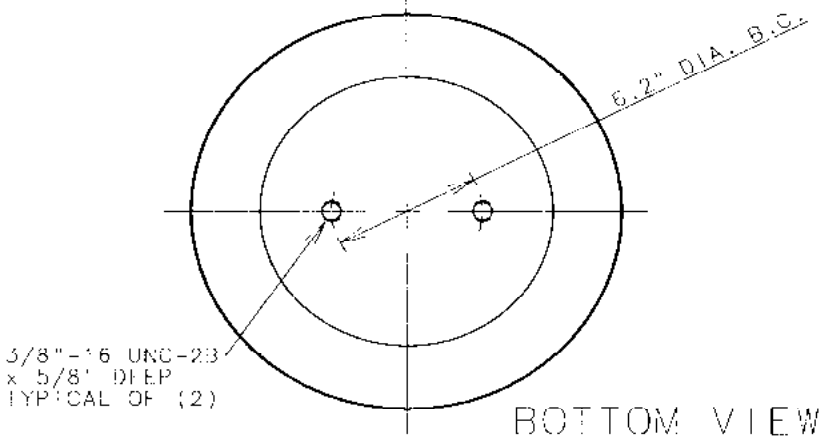
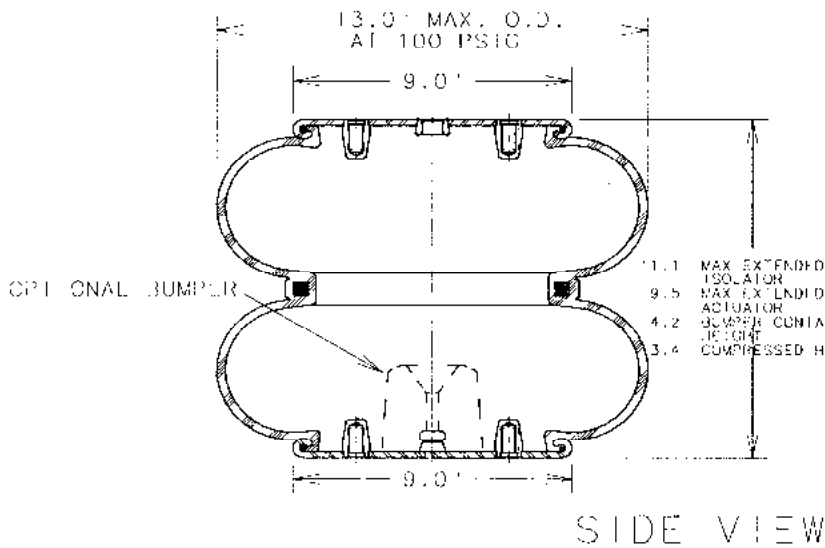
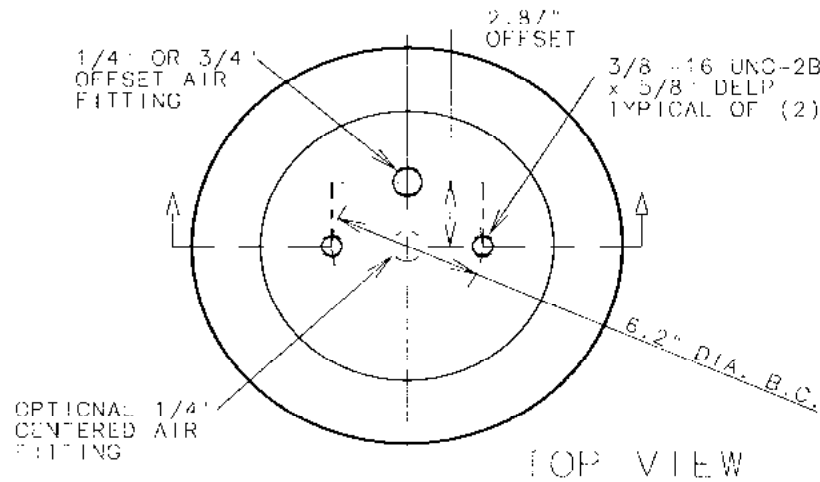

ASSEMBLY NUMBER	ELASTOMER	AIR FITTING	BUMPER INCLUDED
2B12-425	NAT. RUBBER	1/4"-18 NPTF OFFSET 2.87"	NO
2B12-429	NAT. RUBBER	3/4"-14 NPTF OFFSET 2.87"	NO
2B12-309	NAT. RUBBER	1/4"-18 NPTF OFFSET 2.87"	YES
2B12-318	NAT. RUBBER	3/4"-14 NPTF OFFSET 2.87"	YES
2B12-437	NAT. RUBBER	1/4"-18 NPTF CENTERED	NO
578923329 FLXMI-VIBR ONLY	NAT. RUBBER	----	----

SPRING FEATURES:

- LOAD RANGE (ISOLATOR).....900-7200 lb
- DESIGN HEIGHT RANGE (ISOLATOR).....7.5-9.5 in
- USEABLE STROKE w/o BUMPER (ACTUATOR)....6.1 in
- USEABLE STROKE WITH BUMPER (ACTUATOR)....5.3 in
- ASSEMBLY WEIGHT.....12.4 lb
- FORCE TO COMPRESS AT 0 PSIG (APPROX.)....50 lb
- NOMINAL FREE STANDING HT. AT 0 PSIG.....5.8 in

RECOMMENDED MAX. TORQUE VALUES

3/8"-16 UNC BLIND TAP TYP. OF (4)	1/4"-18 UNC AIR FITTING	3/4"-14 UNC AIR FITTING
500 in-lb 25 ft-lb	240 in-lb 20 ft-lb	240 in-lb 20 ft-lb

NOTE: SEE GUIDELINES FOR PROPER APPLICATION OF THIS PRODUCT

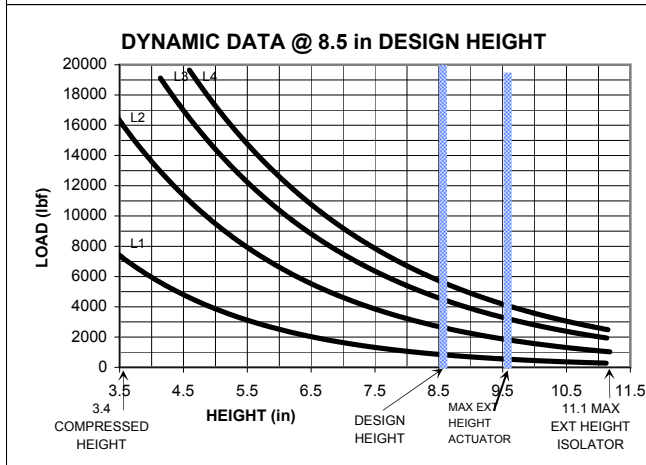
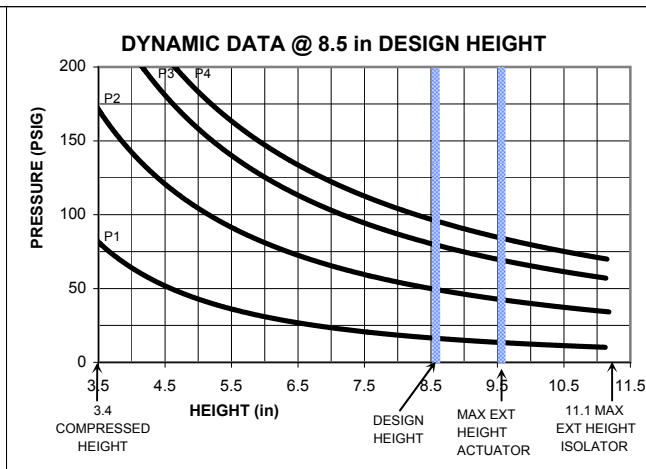
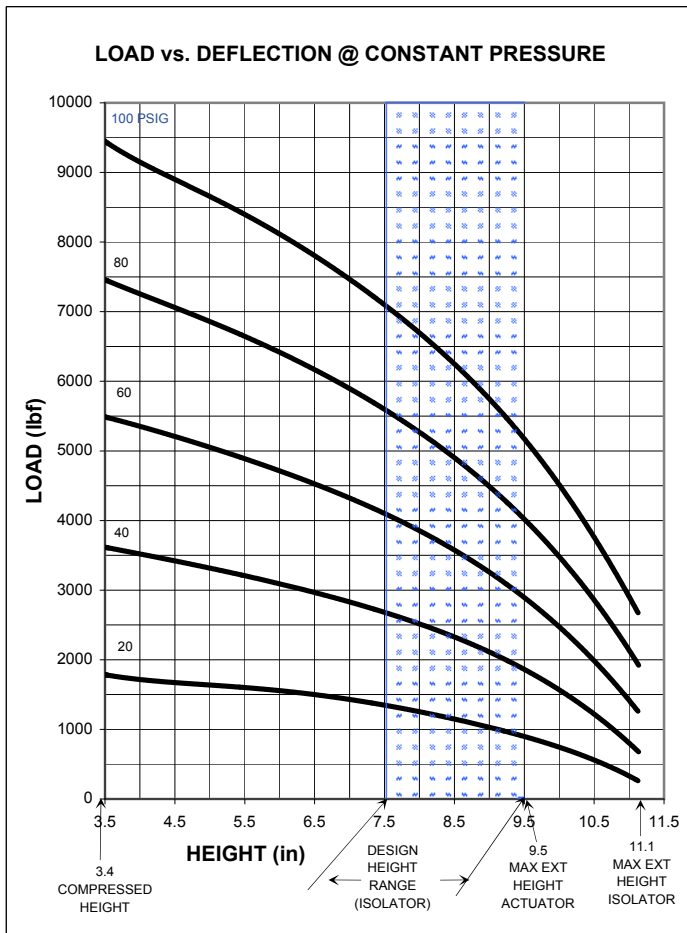

****NOTE: MAXIMUM INFLATION PRESSURE IS 100 PSIG. MAXIMUM JOUNCE PRESSURE IS 200 PSIG. IF YOUR APPLICATION WILL EXCEED THESE LIMITS, CONSULT A GOODYEAR ENGINEERED PRODUCTS AIR SPRINGS REPRESENTATIVE FOR APPLICATION ASSISTANCE.**

CONSTANT PRESSURE CHARACTERISTICS

Assembly Height (in)	Volume @ 100 PSIG (in ³)	Nominal Force (lb)				
		@ 20 PSIG	@ 40 PSIG	@ 60 PSIG	@ 80 PSIG	@ 100 PSIG
11.1	821	240	660	1200	1900	2700
10.5	779	580	1200	2000	2900	3800
9.5	751	900	1900	2900	4000	5200
9.0	717	1000	2200	3300	4500	5800
8.5	684	1150	2300	3600	4900	6300
7.5	612	1350	2700	4100	5600	7200
6.5	536	1500	3100	4500	6200	7900
5.5	463	1600	3200	4900	6700	8400
4.5	377	1700	3400	5200	7100	9000
3.5	285	1700	3500	5500	7400	9400
3.4	277	1600	3400	5500	7400	9400

DYNAMIC CHARACTERISTICS

Design Height (in)	Load (lb)	Pressure (PSIG)	Spring Rate (lb/in)	Natural Frequency	
				cpm	Hz
9.5	1000	20	420	123	2.05
	3000	59	1095	114	1.90
	5000	95	1720	110	1.83
8.5	1000	17	395	118	1.97
	3000	49	965	106	1.77
	5000	79	1490	103	1.72
7.5	6000	95	1760	102	1.70
	1000	15	415	121	2.02
	3000	43	940	106	1.77
	5000	72	1480	102	1.70
7.5	6000	85	1735	101	1.68
	7000	99	1985	100	1.67

The GOODYEAR (and Winged Foot Design) trademark is used by Veyance Technologies, Inc. under license from The Goodyear Tire & Rubber Company. Goodyear Engineered Products are manufactured and sourced exclusively by Veyance Technologies, Inc. or its affiliates. The following trademarks are licensed to Veyance Technologies, Inc. by The Goodyear Tire & Rubber Company, including Compass, Eagle Pd, Flexten, Gatorback and GY Metric. ©2008 Veyance Technologies, Inc. All Rights Reserved.



2B12-440

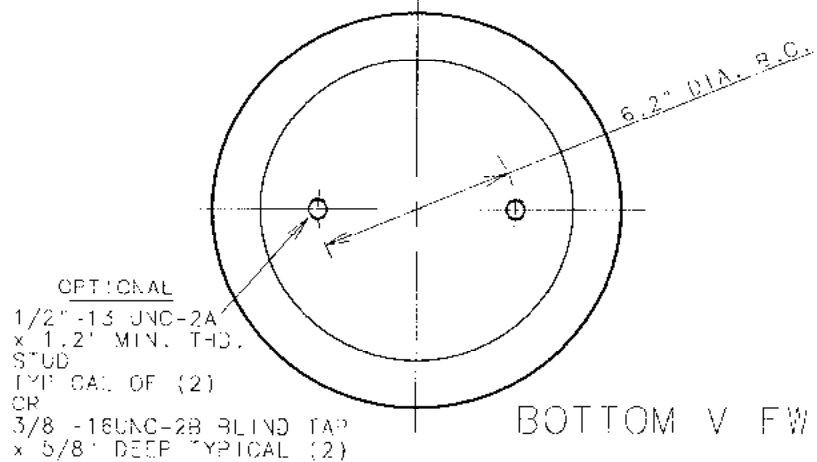
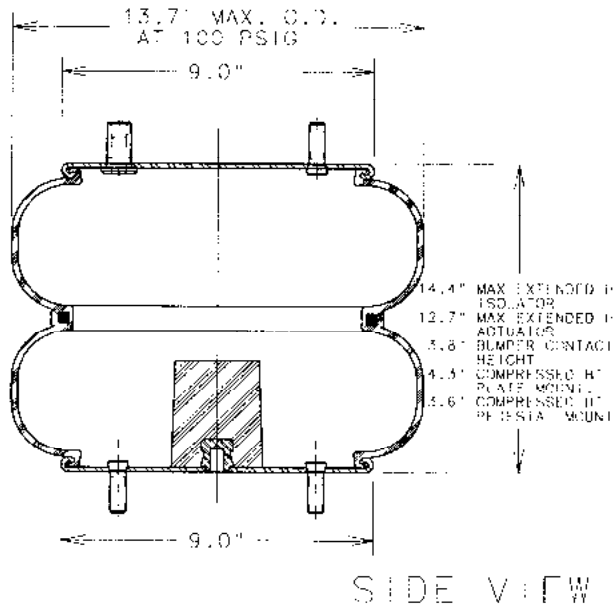
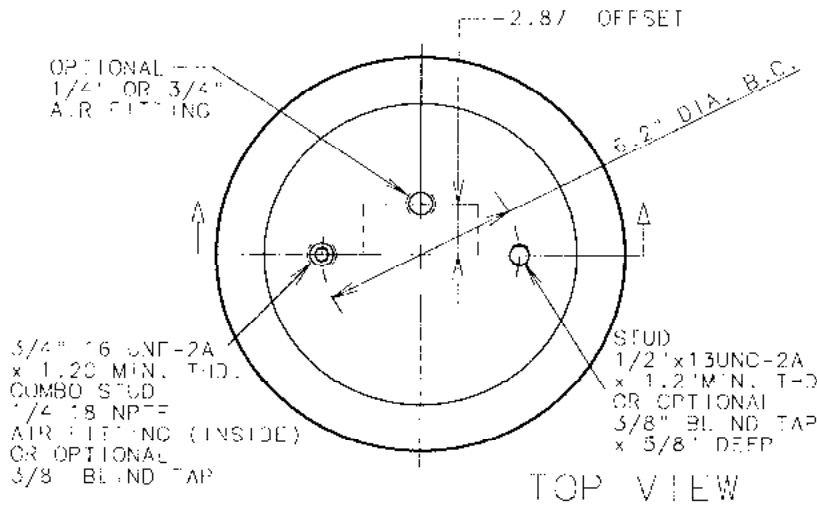

		ATTACHMENTS		
ASSEMBLY NUMBER	AIR FITTING	TOP	BOTTOM	BUMPER INCLUDED
2B12-416	1/4" -18 NPTF OFFSET 2.87"	BLIND TAPS	BLIND TAPS	NO
2B12-419	1/4" -18 NPTF OFFSET 1.75"	BLIND TAPS	BLIND TAPS	NO
2B12-440	1/4" -18 NPTF COMBO STUD (INSIDE)	STUDS ONE 1/2" x 13UNC x 1.2" MIN THD OR COMBO STUD 3/4" x 1.20 MIN THD	STUDS TWO 1/2" -13UNC x 1.2" MIN THD	YES
578825315 ELFX MEMBER ONLY				
ELASTOMER - NATURAL RUBBER FOR ALL ABOVE				

SPRING FEATURES:

- LOAD RANGE (ISOLATOR).....1300-8100 lb
- DESIGN HEIGHT RANGE (ISOLATOR).....7.5-9.5 in
- USABLE STROKE (ACTUATOR)(PLATE MOUNT).....6.4 in
- USABLE STROKE (ACTUATOR)(PEDESTAL MOUNT).....9.7 in
- ASSEMBLY WEIGHT.....14.0 lb
- ORDER TO COMPRESS AT 0 PSIG (APPROX).....120 lb
- NOMINAL FREE STANDING HT. AT 0 PSIG.....8.3 in

OTHER OPTIONS:

- ALTERNATE BOLT LENGTHS AND SPACINGS
- ALTERNATE AIR FITTING SIZES AND LOCATIONS
- NO BUMPER OR ALTERNATE BUMPER

RECOMMENDED MAX. TORQUE VALUES

3/4"-16 UNF COMBO STUD	1/4"-18 UNF AIR FITTING	1/2"-13 UNC STUD TYP. OF (3)
600 in-lb 50 ft-lb	240 in-lb 20 ft-lb	300 in-lb 25 ft-lb

NOTE: SEE GUIDELINES FOR PROPER APPLICATION OF THIS PRODUCT

LOAD vs. DEFLECTION @ CONSTANT PRESSURE

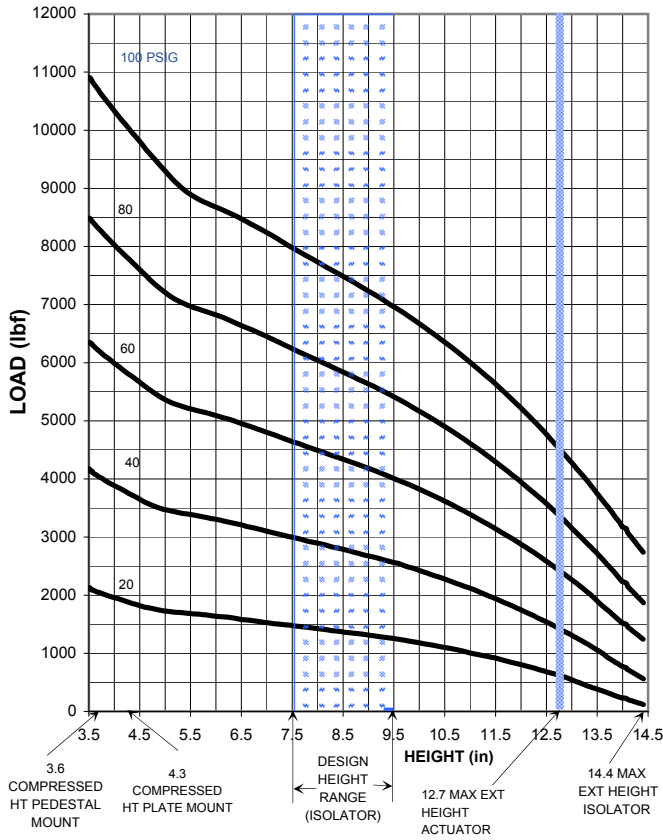

DYNAMIC DATA @ 8.5 in DESIGN HEIGHT

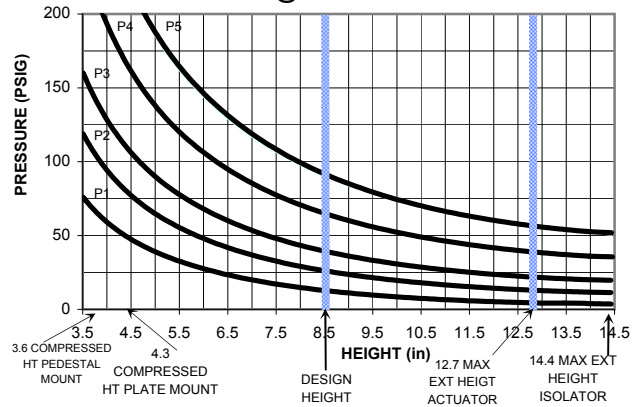

DYNAMIC DATA @ 8.5 in DESIGN HEIGHT

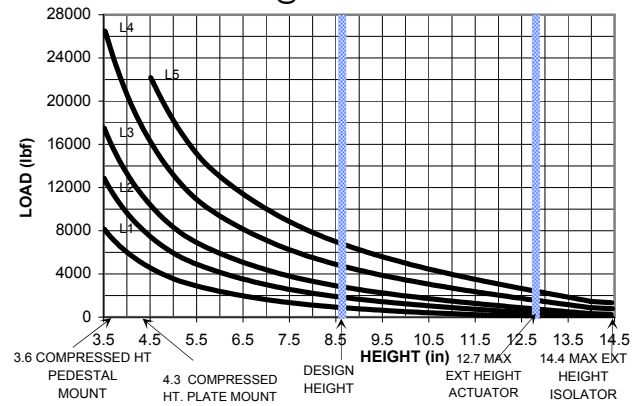

****NOTE: MAXIMUM INFLATION PRESSURE IS 100 PSIG. MAXIMUM JOUNCE PRESSURE IS 200 PSIG. IF YOUR APPLICATION WILL EXCEED THESE LIMITS, CONSULT A GOODYEAR ENGINEERED PRODUCTS REPRESENTATIVE FOR APPLICATION ASSISTANCE.**

CONSTANT PRESSURE CHARACTERISTICS

Assembly Height (in)	Volume @ 100 PSIG (in ³)	Nominal Force (lb)				
		@ 20 PSIG	@ 40 PSIG	@ 60 PSIG	@ 80 PSIG	@ 100 PSIG
		14.4	1169	70	460	1150
13.0	1094	580	1300	2200	3200	4300
12.7	1077	660	1400	2400	3400	4500
12.0	1032	850	1800	2900	4000	5200
11.0	961	1050	2200	3400	4700	6100
9.5	844	1300	2600	4100	5500	7100
8.5	761	1450	2900	4400	6000	7600
7.5	676	1500	3100	4700	6400	8100
6.0	545	1700	3400	5200	6900	8800
5.0	456	1800	3600	5500	7400	9400
4.3	393	1800	3800	5800	7800	10000
3.6	329	1980	4100	6300	8400	10000
3.5	320	2000	4200	6400	8600	11000

DYNAMIC CHARACTERISTICS

Design Height (in)	Load (lb)	Pressure (PSIG)	Spring Rate (lb/in)	Natural Frequency	
				cpm	Hz
9.5	1000	15	335	108	1.80
	2000	30	550	98	1.63
	3000	44	720	92	1.53
	5000	71	1115	89	1.48
8.5	1000	14	355	112	1.87
	2000	27	560	99	1.65
	3000	41	780	96	1.60
	5000	66	1180	91	1.52
7.5	1000	13	410	120	2.00
	2000	26	645	106	1.77
	3000	38	880	102	1.70
	5000	63	1310	96	1.60
7000	87	1755	94	1.57	

The GOODYEAR (and Winged Foot Design) trademark is used by Veyance Technologies, Inc. under license from The Goodyear Tire & Rubber Company. Goodyear Engineered Products are manufactured and sourced exclusively by Veyance Technologies, Inc. or its affiliates. The following trademarks are licensed to Veyance Technologies, Inc. by The Goodyear Tire & Rubber Company, including Compass, Eagle Pd, Flexten, Gatorback and GY Metric. ©2008 Veyance Technologies, Inc. All Rights Reserved.



2B14-354

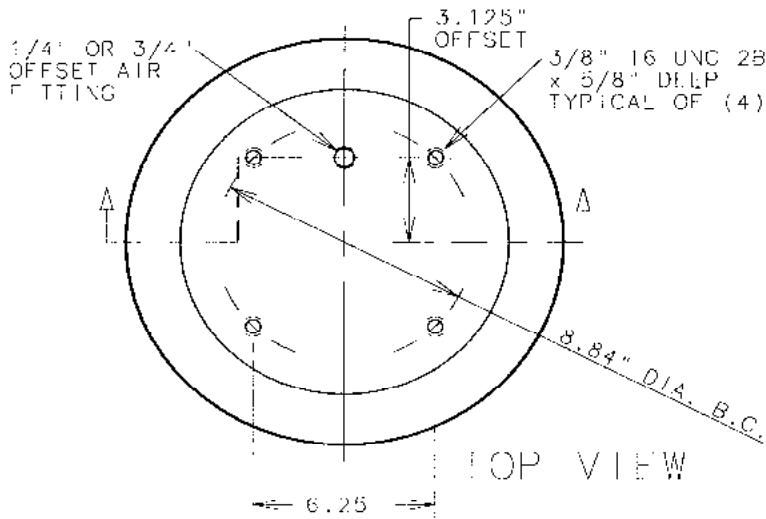

ASSEMBLY NUMBER	ELASTOMER	AIR FITTING	BUMPER INCLUDED
2B14-354	NAT. RUBBER	1/4"-18 NPTF OFFSET 3.125"	NO
2B14-355	NAT. RUBBER	1/4"-18 NPTF OFFSET 3.125"	YES
2B14-352	NAT. RUBBER	3/4"-14 NPTF OFFSET 3.125"	NO
2B14-353	NAT. RUBBER	3/4"-14 NPTF OFFSET 3.125"	YES
578923353 FLEXEMBER ONLY	NAT. RUBBER	----	--

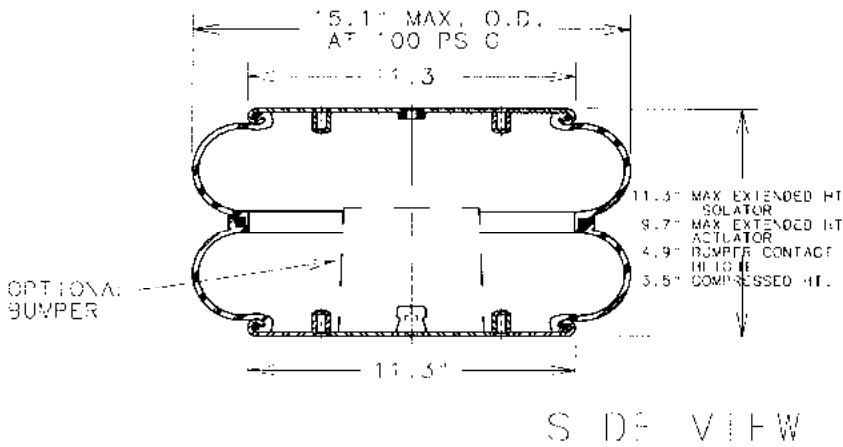

SPRING FEATURES:

- LOAD RANGE (ISOLATOR).....1500-11100 lb
- DESIGN HEIGHT RANGE (ISOLATOR).....7.5-9.5 in
- USEABLE STROKE w/o BUMPER (ACTUATOR)....6.0 in
- USEABLE STROKE WITH BUMPER (ACTUATOR)....4.8 in
- ASSEMBLY WEIGHT.....18.5 lb
- FORCE TO COMPRESS AT 0 PSIG (APPROX.)...165 lb
- NOMINAL FREE STANDING HT. AT 0 PSIG.....8.5 in

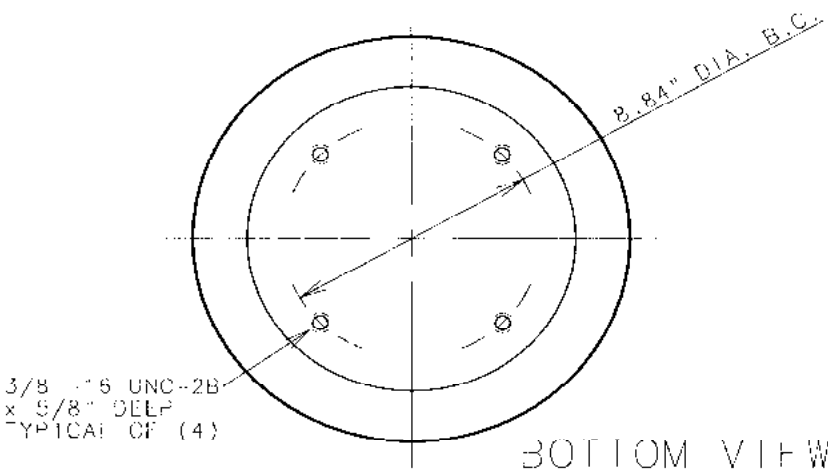

RECOMMENDED MAX. TORQUE VALUES

3/8"-16 UNC BLIND TAP TYP. OF (8)	1/4"-18 UNC AIR FITTING	3/4"-14 UNC AIR FITTING
500 in-lb 25 ft-lb	240 in-lb 20 ft-lb	240 in-lb 20 ft-lb

NOTE: SEE GUIDELINES FOR PROPER APPLICATION OF THIS PRODUCT

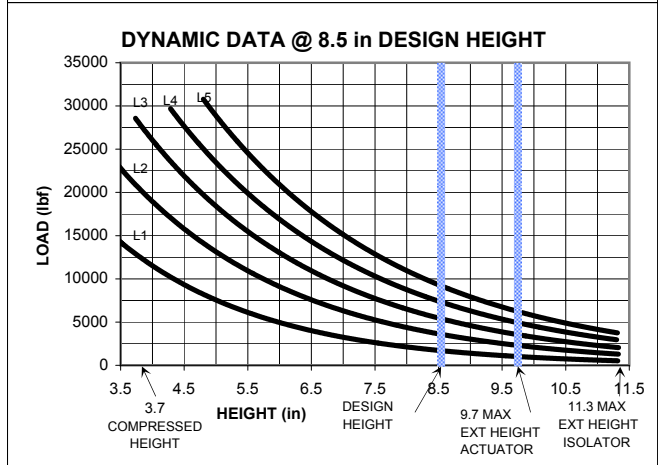
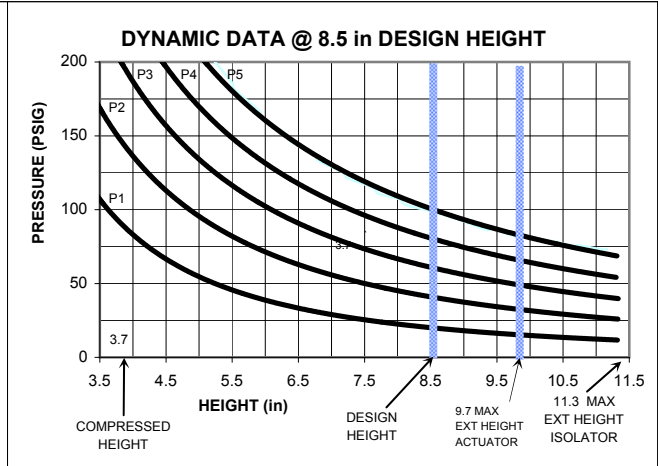
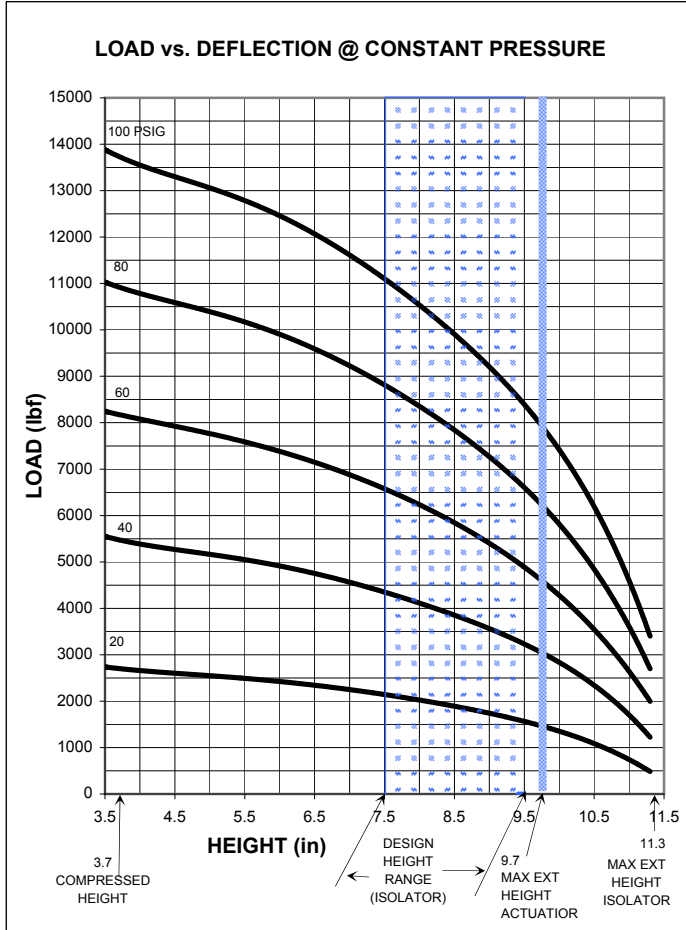

****NOTE: MAXIMUM INFLATION PRESSURE IS 100 PSIG. MAXIMUM JOUNCE PRESSURE IS 200 PSIG. IF YOUR APPLICATION WILL EXCEED THESE LIMITS, CONSULT A GOODYEAR ENGINEERED PRODUCTS AIR SPRINGS REPRESENTATIVE FOR APPLICATION ASSISTANCE.**

CONSTANT PRESSURE CHARACTERISTICS

Assembly Height (in)	Volume @ 100 PSIG (in ³)	Nominal Force (lb)				
		@ 20 PSIG	@ 40 PSIG	@ 60 PSIG	@ 80 PSIG	@ 100 PSIG
11.3	1244	480	1200	2000	2700	3400
10.5	1189	1100	2300	3500	5600	6200
9.7	1119	1400	3000	4600	6500	7900
9.5	1100	1500	3200	4900	6600	8400
9.0	1046	1700	3500	5400	7300	9200
8.5	994	1900	3900	5900	7900	10000
7.5	879	2200	4400	6600	8900	11100
6.5	756	2400	4800	7200	9700	12200
5.5	631	2500	5100	7600	10300	12900
4.5	509	2600	5300	8000	10700	13200
3.7	413	2650	5350	8100	10900	13700
3.5	389	2700	5400	8200	11000	13900

DYNAMIC CHARACTERISTICS

Design Height (in)	Load (lb)	Pressure (PSIG)	Spring Rate (lb/in)	Natural Frequency	
				cpm	Hz
9.5	2000	24	810	119	1.98
	4000	48	1435	112	1.87
	6000	70	2015	109	1.82
	8000	93	2615	107	1.78
8.5	2000	20	730	114	1.90
	4000	41	1305	107	1.78
	6000	61	1830	104	1.73
	8000	80	2355	102	1.70
7.5	10000	99	2860	100	1.67
	2000	18	805	119	1.98
	4000	36	1370	109	1.82
	6000	54	1860	105	1.75
7.5	8000	72	2395	103	1.72
	10000	90	2925	102	1.70

The GOODYEAR (and Winged Foot Design) trademark is used by Veyance Technologies, Inc. under license from The Goodyear Tire & Rubber Company. Goodyear Engineered Products are manufactured and sourced exclusively by Veyance Technologies, Inc. or its affiliates. The following trademarks are licensed to Veyance Technologies, Inc. by The Goodyear Tire & Rubber Company, including Compass, Eagle Pd, Flexten, Gatorback and GY Metric. ©2008 Veyance Technologies, Inc. All Rights Reserved.



2B14-362

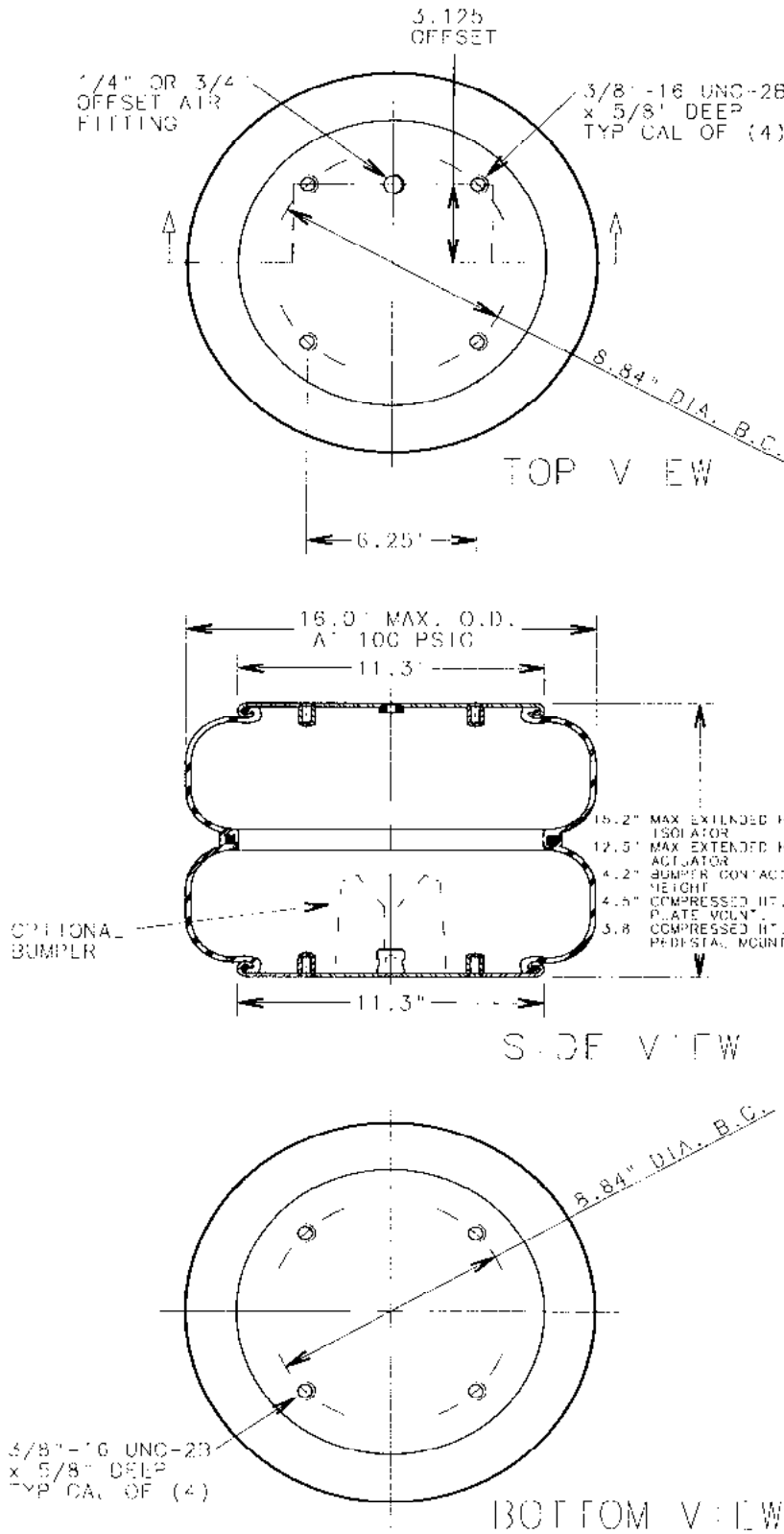

ASSEMBLY NUMBER	FLASICOMER	AIR FITTING	BUMPER INCLUDED
2B14-362	NAT. RUBBER	1/4"-18 NPTF OFFSET 3.125"	NO
2B14-363	NAT. RUBBER	3/4" 14 NPTF OFFSET 3.125"	NO
2B14-452	NAT. RUBBER	1/4"-18 NPTF OFFSET 3.125"	YES
5/8923356 EXXIMVBR ONLY	NAT. RUBBER	----	---

SPRING FEATURES:

- LOAD RANGE (ISOLATOR).....2000-3100 lb
- DESIGN HEIGHT RANGE (ISOLATOR).....7.5-9.5 in
- USEABLE STROKE w/o BUMPER (ACTUATOR)....8.0 in PLATE MOUNT
- USEABLE STROKE WITH BUMPER (ACTUATOR)....11.0 in
- USEABLE STROKE w/o BUMPER (ACTUATOR)....8.7 in PEDISTAL MOUNT
- ASSEMBLY WEIGHT.....19.2 lb
- FORCE TO COMPRESS AT 0 PSIG (APPROX.)....70 lb
- NOMINAL FREE STANDING HT. AT 0 PSIG....9.7 in

RECOMMENDED MAX. TORQUE VALUES

3/8"-16 UNC BOND TAP TYP. OF (8)	1/4" 18 UNC AIR FITTING	3/4"-14 UNC AIR FITTING
390 in-lb 25 ft-lb	240 in-lb 20 ft-lb	240 in-lb 20 ft-lb

NOTE: SEE CATALOGS FOR PROPER APPLICATION OF THIS PRODUCT

LOAD vs. DEFLECTION @ CONSTANT PRESSURE

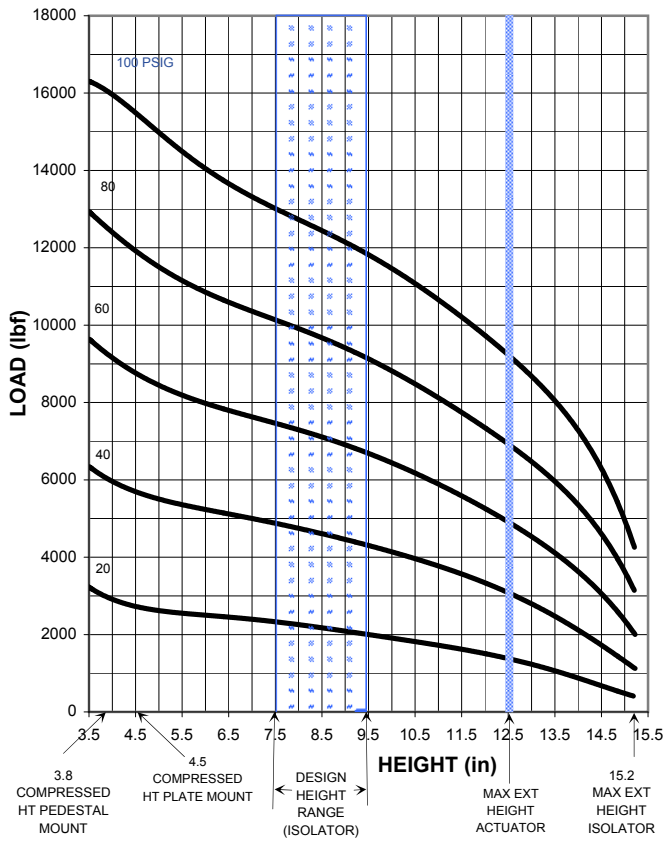

DYNAMIC DATA @ 8.5 in DESIGN HEIGHT

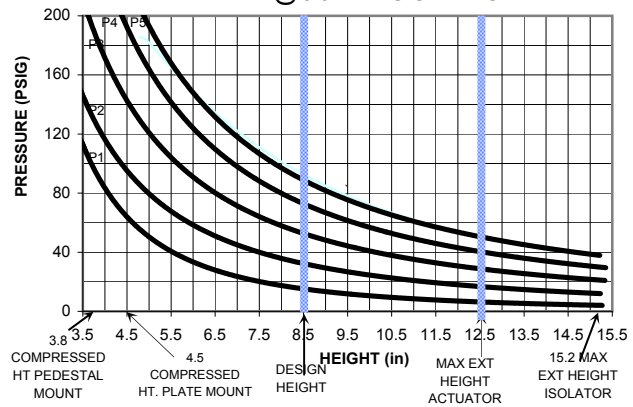

DYNAMIC DATA @ 8.5 in DESIGN HEIGHT

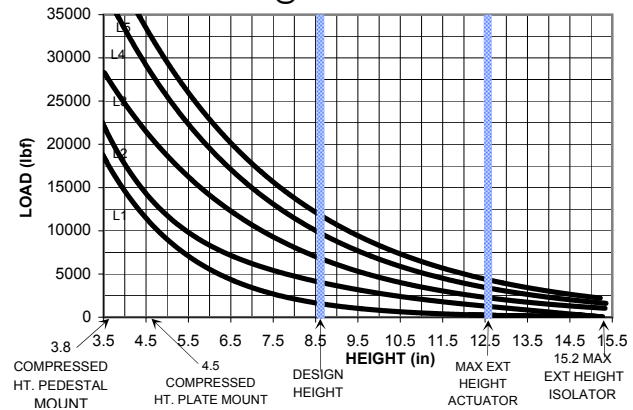

****NOTE: MAXIMUM INFLATION PRESSURE IS 100 PSIG. MAXIMUM JOUNCE PRESSURE IS 200 PSIG. IF YOUR APPLICATION WILL EXCEED THESE LIMITS, CONSULT A GOODYEAR ENGINEERED PRODUCTS AIR SPRINGS REPRESENTATIVE FOR APPLICATION ASSISTANCE.**

CONSTANT PRESSURE CHARACTERISTICS

Assembly Height (in)	Volume @ 100 PSIG (in ³)	Nominal Force (lb)				
		@ 20 PSIG	@ 40 PSIG	@ 60 PSIG	@ 80 PSIG	@ 100 PSIG
		15.2	1900	320	1100	2000
14.0	1806	800	2000	3500	5200	7100
12.5	1655	1350	3000	4800	6800	9100
11.0	1477	1700	3800	5900	8100	10600
9.5	1283	2000	4300	6700	9100	11800
8.5	1149	2200	4600	7100	9700	12500
7.5	1012	2300	4900	7500	10200	13100
6.0	806	2500	5200	7900	10700	13800
4.5	605	2700	5700	8800	12000	15700
3.8	511	3000	6000	9300	12500	16000
3.5	469	3200	6300	9600	12900	16200

DYNAMIC CHARACTERISTICS

Design Height (in)	Load (lb)	Pressure (PSIG)	Spring Rate (lb/in)	Natural Frequency	
				cpm	Hz
9.5	2000	18	620	104	1.73
	4000	35	990	93	1.55
	7000	61	1565	89	1.48
	10000	87	2100	86	1.43
8.5	2000	17	650	107	1.78
	4000	33	1055	97	1.62
	7000	58	1640	91	1.52
	10000	82	2235	89	1.48
7.5	12000	97	2625	88	1.47
	2000	16	750	115	1.92
	4000	31	1170	102	1.70
	7000	54	1810	96	1.60
7.5	10000	78	2450	93	1.55
	12000	94	2895	92	1.53

The GOODYEAR (and Winged Foot Design) trademark is used by Veyance Technologies, Inc. under license from The Goodyear Tire & Rubber Company. Goodyear Engineered Products are manufactured and sourced exclusively by Veyance Technologies, Inc. or its affiliates. The following trademarks are licensed to Veyance Technologies, Inc. by The Goodyear Tire & Rubber Company, including Compass, Eagle Pd, Flexten, Gatorback and GY Metric. ©2008 Veyance Technologies, Inc. All Rights Reserved.



2B15-375

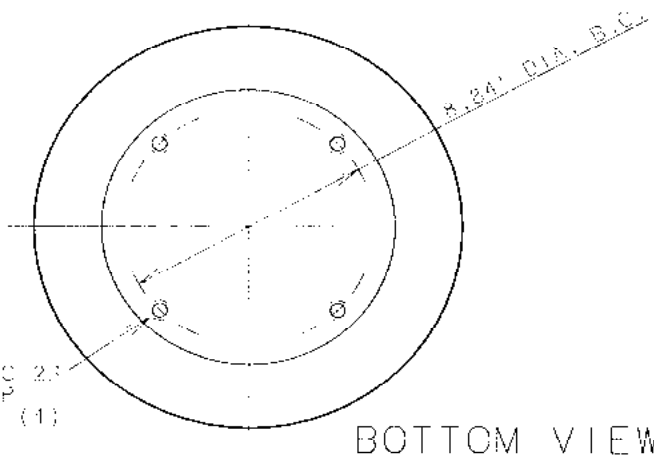
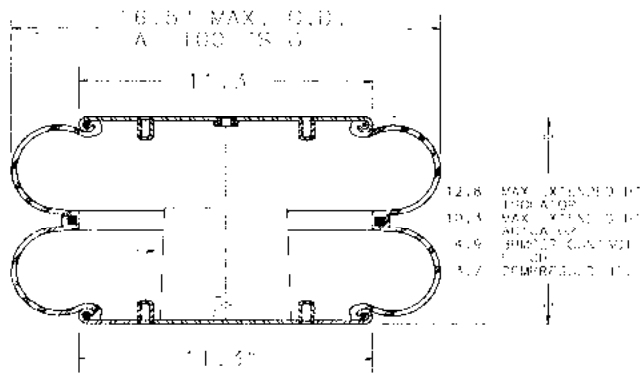
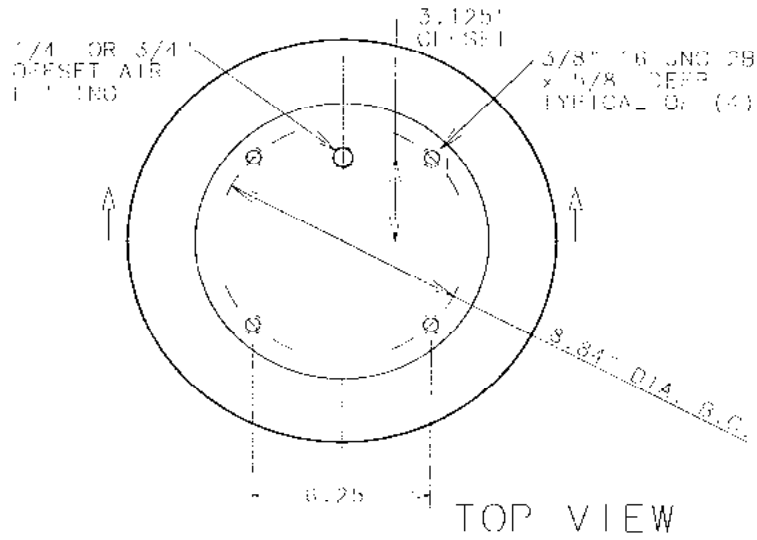

ASSEMBLY NUMBER	ELASTOMER	AIR LINE	BUMPERS EXCLUDED
2B15-375	NAT. RUBBER	1/4"-18 NPTL OFFSET 3.125"	NO
2B15-376	NAT. RUBBER	1/4"-18 NPTL 1"-18" 3.125"	YES
2B15-377	NAT. RUBBER	3/4"-14 NPTL OFFSET 3.125"	NO
2B15-378	NAT. RUBBER	3/4"-14 NPTL OFFSET 3.125"	YES
K1603377 SILICONE ONLY	NAT. RUBBER		

SPRING FEATURES:

- LOAD RANGE (ISOLATOR).....2000-12300 lbs
- LOAD ON BUSHING RANGE (SOLE-02).....2.0-9.5 lbs
- STABLE STROKE w/o BUMPER (ACTUAL).....6.6 in
- STABLE STROKE WITH BUMPER (ACTUAL).....6.4 in
- ASSEMBLY WEIGHT.....19.9 lb
- FORCE TO COMPRESS AT 0% S.D. (MAX.).....180 lb
- NOMINAL TRUCK R AND NO. HILL AT 0% S.D.4.2 in

RECOMMENDED MAX. TORQUE VALUES

3/8" 16 UNC PERM. TAP W/ 1/8" (1)	1/4" 18 UNC AIR LINE	3/4" 14 UNC AIR LINE
500 in-lb 25 ft-lb	240 in-lb 20 ft-lb	240 in-lb 20 ft-lb

NOTE: SEE GUIDELINES FOR PROPER APPLICATION OF THIS PRODUCT

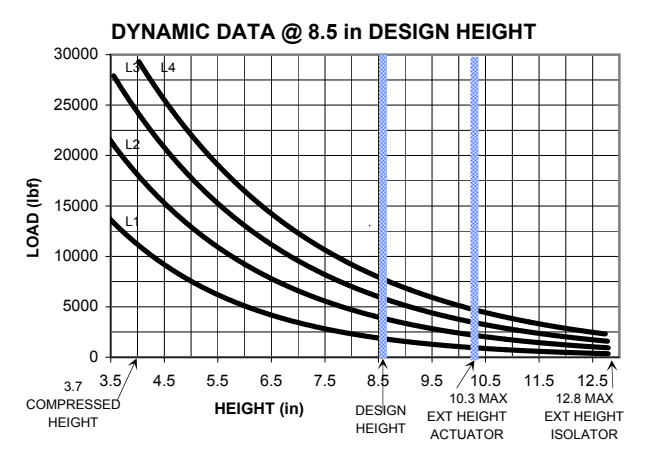
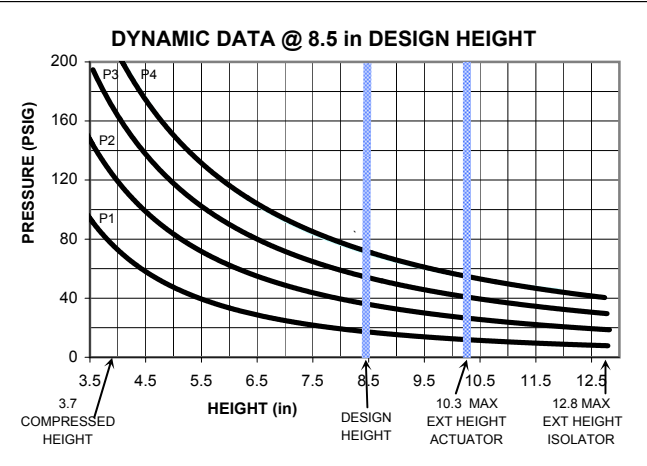
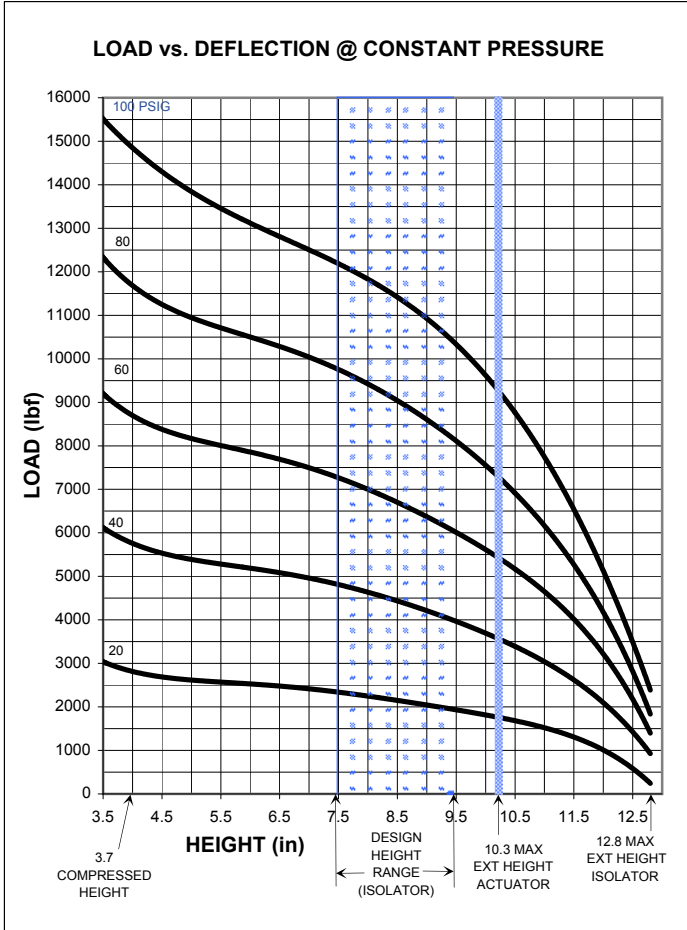

****NOTE: MAXIMUM INFLATION PRESSURE IS 100 PSIG. MAXIMUM JOUNCE PRESSURE IS 200 PSIG. IF YOUR APPLICATION WILL EXCEED THESE LIMITS, CONSULT A GOODYEAR ENGINEERED PRODUCTS AIR SPRINGS REPRESENTATIVE FOR APPLICATION ASSISTANCE.**

CONSTANT PRESSURE CHARACTERISTICS

Assembly Height (in)	Volume @ 100 PSIG (in ³)	Nominal Force (lb)				
		@ 20 PSIG	@ 40 PSIG	@ 60 PSIG	@ 80 PSIG	@ 100 PSIG
		12.8	1615	300	1000	1500
11.5	1472	1300	2600	4000	5200	6500
10.5	1373	1700	3400	5200	7000	8800
10.3	1348	1800	3500	5400	7200	9000
9.5	1259	2000	4000	6100	8200	10300
8.5	1135	2300	4500	6800	9100	11400
7.5	1008	2500	4900	7300	9900	12300
6.5	875	2600	5100	7800	10500	13200
5.5	740	2700	5300	8200	11100	13700
4.5	605	2800	5500	8500	11400	14200
3.7	500	2900	5800	9000	12100	15100
3.5	475	3000	6000	9200	12400	15500

DYNAMIC CHARACTERISTICS

Design Height (in)	Load (lb)	Pressure (PSIG)	Spring Rate (lb/in)	Natural Frequency	
				cpm	Hz
9.5	2000	20	660	108	1.80
	4000	39	1140	100	1.67
	6000	58	1610	97	1.62
	8000	78	2085	95	1.58
8.5	2000	18	680	109	1.82
	4000	35	1150	100	1.67
	6000	53	1605	97	1.62
	8000	70	2050	95	1.58
7.5	2000	16	765	116	1.93
	4000	33	1230	104	1.73
	6000	49	1690	100	1.67
	8000	65	2155	97	1.62
	12000	97	3090	95	1.58

The GOODYEAR (and Winged Foot Design) trademark is used by Veyance Technologies, Inc. under license from The Goodyear Tire & Rubber Company. Goodyear Engineered Products are manufactured and sourced exclusively by Veyance Technologies, Inc. or its affiliates. The following trademarks are licensed to Veyance Technologies, Inc. by The Goodyear Tire & Rubber Company, including Compass, Eagle Pd, Flexten, Gatorback and GY Metric. ©2008 Veyance Technologies, Inc. All Rights Reserved.



2B19-8433

24 BOLTS EQUALLY SPACED
3/8" -24UNF BY 2.05" O.A.L.

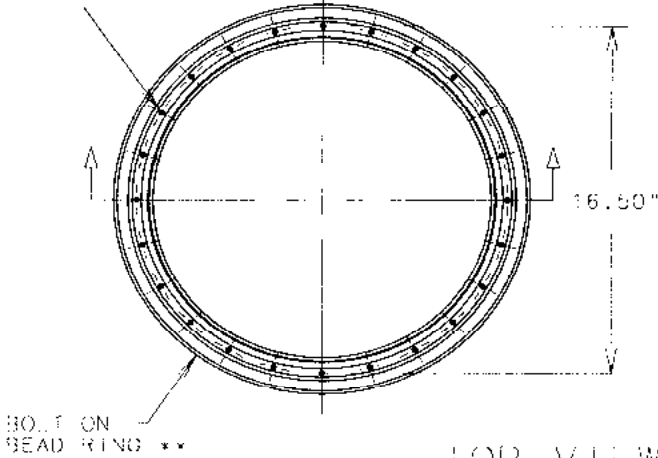

TOP VIEW

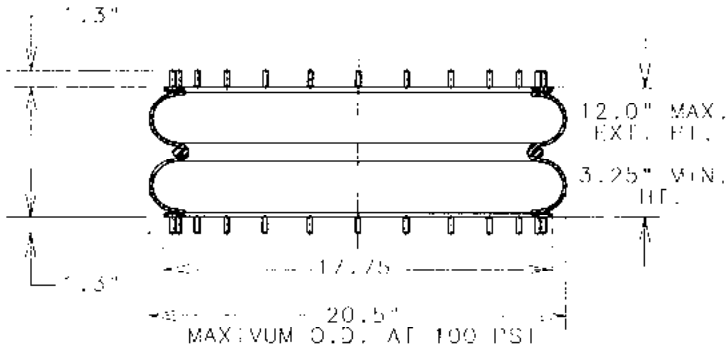

SIDE VIEW

24 BOLTS EQUALLY SPACED
3/8" -24UNF BY 2.05" O.A.L.

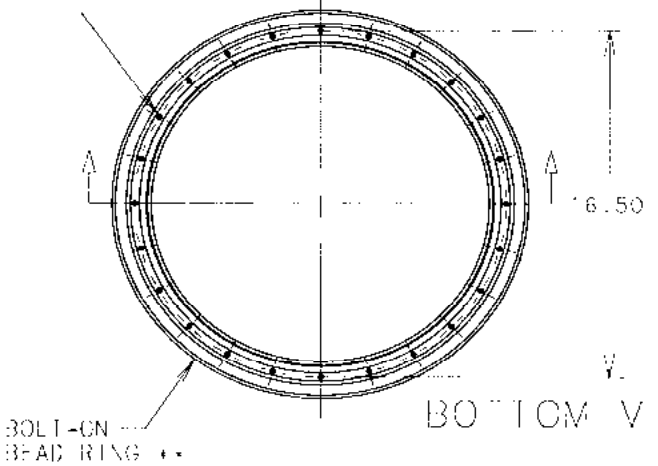

BOTTOM VIEW

ASSEMBLY NUMBER	HEAD RINGS	BOLTS/NUTS /WASHERS
2B19-8423	2 PCS	48 PCS M10x1.5
2B19-8433	2 PCS	48 PCS = 3/8" -24UNF

FLEX MEMBER - 556-23-8203

SPRING FEATURES:

- LOAD RANGE3200-23700 lb
- DESIGN HEIGHT RANGE (ISOLATOR).....7.0-10.0 in
- USEABLE STROKE8.75 in
- ASSEMBLY WEIGHT (NO PLATES).....20.0 lb
- BEAD RING (BOLT-ON).....ALUMINUM

** CUSTOMER TO PROVIDE END PLATES TO MATCH BOLT PATTERN. END PLATE WOULD HAVE AIRLEAKING

RECOMMENDED MAX. TORQUE VALUES

3/8"-24UNF	M10 x 1.5
300 in-lb 25 ft-lb	34 N-m

NOTE: SEE GOODYEAR BELT FOR PROPER APPLICATION OF THIS PRODUCT

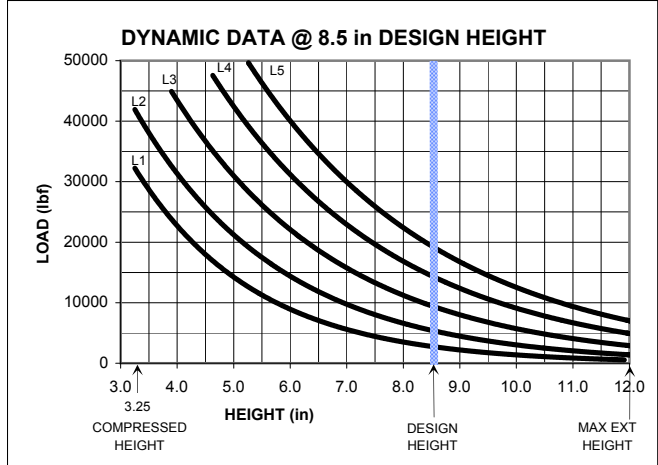
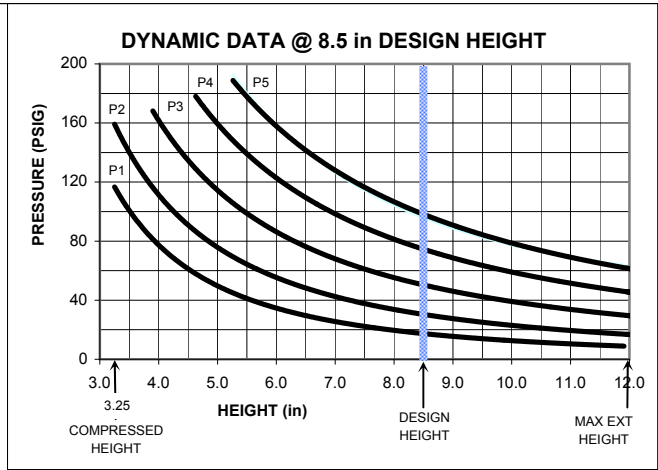
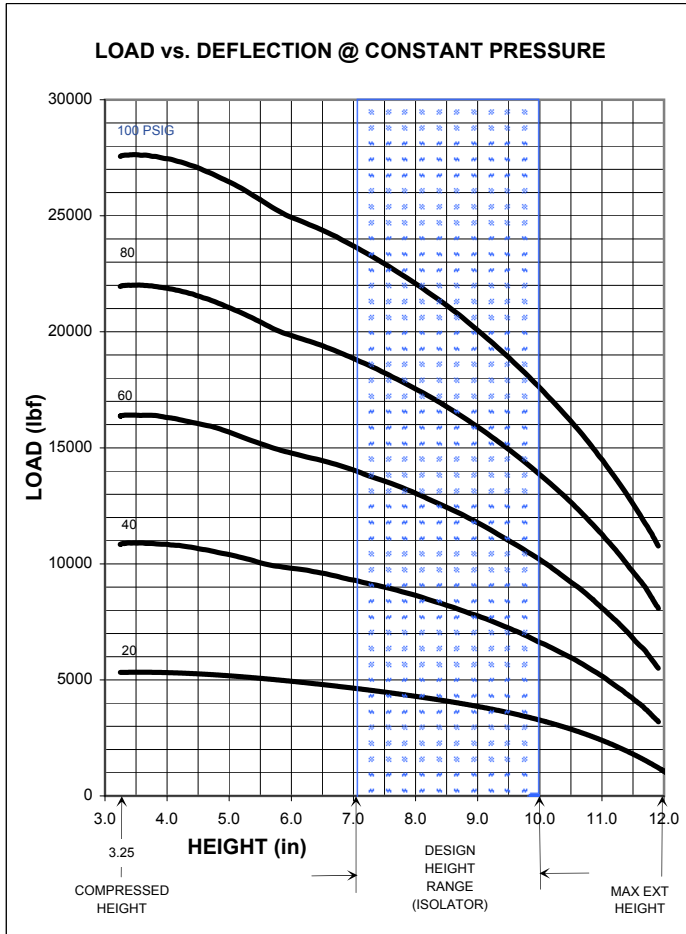

****NOTE: MAXIMUM INFLATION PRESSURE IS 100 PSIG. MAXIMUM JOUNCE PRESSURE IS 200 PSIG. IF YOUR APPLICATION WILL EXCEED THESE LIMITS, CONSULT A GOODYEAR ENGINEERED PRODUCTS AIR SPRINGS REPRESENTATIVE FOR APPLICATION ASSISTANCE.**

CONSTANT PRESSURE CHARACTERISTICS

Assembly Height (in)	Volume @ 100 PSIG (in ³)	Nominal Force (lb)				
		@ 20 PSIG	@ 40 PSIG	@ 60 PSIG	@ 80 PSIG	@ 100 PSIG
		12.0	2802	1150	3100	5400
11.0	2662	2400	5200	8000	11400	14700
10.0	2483	3200	6600	10000	13800	17700
8.5	2453	4100	8200	12500	16800	21200
7.0	2188	4600	9300	14100	18800	23700
6.0	2036	4900	9800	14800	19800	24900
5.0	1681	5100	10400	15700	21000	26500
4.0	1293	5300	10800	16300	21800	27400
3.25	876	5400	10900	16400	21900	27500

DYNAMIC CHARACTERISTICS

Design Height (in)	Load (lb)	Pressure (PSIG)	Spring Rate (lb/in)	Natural Frequency	
				cpm	Hz
10.0	3500	22	1285	114	1.90
	6000	36	1990	108	1.80
	10000	58	2975	103	1.72
	15000	85	4155	99	1.65
8.5	3500	18	1250	112	1.87
	6000	30	1860	105	1.75
	10000	49	2790	99	1.65
	15000	72	3905	96	1.60
7.0	20000	96	5030	94	1.57
	3500	16	1480	122	2.03
	6000	27	2095	111	1.85
	10000	44	3105	105	1.75
15000	66	4290	101	1.68	
	20000	87	5495	99	1.65

The GOODYEAR (and Winged Foot Design) trademark is used by Veyance Technologies, Inc. under license from The Goodyear Tire & Rubber Company. Goodyear Engineered Products are manufactured and sourced exclusively by Veyance Technologies, Inc. or its affiliates. The following trademarks are licensed to Veyance Technologies, Inc. by The Goodyear Tire & Rubber Company, including Compass, Eagle Pd, Flexten, Gatorback and GY Metric. ©2008 Veyance Technologies, Inc. All Rights Reserved.



2B22-8539

24 BOLTS EQUALLY SPACED
3/8" -24UNF BY 2.05" O.A.L.

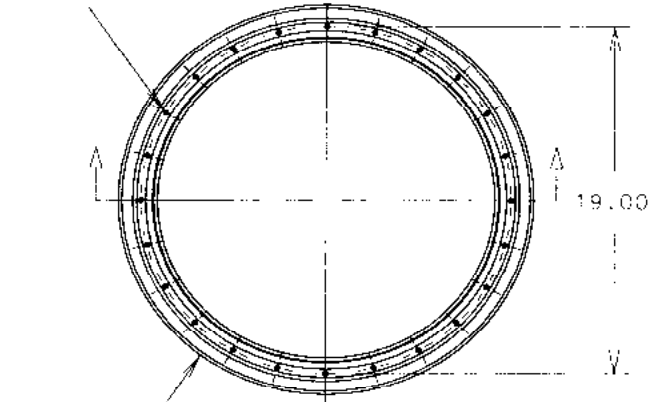

TOP VIEW

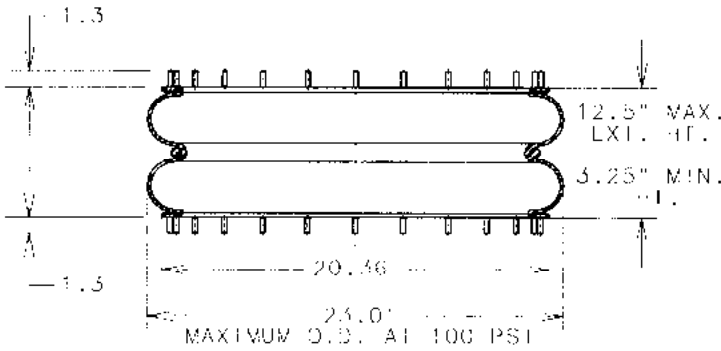

SIDE VIEW

24 BOLTS EQUALLY SPACED
3/8" -24UNF BY 2.05" O.A.L.

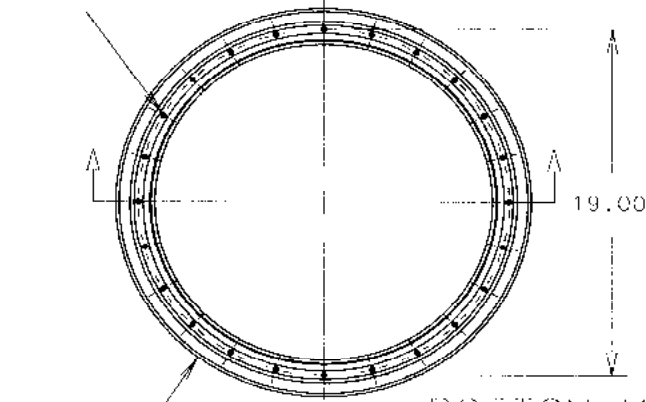

BOTTOM VIEW

BOLT-ON
BEAD RING **

ASSEMBLY NUMBER	BEAD RINGS	BOLTS/NUTS /WASHERS
2B22-8529	2 PCS	48 PCS = M10x1.5
2B22-8539	2 PCS	48 PCS = 3/8 -24UNF
FLEX MEMBER = 556-23-8350		

SPRING FEATURES:

- LOAD RANGE 5200-31700 lb
- DESIGN HEIGHT RANGE 7.0-9.0 in
- UNSTABLE STROKE 9.25 in
- ASSEMBLY WEIGHT (NO PLATES)..... 24.3 lb
- BEAD RING (BOLT-ON)..... ALUMINUM

** CUSTOMER TO PROVIDE END PLATES TO MATCH BOLT PATTERN. END PLATE WOULD HAVE AIRFITTING

OTHER OPTIONS:

- SNAP ON VERSION
- EXTENDED P.L.V. VERSION

RECOMMENDED MAX. TORQUE VALUES

3/8"-24UNF	M10 x 1.5
300 in-lb 25 ft-lb	34 Nm

NOTE: SEE GUIDELINES FOR PROPER APPLICATION OF THIS PRODUCT

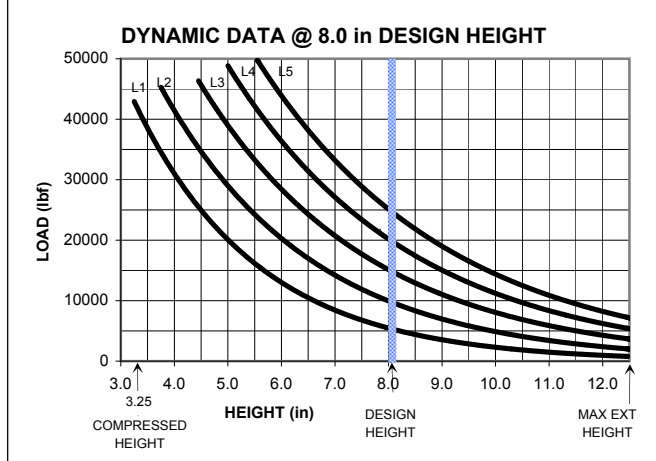
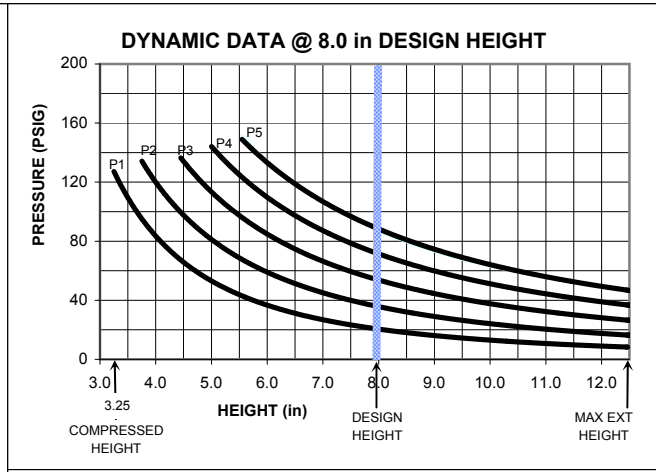
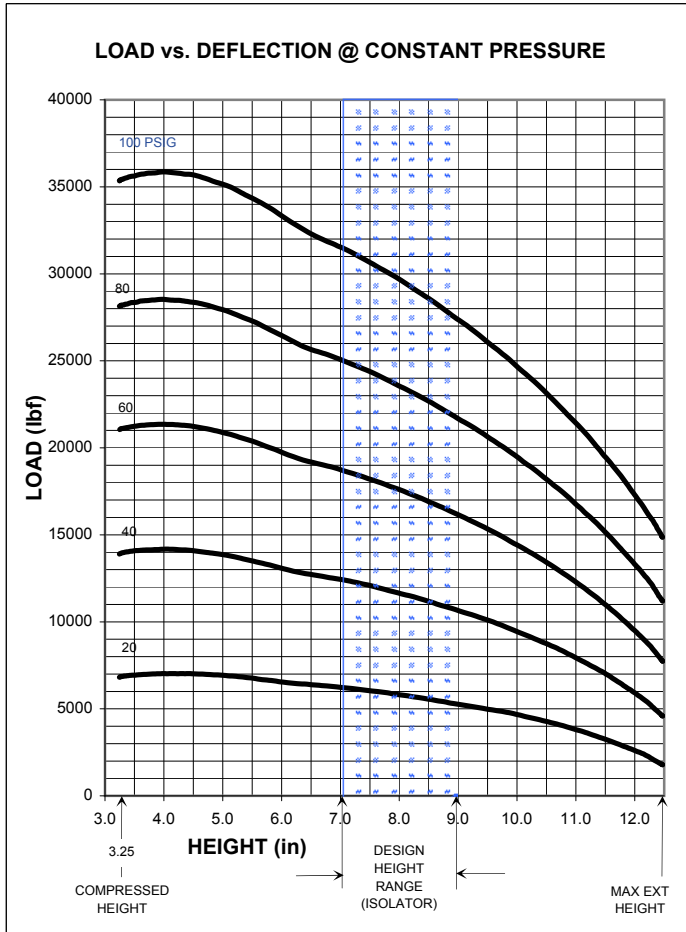

****NOTE: MAXIMUM INFLATION PRESSURE IS 100 PSIG. MAXIMUM JOUNCE PRESSURE IS 200 PSIG. IF YOUR APPLICATION WILL EXCEED THESE LIMITS, CONSULT A GOODYEAR ENGINEERED PRODUCTS AIR SPRINGS REPRESENTATIVE FOR APPLICATION ASSISTANCE.**

CONSTANT PRESSURE CHARACTERISTICS

Assembly Height (in)	Volume @ 100 PSIG (in ³)	Nominal Force (lb)				
		@ 20 PSIG	@ 40 PSIG	@ 60 PSIG	@ 80 PSIG	@ 100 PSIG
		12.5	3317	1700	4500	7700
11.5	3095	3300	7000	11000	15400	19800
10.5	2877	4300	8800	13500	18500	23500
9.0	2509	5200	10700	16200	21900	27700
8.0	2470	5700	11600	17600	23700	29800
7.0	1919	6200	12400	18800	25200	31700
6.0	1601	6500	13100	19800	26600	33600
5.0	1215	6900	13800	20800	28000	35200
4.0	840	7000	14100	21300	28500	35800
3.25	716	6800	13800	21000	28100	35300

DYNAMIC CHARACTERISTICS

Design Height (in)	Load (lb)	Pressure (PSIG)	Spring Rate (lb/in)	Natural Frequency	
				cpm	Hz
9.0	6000	23	1880	105	1.75
	10000	38	2740	98	1.63
	15000	56	3790	95	1.58
	20000	74	4815	92	1.53
	25000	92	5795	90	1.50
8.0	6000	21	2025	109	1.82
	10000	36	2885	101	1.68
	15000	53	4025	97	1.62
	20000	70	5065	95	1.58
	25000	87	6210	94	1.57
7.0	6000	21	2235	115	1.92
	10000	34	3230	107	1.78
	15000	51	4395	102	1.70
	20000	67	5590	99	1.65
	25000	83	6780	98	1.63

The GOODYEAR (and Winged Foot Design) trademark is used by Veyance Technologies, Inc. under license from The Goodyear Tire & Rubber Company. Goodyear Engineered Products are manufactured and sourced exclusively by Veyance Technologies, Inc. or its affiliates. The following trademarks are licensed to Veyance Technologies, Inc. by The Goodyear Tire & Rubber Company, including Compass, Eagle Pd, Flexten, Gatorback and GY Metric. ©2008 Veyance Technologies, Inc. All Rights Reserved.



3B12-304

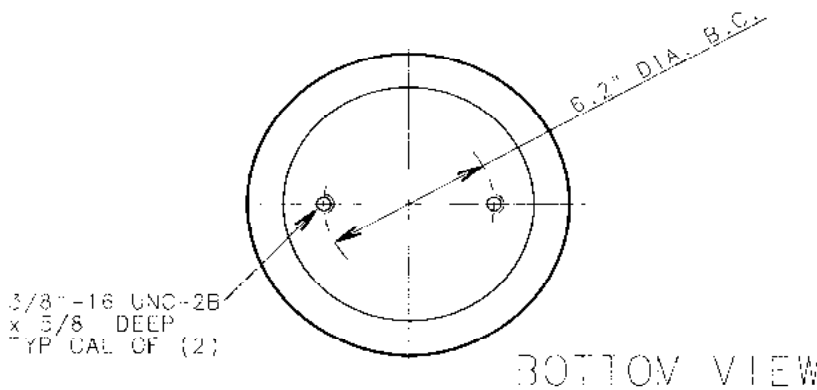
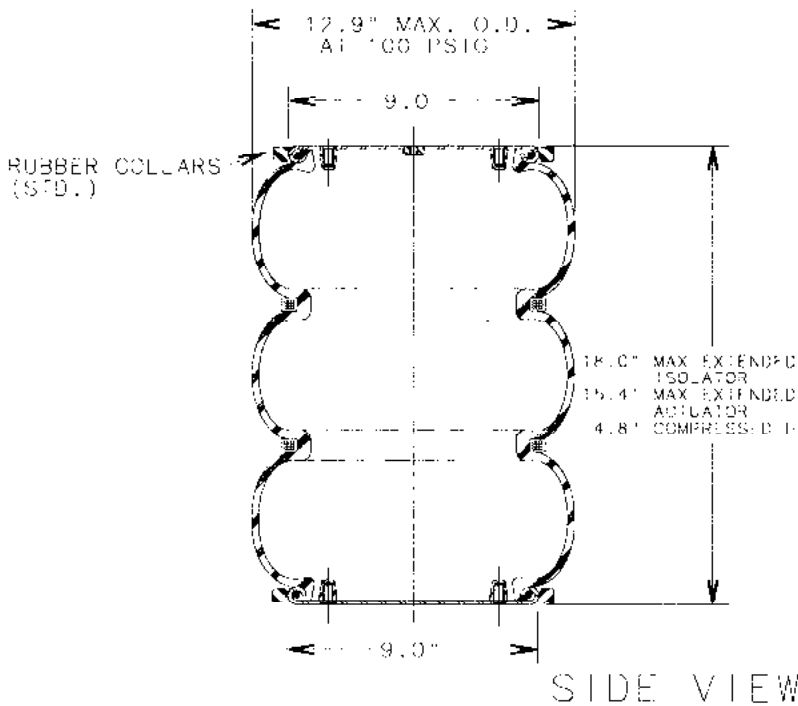
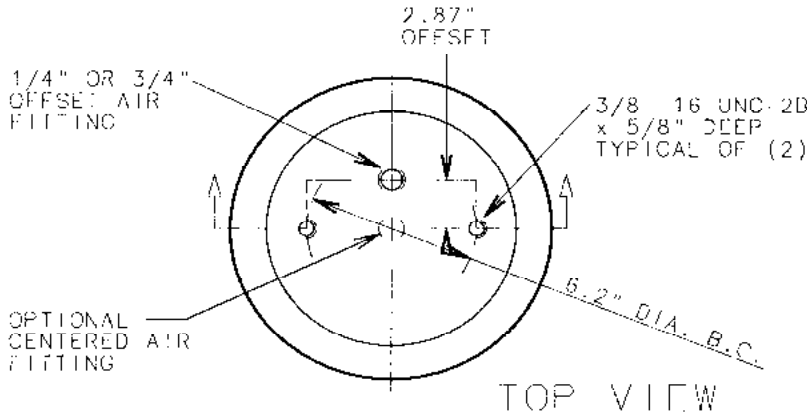

ASSEMBLY NUMBER	ELASTOMER	AIR FITTING	BUMPER INCLUDED
3B12-304	NAT. RUBBER	1/4"-18 NPT OFFSET 2.87"	NO
3B12-305	NAT. RUBBER	3/4"-14 NPT OFFSET 2.87"	NO
3B12-308	NAT. RUBBER	1/4"-18 NPT CENTERED	NO
578933100 FLEXMATH ONLY	NAT. RUBBER	---	---

SPRING FEATURES:

- LOAD RANGE (ISOLATOR).....850-7000 lb
- DESIGN HEIGHT RANGE (ISOLATOR).....13.0-15.0 in
- USEABLE STROKE (ACTUATOR).....10.0 in
- ASSEMBLY WEIGHT.....15.3 lb
- FORCE TO COMPRESS AT 0 PSIG (APPROX.).....70 lb
- NOMINAL FREE STANDING HT. AT 0 PSIG.....7.6 in

RECOMMENDED MAX. TORQUE VALUES

3/8"-16 UNC BLIND TAP TYP. OF (4)	1/4"-18 UNC AIR FITTING	3/4"-14 UNC AIR FITTING
300 in.-lb 25 ft.-lb	240 in.-lb 20 ft.-lb	240 in.-lb 20 ft.-lb

NOTE: SEE CATALOGS FOR PROPER APPLICATION OF THIS PRODUCT

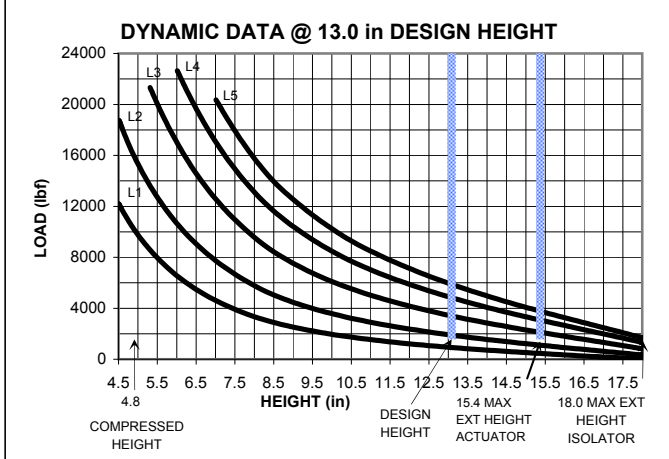
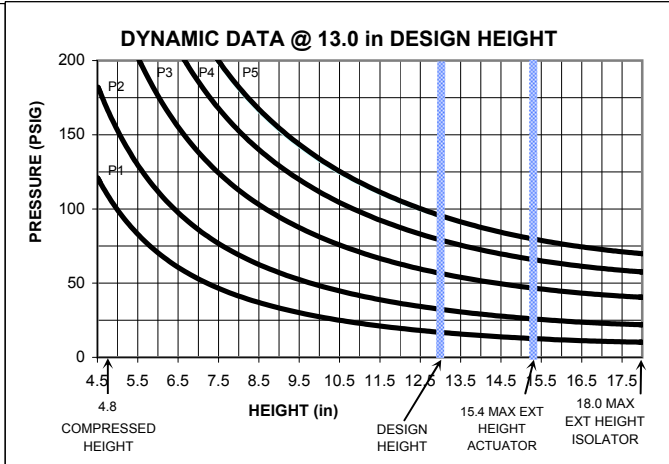
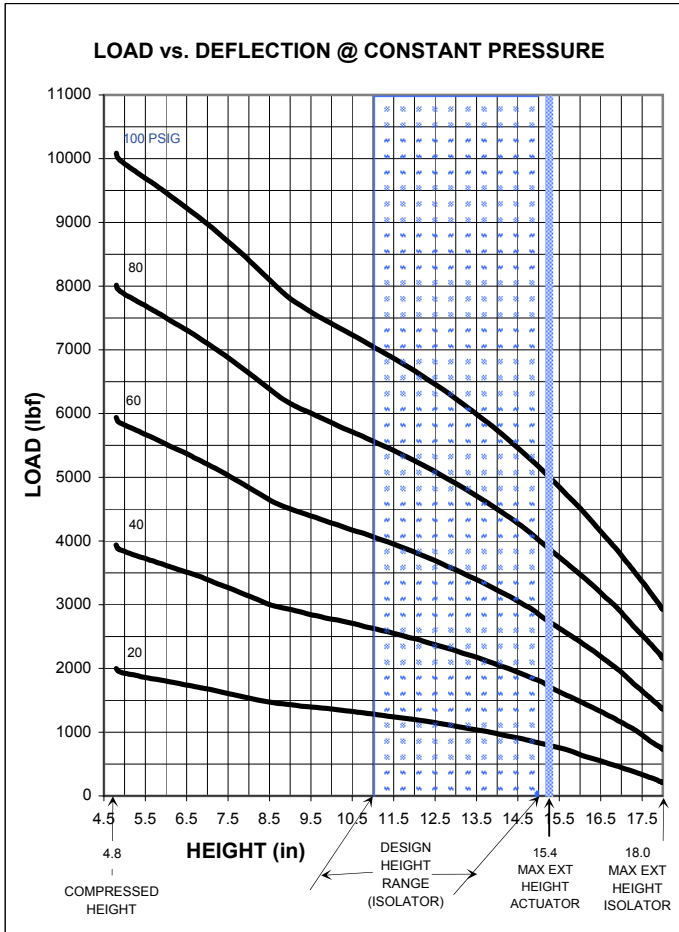

****NOTE: MAXIMUM INFLATION PRESSURE IS 100 PSIG. MAXIMUM JOUNCE PRESSURE IS 200 PSIG. IF YOUR APPLICATION WILL EXCEED THESE LIMITS, CONSULT A GOODYEAR ENGINEERED PRODUCTS AIR SPRINGS REPRESENTATIVE FOR APPLICATION ASSISTANCE.**

CONSTANT PRESSURE CHARACTERISTICS

Assembly Height (in)	Volume @ 100 PSIG (in ³)	Nominal Force (lb)				
		@ 20 PSIG	@ 40 PSIG	@ 60 PSIG	@ 80 PSIG	@ 100 PSIG
18.0	1302	200	700	1350	2100	2900
17.0	1261	460	1150	1900	2900	3800
16.0	1214	700	1500	2400	3500	4600
15.4	1183	790	1700	2700	3800	4600
15.0	1159	850	1800	2900	4000	5200
13.0	1033	1150	2300	3600	5000	6400
11.0	890	1350	2700	4100	5600	7100
9.0	732	1500	2900	4500	6200	8100
7.0	568	1700	3500	5300	7300	9200
6.0	486	1800	3700	5600	7600	9600
4.8	390	1980	3900	5800	7900	10000
4.7	383	2000	3900	5800	7900	10000

DYNAMIC CHARACTERISTICS

Design Height (in)	Load (lb)	Pressure (PSIG)	Spring Rate (lb/in)	Natural Frequency	
				cpm	Hz
15.0	1000	22	275	99	1.65
	2000	41	455	91	1.52
	3500	69	735	87	1.45
	5000	98	1010	84	1.40
13.0	1000	18	280	100	1.67
	2000	33	435	88	1.47
	3500	58	655	81	1.35
	5000	80	900	80	1.33
11.0	6000	96	1070	79	1.32
	1000	15	275	98	1.63
	2000	29	450	89	1.48
	3500	51	680	83	1.38
11.0	5000	71	950	82	1.37
	6000	85	1110	80	1.33

The GOODYEAR (and Winged Foot Design) trademark is used by Veyance Technologies, Inc. under license from The Goodyear Tire & Rubber Company. Goodyear Engineered Products are manufactured and sourced exclusively by Veyance Technologies, Inc. or its affiliates. The following trademarks are licensed to Veyance Technologies, Inc. by The Goodyear Tire & Rubber Company, including Compass, Eagle Pd, Flexten, Gatorback and GY Metric. ©2008 Veyance Technologies, Inc. All Rights Reserved.



3B12-325

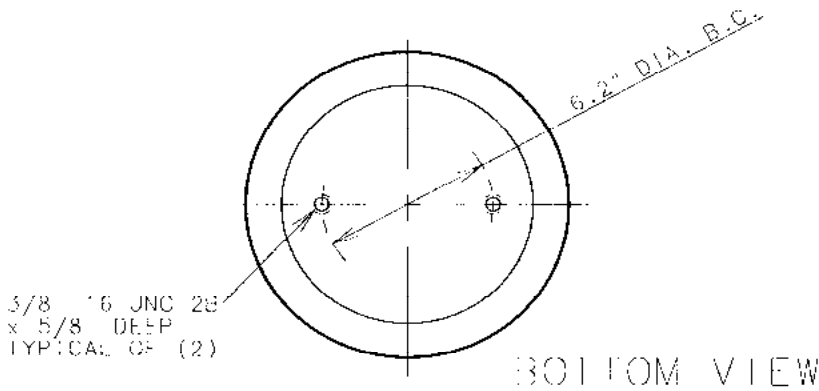
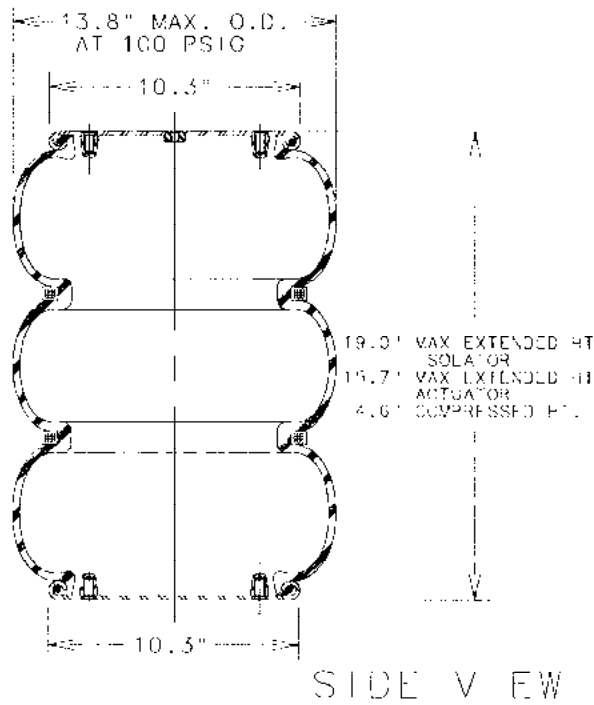
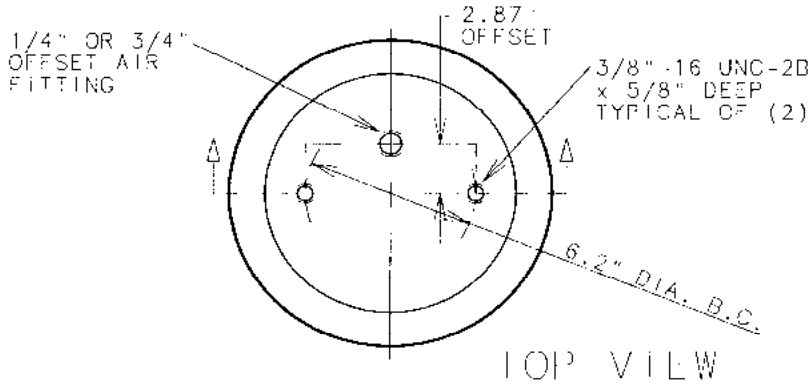

ASSEMBLY NUMBER	ELASTOMER	AIR FITTING	BUMPER INCLUDED
3B12-325	NAT. RUBBER	1/4"-18 NPTF OFFSET 2.87"	NO
3B12-326	NAT. RUBBER	3/4"-14 NPTF OFFSET 2.87"	NO
578933103 FLEXMEMBER ONLY	NAT. RUBBER	----	---

SPRING FEATURES:

- LOAD RANGE (ISOLATOR).....1100-8400 lb
- DESIGN HEIGHT RANGE (ISOLATOR)....11.0-15.0 in
- USEABLE STROKE (ACTUATOR).....11.1 in
- ASSEMBLY WEIGHT.....16.5 lb
- FORCE TO COMPRESS AT 0 PSIG (APPROX.)...100 lb
- NOMINAL FREE STAND-NO HT. AT 0 PSIG....10.5 in

RECOMMENDED MAX. TORQUE VALUES

3/8" .16 UNC BLIND TAP TYP. OF (4)	1/4"-18 UNC AIR FITTING	3/4"-14 UNC AIR FITTING
300 in-lb 25 ft-lb	240 in-lb 20 ft-lb	240 in-lb 20 ft-lb

NOTE: SEE GOODYEAR'S GUIDELINES FOR PROPER APPLICATION OF THIS PRODUCT

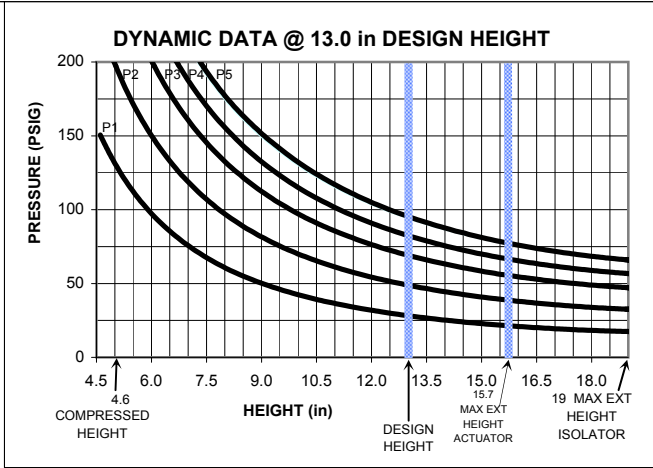
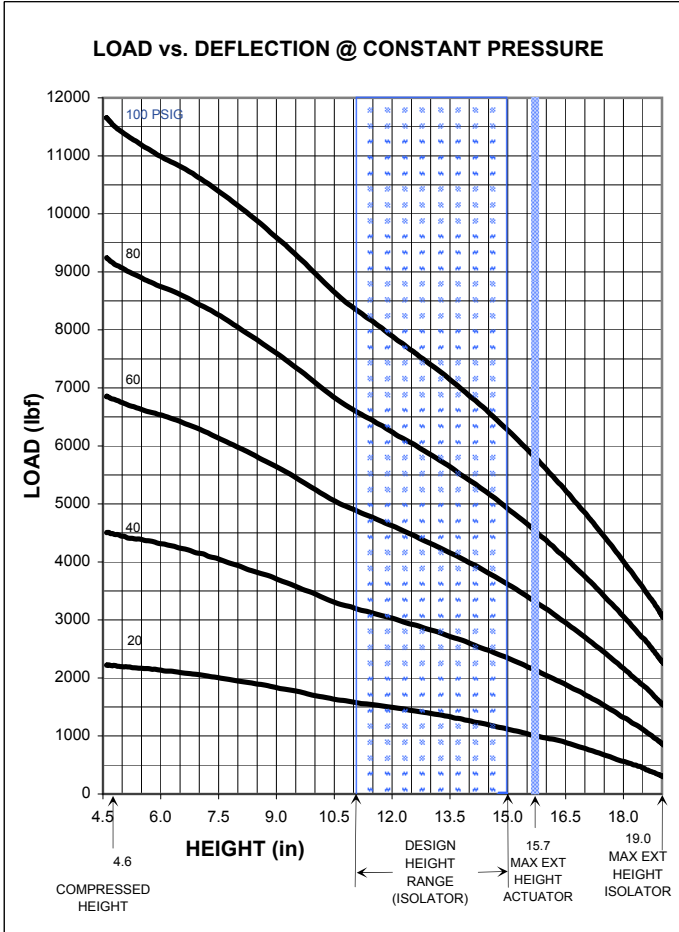

****NOTE: MAXIMUM INFLATION PRESSURE IS 100 PSIG. MAXIMUM JOUNCE PRESSURE IS 200 PSIG. IF YOUR APPLICATION WILL EXCEED THESE LIMITS, CONSULT A GOODYEAR ENGINEERED PRODUCTS AIR SPRINGS REPRESENTATIVE FOR APPLICATION ASSISTANCE.**

CONSTANT PRESSURE CHARACTERISTICS

Assembly Height (in)	Volume @ 100 PSIG (in ³)	Nominal Force (lb)				
		@ 20 PSIG	@ 40 PSIG	@ 60 PSIG	@ 80 PSIG	@ 100 PSIG
19.0	1598	300	800	1500	2200	2900
18.0	1550	550	1300	2100	3000	4000
17.0	1504	800	1700	2700	3700	4800
16.0	1440	950	2000	3200	4400	5600
15.7	1420	1000	2100	3300	4500	5800
15.0	1373	1100	2300	3600	4900	6300
13.0	1235	1400	2800	4300	5800	7400
11.0	1085	1550	3200	4900	6600	8400
9.0	892	1850	3700	5600	7600	9600
7.0	681	2050	4100	6300	8400	10600
6.0	560	2100	4250	6500	8700	10900
4.6	433	2100	4400	6700	9100	11500
4.5	429	2200	4500	6800	9200	11600

DYNAMIC CHARACTERISTICS

Design Height (in)	Load (lb)	Pressure (PSIG)	Spring Rate (lb/in)	Natural Frequency	
				cpm	Hz
15.0	2000	34	360	79	1.32
	3500	57	635	80	1.33
	5000	80	865	78	1.30
	6000	95	1020	77	1.28
13.0	2000	29	340	78	1.30
	3500	50	675	83	1.38
	5000	70	895	80	1.33
	6000	83	970	76	1.27
	7000	96	1135	75	1.25
11.0	2000	26	445	88	1.47
	3500	45	670	82	1.37
	5000	62	925	81	1.35
	6000	75	1080	80	1.33
	7000	86	1235	79	1.32

The GOODYEAR (and Winged Foot Design) trademark is used by Veyance Technologies, Inc. under license from The Goodyear Tire & Rubber Company. Goodyear Engineered Products are manufactured and sourced exclusively by Veyance Technologies, Inc. or its affiliates. The following trademarks are licensed to Veyance Technologies, Inc. by The Goodyear Tire & Rubber Company, including Compass, Eagle Pd, Flexten, Gatorback and GY Metric. ©2008 Veyance Technologies, Inc. All Rights Reserved.



3B14-354

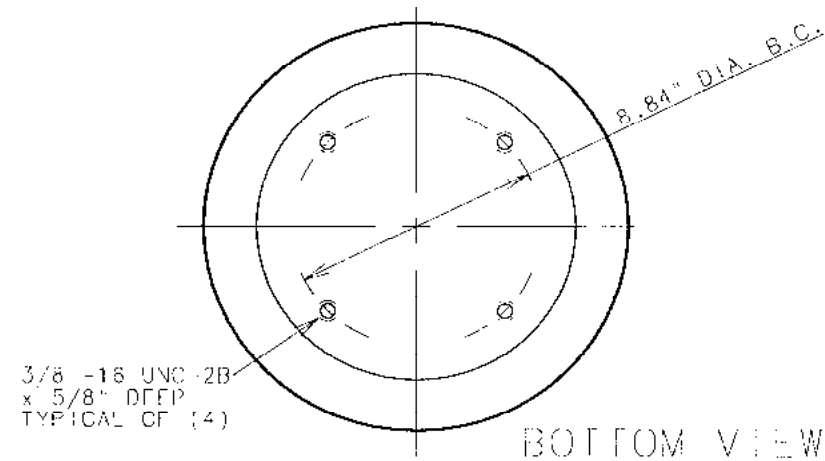
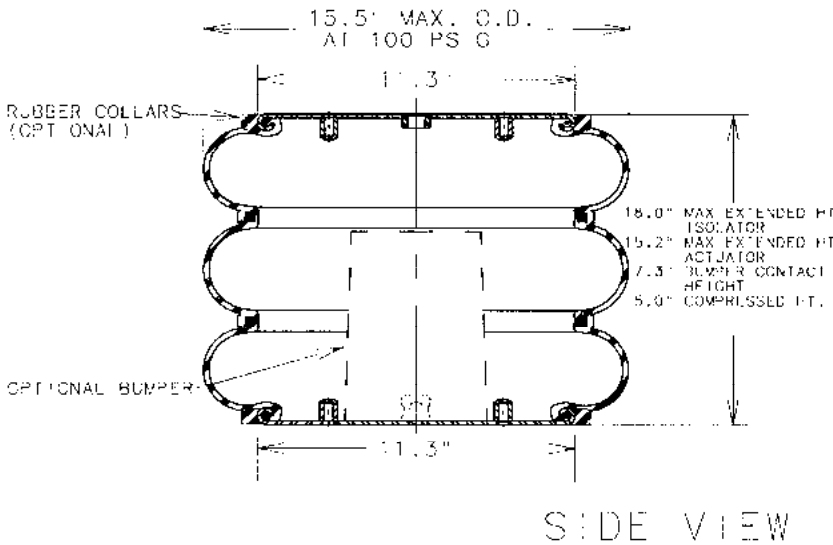
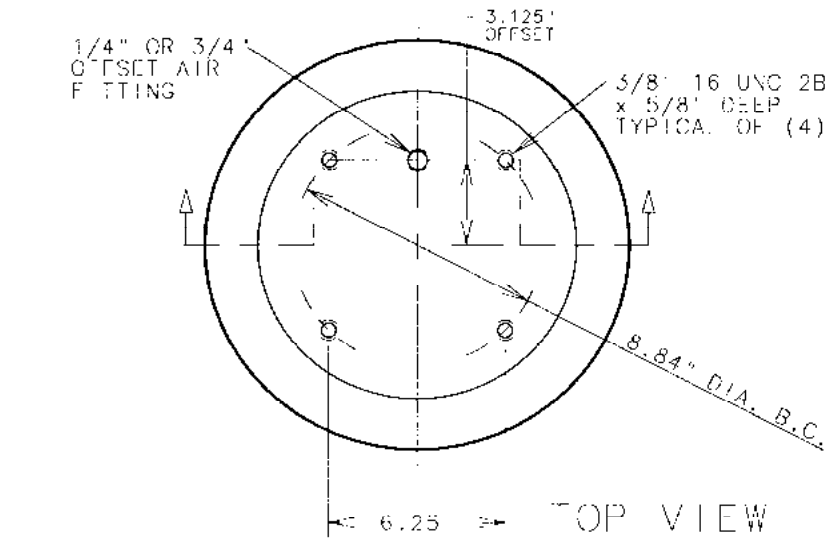

ASSEMBLY NUMBER	ELASTOMER	AIR FITTING	BUMPER INCLUDED	RUBBER COLLARS
3B14-354	NAT. RUBBER	1/4"-18 NPT OFFSET 3.125	NO	NO
3B14-351	NAT. RUBBER	1/4"-18 NPT OFFSET 3.125	YES	YES
3B14-361	NAT. RUBBER	3/4"-14 NPT OFFSET 3.125	NO	YES
3B14-353	NAT. RUBBER	3/4"-14 NPT OFFSET 3.125	YES	YES
3B14-403	NAT. RUBBER	1/4"-18 NPT OFFSET 3.125	NO	YES
578933350 FLEXMEMBER ONLY	NAT. RUBBER	---	---	---

SPRING FEATURES:

- LOAD RANGE (ISOLATOR).....1900-12100 lb
- DESIGN HEIGHT RANGE (ISOLATOR)....10.5-12.5 in
- USABLE STROKE w/o BUMPER (ACTUATOR)....10.2 in
- USABLE STROKE WITH BUMPER (ACTUATOR)....7.9 in
- ASSEMBLY WEIGHT.....21.2 lb
- TORQUE TO COMPRESS AT 0 PSIG (APPROX.)....72 lb
- NOMINAL FREE STANDING HT. AT 0 PSIG....9.8 in

RECOMMENDED MAX. TORQUE VALUES

3/8" -16 UNC ELASTOMER TYP. OF (4)	1/4"-18 UNC AIR FITTING	3/4"-14 UNC AIR FITTING
300 in-lb 25 ft-lb	240 in-lb 20 ft-lb	240 in-lb 20 ft-lb

NOTE: SEE DIMENSION LINES FOR PROPER APPLICATION OF THIS PRODUCT

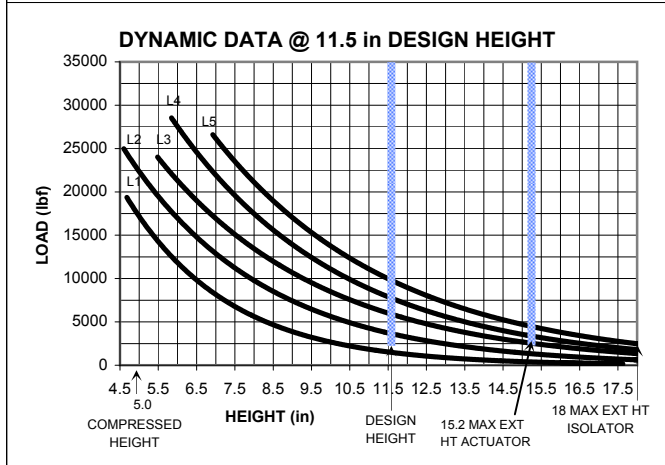
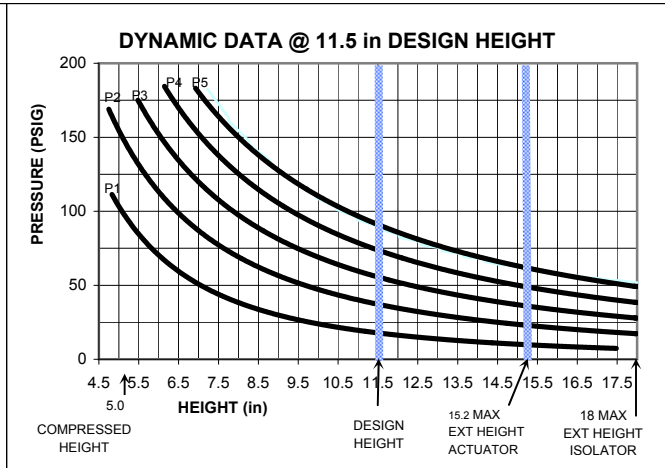
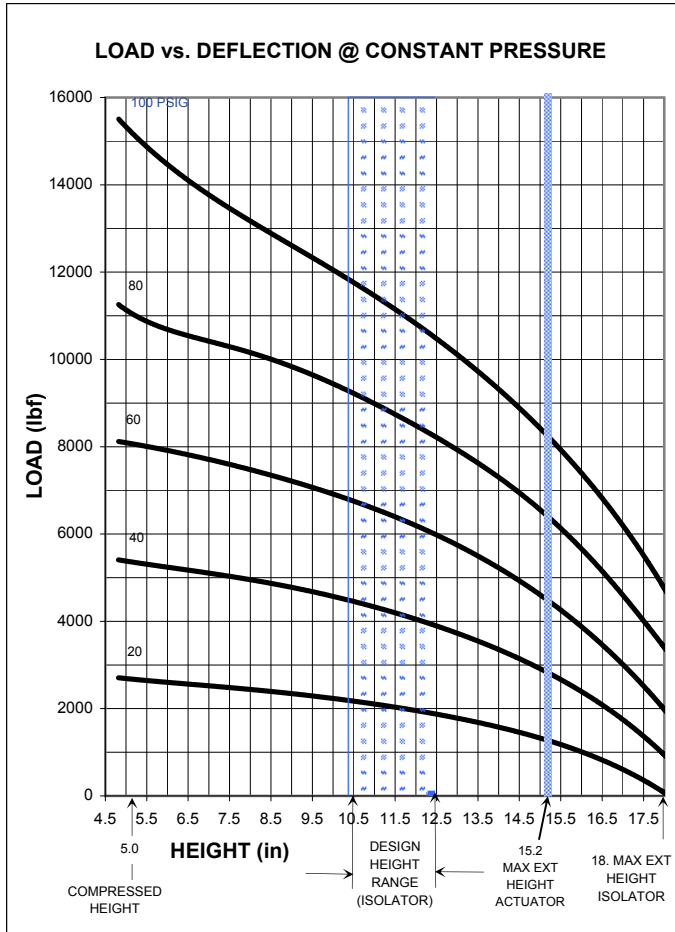

****NOTE: MAXIMUM INFLATION PRESSURE IS 100 PSIG. MAXIMUM JOUNCE PRESSURE IS 200 PSIG. IF YOUR APPLICATION WILL EXCEED THESE LIMITS, CONSULT A GOODYEAR ENGINEERED PRODUCTS AIR SPRINGS REPRESENTATIVE FOR APPLICATION ASSISTANCE.**

CONSTANT PRESSURE CHARACTERISTICS

Assembly Height (in)	Volume @ 100 PSIG (in ³)	Nominal Force (lb)				
		@ 20 PSIG	@ 40 PSIG	@ 60 PSIG	@ 80 PSIG	@ 100 PSIG
		18.0	2052	80	900	1900
16.0	1885	1050	2400	3900	5700	7500
15.2	1807	1200	2800	4500	6300	8300
14.0	1680	1600	3400	5300	7400	9500
12.5	1508	1900	4000	6100	8000	10700
11.5	1387	2100	4300	6500	9000	11400
10.5	1262	2200	4600	6900	9500	12100
9.0	1067	2400	4900	7400	10100	13000
7.0	805	2600	5200	7800	10600	14000
6.0	673	2600	5300	8000	10800	14700
5.0	541	2600	5300	8100	11000	1500
4.7	502	2700	5400	8200	11000	15200

DYNAMIC CHARACTERISTICS

Design Height (in)	Load (lb)	Pressure (PSIG)	Spring Rate (lb/in)	Natural Frequency	
				cpm	Hz
12.5	2000	20	510	95	1.58
	4000	39	840	86	1.43
	6000	58	1150	82	1.37
	8000	77	1460	80	1.33
	10000	95	1770	79	1.32
11.5	2000	19	530	97	1.62
	4000	37	870	88	1.47
	6000	55	1195	74	1.23
	8000	72	1540	82	1.37
	10000	90	1885	81	1.35
10.5	2000	18	570	101	1.68
	4000	35	940	91	1.52
	6000	52	1300	88	1.47
	8000	69	1655	86	1.43
	10000	85	2050	85	1.42

The GOODYEAR (and Winged Foot Design) trademark is used by Veyance Technologies, Inc. under license from The Goodyear Tire & Rubber Company. Goodyear Engineered Products are manufactured and sourced exclusively by Veyance Technologies, Inc. or its affiliates. The following trademarks are licensed to Veyance Technologies, Inc. by The Goodyear Tire & Rubber Company, including Compass, Eagle Pd, Flexten, Gatorback and GY Metric. ©2008 Veyance Technologies, Inc. All Rights Reserved.



3B14-450

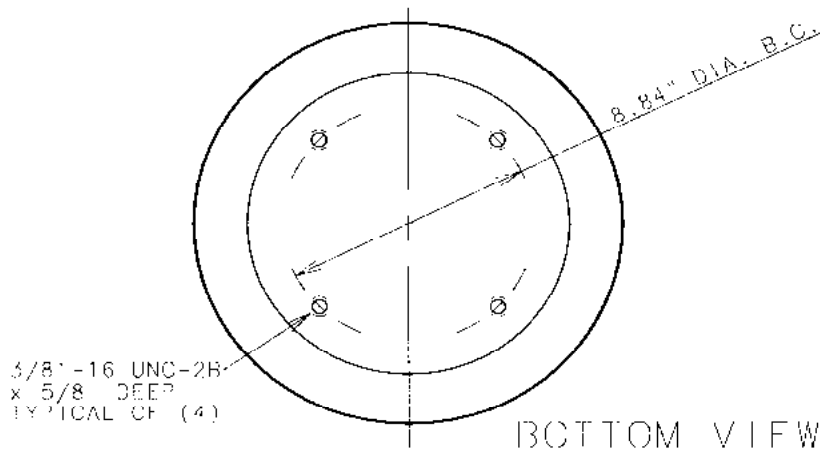
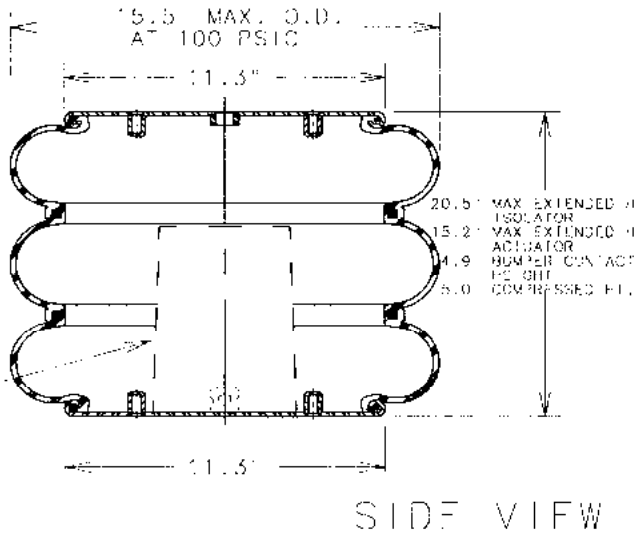
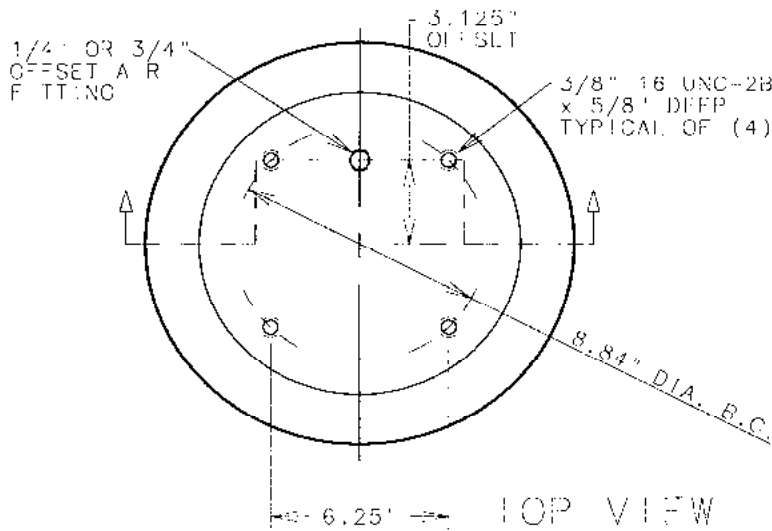

ASSEMBLY NUMBER	ELASTOMER	AIR FITTING	BUMPER INCLUDED
3B14-450	NAT. RUBBER	1/4"-18 NPT OFFSET 3.125"	NO
3B14-453	NAT. RUBBER	1/4"-18 NPT OFFSET 3.125"	YES
3B14-374	NAT. RUBBER	3/4"-14 NPT OFFSET 3.125"	NO
3B14-411	NAT. RUBBER	3/4"-14 NPT OFFSET 3.125"	YES
MEMBER ONLY	NAT. RUBBER		--

SPRING FEATURES:

- LOAD RANGE (ISOLATOR).....1700-11000 lb
- DESIGN HEIGHT RANGE (ISOLATOR)....10.5-12.5 in
- USABLE STROKE w/o BUMPER (ACTUATOR)....10.2 in
- USABLE STROKE WITH BUMPER (ACTUATOR)....10.3 in
- ASSEMBLY HEIGHT.....22.0 in
- FORCE TO COMPRESS AT 0 PSIG INTERNAL PRESSURE NO BUMPER: 120 LBS TO GO TO 4.25" HEIGHT

OTHER OPTIONS:

- UPPER BEAD PLATE:
- 3/4" OFFSET AIR FITTING
- LOWER BEAD PLATE:
- BUMPER

RECOMMENDED MAX. FORCE VALUES

3/8" - 16 UNC BLIND TAP TYP. OF (6)	1/4"-18 UNC AIR FITTING	3/4"-14 UNC AIR FITTING
300 in-lb 25 ft-lb	240 in-lb 20 ft-lb	240 in-lb 20 ft-lb

NOTE: SEE GUIDELINES FOR PROPER APPLICATION OF THIS PRODUCT

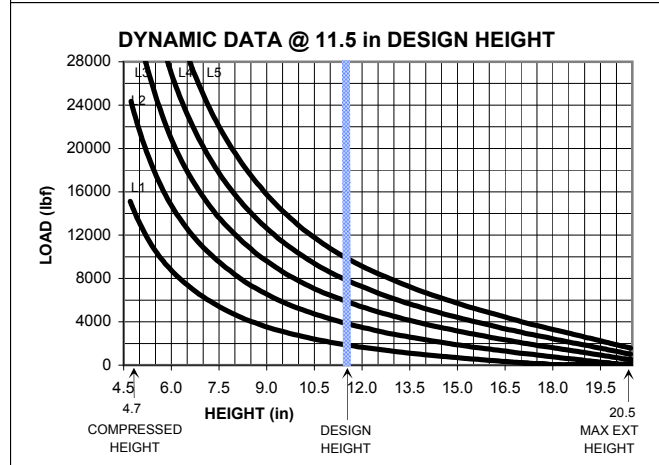
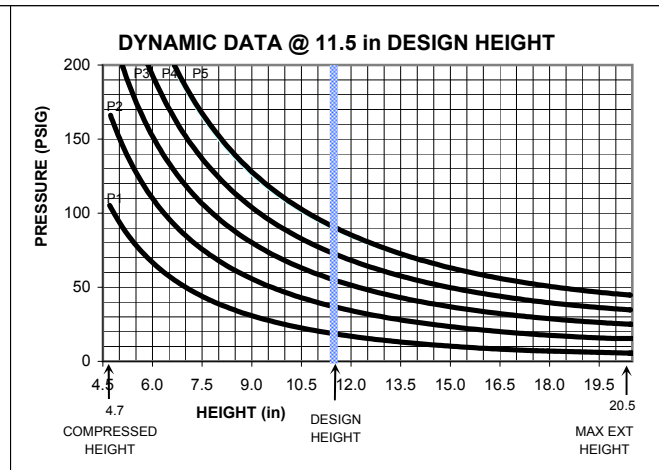
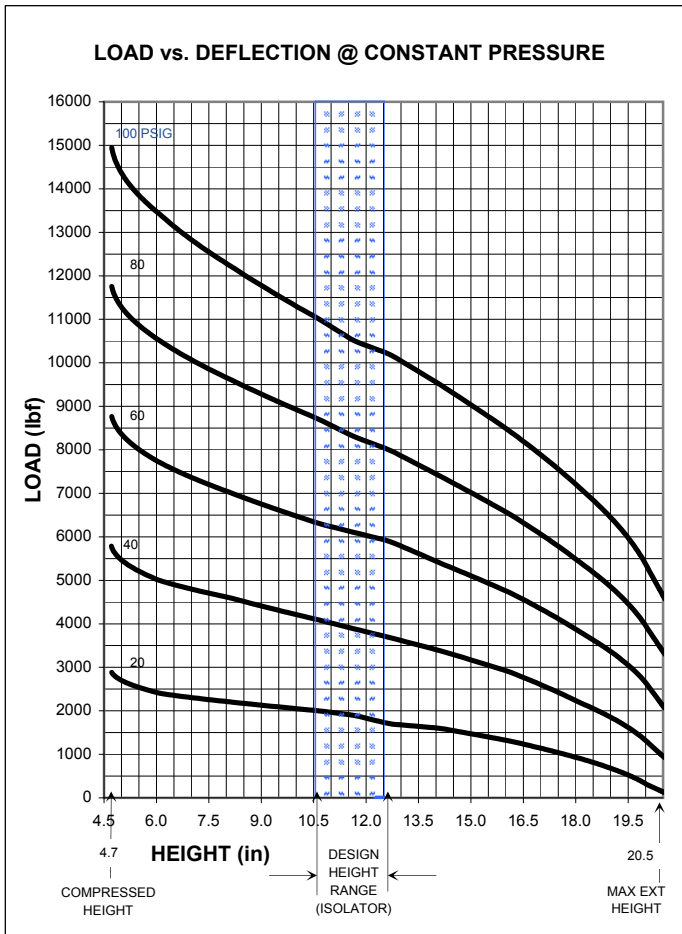

****NOTE: MAXIMUM INFLATION PRESSURE IS 100 PSIG. MAXIMUM JOUNCE PRESSURE IS 200 PSIG. IF YOUR APPLICATION WILL EXCEED THESE LIMITS, CONSULT A GOODYEAR ENGINEERED PRODUCTS AIR SPRINGS REPRESENTATIVE FOR APPLICATION ASSISTANCE.**

CONSTANT PRESSURE CHARACTERISTICS

Assembly Height (in)	Volume @ 100 PSIG (in ³)	Nominal Force (lb)				
		@ 20 PSIG	@ 40 PSIG	@ 60 PSIG	@ 80 PSIG	@ 100 PSIG
		20.5	2140	100	900	2000
20.0	2120	300	1300	2600	3900	5300
18.0	2040	900	2200	3800	5400	7100
16.0	1920	1300	2900	4700	6500	8400
14.0	1740	1600	3400	5400	7400	9500
12.5	1590	1700	3700	5900	8000	10200
11.5	1480	1900	3900	6100	8300	10500
10.5	1330	2000	4100	6300	8700	11000
8.0	1030	2200	4600	7000	9600	12200
6.0	770	2400	5000	7700	10500	13400
4.7	510	2900	5800	8800	11800	15000

DYNAMIC CHARACTERISTICS

Design Height (in)	Load (lb)	Pressure (PSIG)	Spring Rate (lb/in)	Natural Frequency	
				cpm	Hz
12.5	2000	20	475	91	1.52
	4000	39	740	81	1.35
	6000	58	1035	78	1.30
	8000	77	1235	74	1.23
	10000	95	1445	71	1.18
11.5	2000	19	470	91	1.52
	4000	38	775	83	1.38
	6000	56	1025	78	1.30
	8000	74	1335	77	1.28
	10000	91	1540	74	1.23
10.5	2000	19	560	100	1.67
	4000	37	775	83	1.38
	6000	54	1115	81	1.35
	8000	71	1570	83	1.38
	10000	88	1830	80	1.33

The GOODYEAR (and Winged Foot Design) trademark is used by Veyance Technologies, Inc. under license from The Goodyear Tire & Rubber Company. Goodyear Engineered Products are manufactured and sourced exclusively by Veyance Technologies, Inc. or its affiliates. The following trademarks are licensed to Veyance Technologies, Inc. by The Goodyear Tire & Rubber Company, including Compass, Eagle Pd, Flexten, Gatorback and GY Metric. ©2008 Veyance Technologies, Inc. All Rights Reserved.



3B15-375

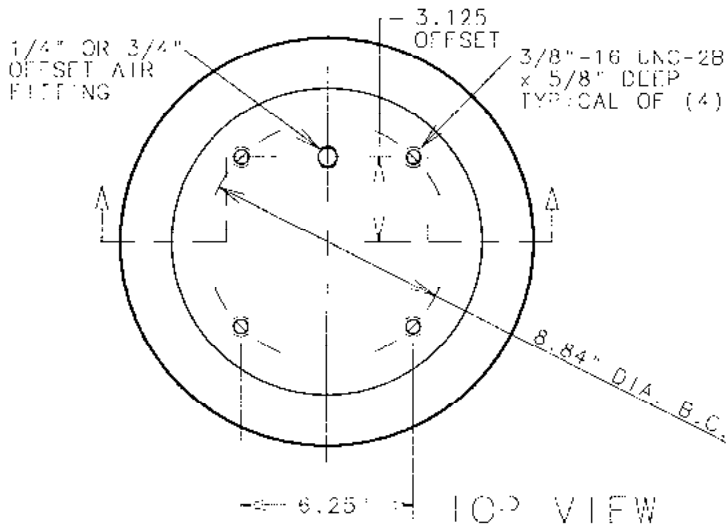

ASSEMBLY NUMBER	ELASTOMER	AIR FITTING	BUMPER INCLUDED
3B15-375	NAT. RUBBER	1/4"-18 NPT ^o OFFSET 3.125"	NO
3B15-376	NAT. RUBBER	1/4"-18 NPT ^o OFFSET 3.125"	YES
3B15-377	NAT. RUBBER	3/4"-14 NPT ^o OFFSET 3.125"	NO
3B15-378	NAT. RUBBER	3/4"-14 NPT ^o OFFSET 3.125"	YES
5/8933377 EX-MEMBER ONLY	NAT. RUBBER	----	----

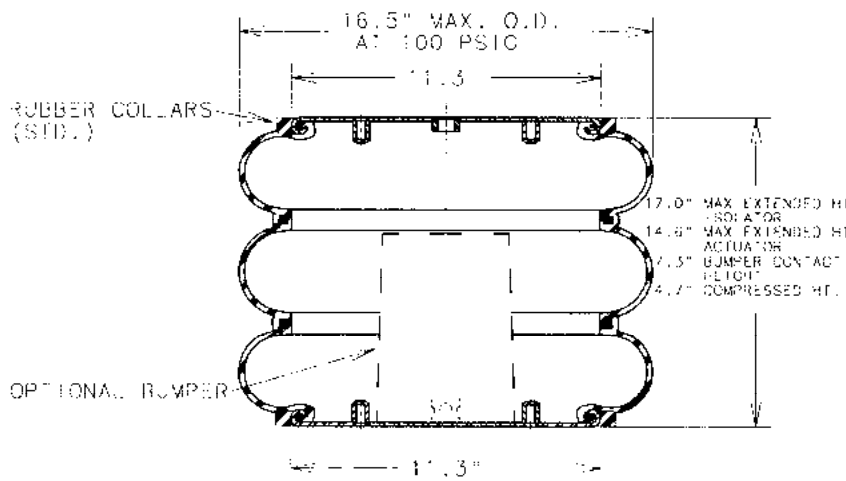

SPRING FEATURES:

- LOAD RANGE (ISOLATOR).....2200-12800 lb
- DEF ON FLIGHT RANGE (ISOLATOR)....10.5-12.5 in
- USEABLE STROKE w/o BUMPER (ACTUATOR)....9.9 in
- USEABLE STROKE WITH BUMPER (ACTUATOR)....7.5 in
- ASSEMBLY WEIGHT.....23.0 lb
- FORCE TO COMPRESS AT 0 PSIG (APPROX.)....30 lb
- NOMINAL FREE STANDING HT. AT 0 PSIG....5.3 in

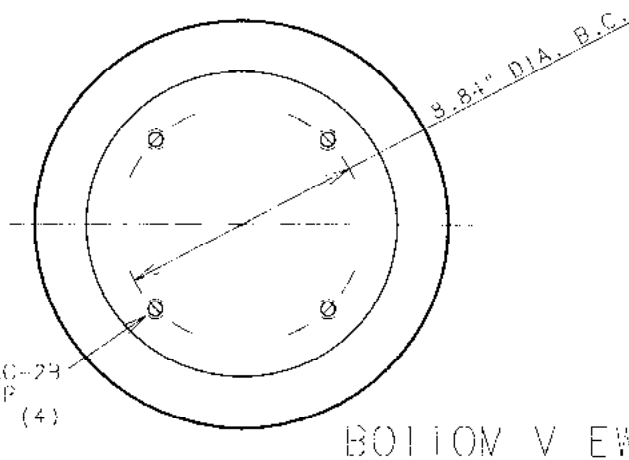

RECOMMENDED MAX. TORQUE VALUES

3/8"-16 UNC BLIND TAP TYP. OF (8)	1/4"-18 UNC AIR FITTING	3/4"-14 UNC AIR FITTING
300 in-lb 25 ft-lb	240 in-lb 20 ft-lb	240 in-lb 20 ft-lb

NOTE: SEE GUIDELINES FOR PROPER APPLICATION OF THIS PRODUCT

LOAD vs. DEFLECTION @ CONSTANT PRESSURE

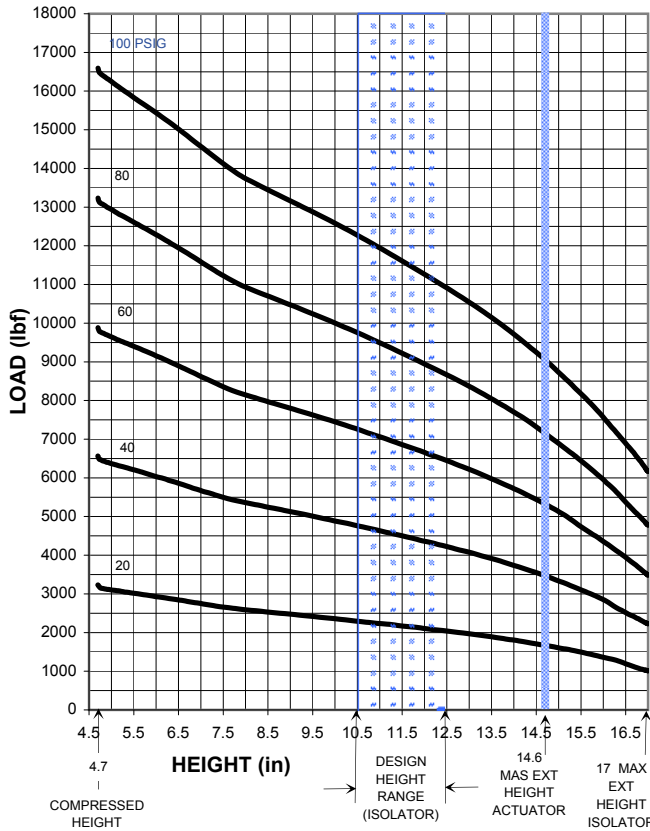

DYNAMIC DATA @ 13.0 in DESIGN HEIGHT

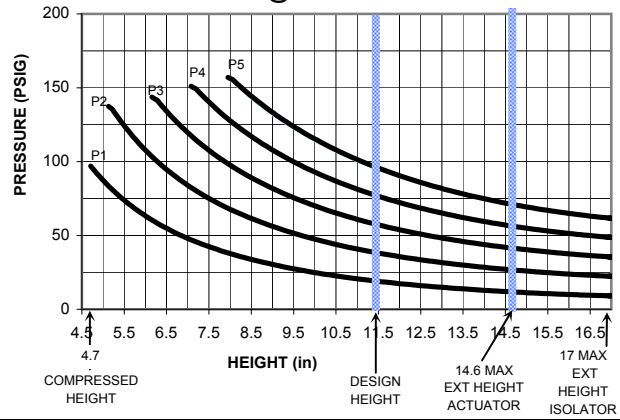

DYNAMIC DATA @ 13.0 in DESIGN HEIGHT

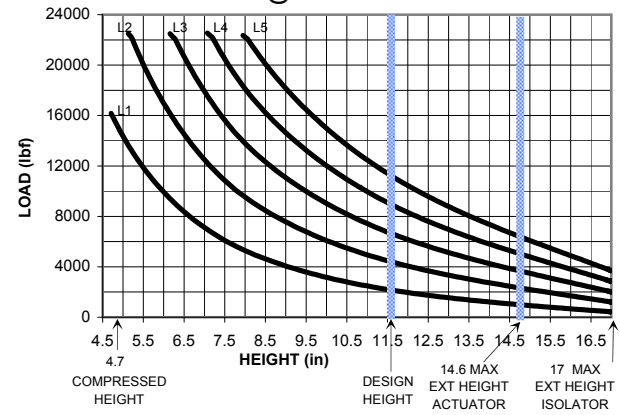

****NOTE: MAXIMUM INFLATION PRESSURE IS 100 PSIG. MAXIMUM JOUNCE PRESSURE IS 200 PSIG. IF YOUR APPLICATION WILL EXCEED THESE LIMITS, CONSULT A GOODYEAR ENGINEERED PRODUCTS AIR SPRINGS REPRESENTATIVE FOR APPLICATION ASSISTANCE.**

CONSTANT PRESSURE CHARACTERISTICS

Assembly Height (in)	Volume @ 100 PSIG (in ³)	Nominal Force (lb)				
		@ 20 PSIG	@ 40 PSIG	@ 60 PSIG	@ 80 PSIG	@ 100 PSIG
		17.0	1997	1000	2200	3400
16.0	1915	1300	2800	4400	5900	7600
15.0	1824	1600	3400	5100	7000	8800
14.6	1784	1700	3500	5400	7100	9200
14.0	1725	1900	3800	5800	7400	9800
12.5	1565	2200	4400	6600	8900	11200
11.5	1450	2300	4700	7100	9500	12000
10.5	1332	2500	5000	7600	10100	12800
9.0	1144	2700	5500	8200	10900	13700
7.0	887	3000	6000	9000	12000	15000
4.7	595	3200	6500	9700	13200	16500

DYNAMIC CHARACTERISTICS

Design Height (in)	Load (lb)	Pressure (PSIG)	Spring Rate (lb/in)	Natural Frequency	
				cpm	Hz
12.5	2300	21	495	87	1.45
	4600	42	875	82	1.37
	6900	62	1210	79	1.32
	9200	83	1585	78	1.30
11.5	2300	20	540	91	1.52
	4600	39	905	83	1.38
	6900	58	1255	80	1.33
	9200	77	1630	79	1.32
	11500	96	2010	78	1.30
10.5	2300	19	585	95	1.58
	4600	37	965	86	1.43
	6900	55	1330	83	1.38
	9200	73	1710	81	1.35
	11500	91	2090	80	1.33

The GOODYEAR (and Winged Foot Design) trademark is used by Veyance Technologies, Inc. under license from The Goodyear Tire & Rubber Company. Goodyear Engineered Products are manufactured and sourced exclusively by Veyance Technologies, Inc. or its affiliates. The following trademarks are licensed to Veyance Technologies, Inc. by The Goodyear Tire & Rubber Company, including Compass, Eagle Pd, Flexten, Gatorback and GY Metric. ©2008 Veyance Technologies, Inc. All Rights Reserved.



1R8-005

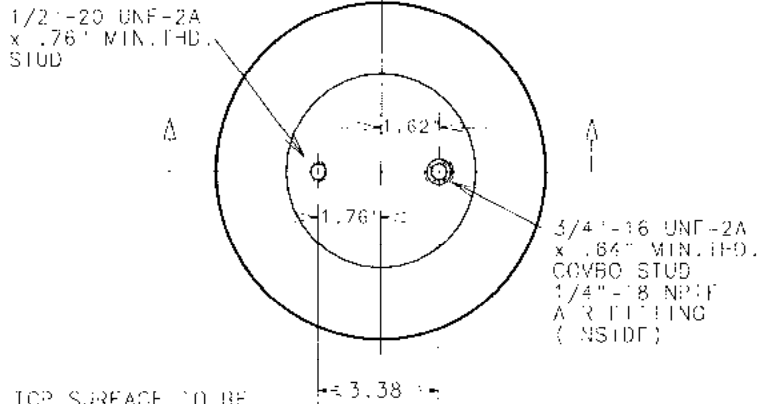

TOP SURFACE TO BE FULLY SUPPORTED BY 7.7" DIA. PLATE

TOP VIEW

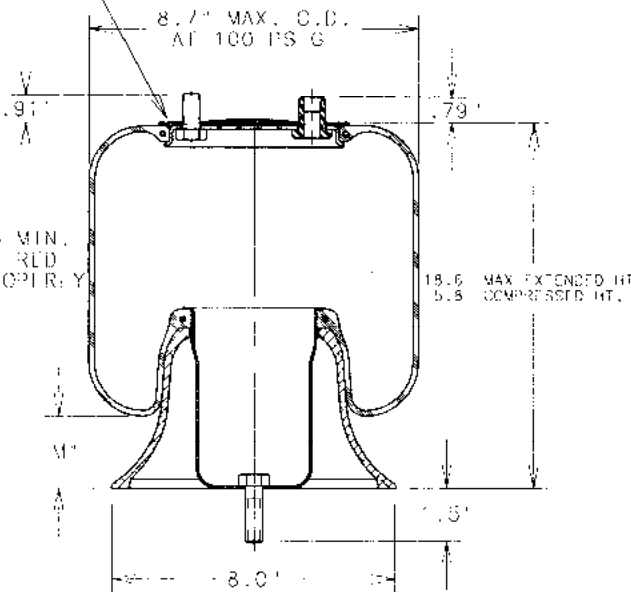

NOTE: 10 PSIG MIN. PRESSURE REQUIRED TO OPERATE PROPERLY

SIDE VIEW

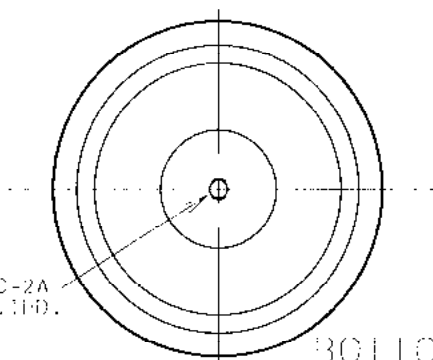

BOTTOM VIEW

ASSEMBLY NUMBER	ELASTOMER	AIR FILLING	BUMPER INCLUDED
TRB 005	NAT. RUBBER	1/4" - 18 NPTI COMBO STUD	NO

SPRING FEATURES:

- LOAD RANGE (ISOLATOR).....560-3100 lb
- DESIGN HEIGHT RANGE (ISOLATOR).....10.5-13.0 in
- USABLE STROKE (ACTUATOR).....12.8 in
- ASSEMBLY WEIGHT.....6.5 lb
- COMPOSITE PISTON

OTHER OPTIONS:

- UPPER RETAINER WITH VARIOUS HEIGHT BUMPERS
- ALTERNATE ALUMINUM PISTONS WITH DIFFERENT SPRING RATES.

RECOMMENDED MAX. TORQUE VALUES

3/4" - 16 UNF COMBO STUD	1/2" - 20 UNF STUD TYP. OF (2)	1/4" - 18 UNC AIR FILLING
500 in-lb 56 ft-lb	300 in-lb 25 ft-lb	240 in-lb 20 ft-lb

NOTE: SEE GUIDELINES FOR PROPER APPLICATION OF THIS PRODUCT

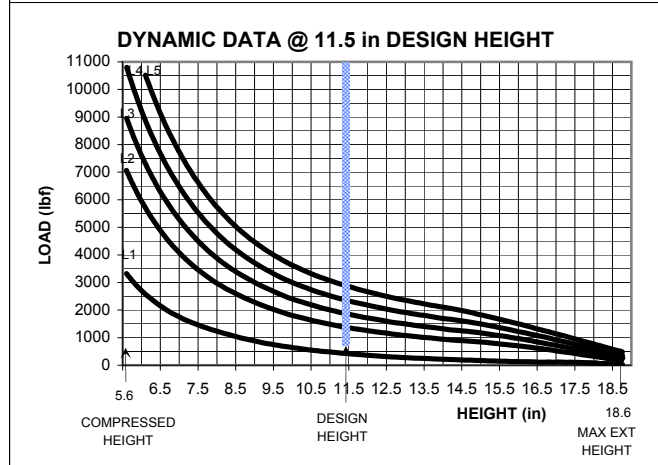
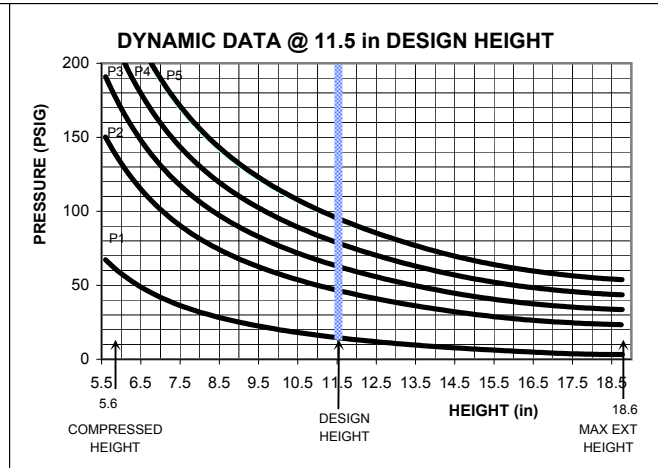
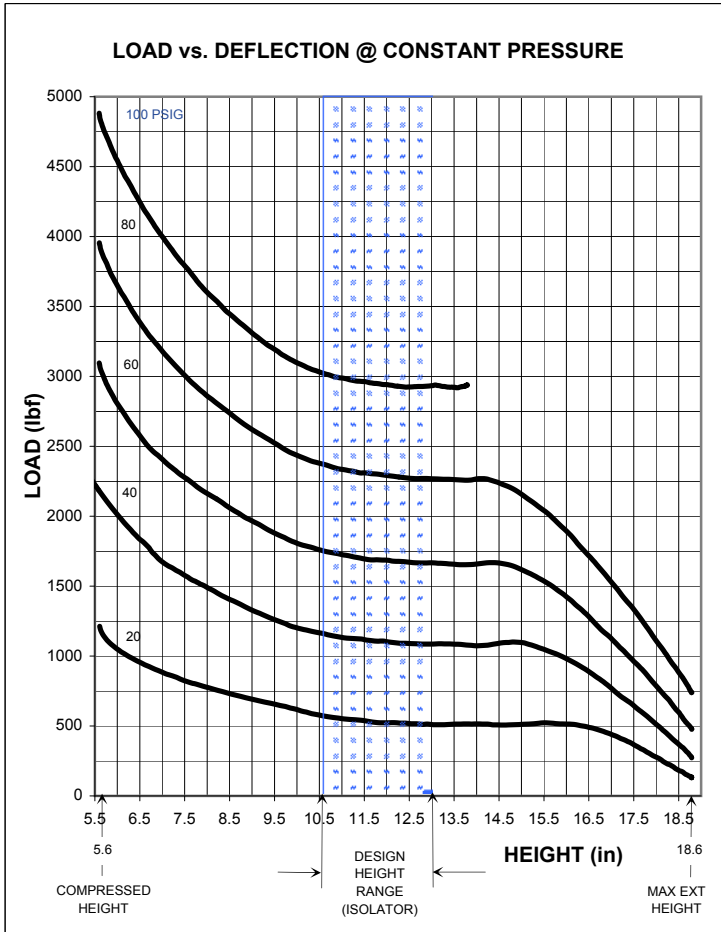

****NOTE: MAXIMUM INFLATION PRESSURE IS 100 PSIG. MAXIMUM JOUNCE PRESSURE IS 200 PSIG. IF YOUR APPLICATION WILL EXCEED THESE LIMITS, CONSULT A GOODYEAR ENGINEERED PRODUCTS AIR SPRINGS REPRESENTATIVE FOR APPLICATION ASSISTANCE.**

CONSTANT PRESSURE CHARACTERISTICS

Assembly Height (in)	Meniscus Height "M" Dim. @ 100 PSIG (in)	Volume @ 100 PSIG (in ³)	Nominal Force (lb)				
			@ 20 PSIG	@ 40 PSIG	@ 60 PSIG	@ 80 PSIG	@ 100 PSIG
18.6	5.4	562	210	380	640	900	--
17.0	4.7	529	480	850	1200	1600	--
16.0	4.4	502	560	1050	1500	2000	--
14.5	3.8	458	540	1150	1700	2300	--
13.0	3.1	410	560	1100	1700	2300	3000
11.5	2.3	363	580	1150	1700	2400	3000
10.5	1.7	332	640	1200	1800	2500	3100
9.0	1.1	286	800	1400	2000	2700	3400
7.0	0.5	219	1100	1800	2500	3300	4200
5.6	0.3	177	1500	2400	3200	4100	5000

DYNAMIC CHARACTERISTICS

Design Height (in)	Load (lb)	Pressure (PSIG)	Spring Rate (lb/in)	Natural Frequency	
				cpm	Hz
13.0	500	17	100	85	1.42
	1500	51	205	70	1.17
	2000	68	250	67	1.12
	2500	84	275	63	1.05
11.5	3000	100	330	62	1.03
	500	17	125	93	1.55
	1500	50	250	77	1.28
	2000	67	310	74	1.23
10.5	2500	83	350	71	1.18
	3000	100	430	70	1.17
	500	16	185	113	1.88
	1500	49	335	89	1.48
	2000	65	390	83	1.38
10.5	2500	81	465	81	1.35
	3000	97	545	80	1.33

The GOODYEAR (and Winged Foot Design) trademark is used by Veyance Technologies, Inc. under license from The Goodyear Tire & Rubber Company. Goodyear Engineered Products are manufactured and sourced exclusively by Veyance Technologies, Inc. or its affiliates. The following trademarks are licensed to Veyance Technologies, Inc. by The Goodyear Tire & Rubber Company, including Compass, Eagle Pd, Flexten, Gatorback and GY Metric. ©2008 Veyance Technologies, Inc. All Rights Reserved.



1R8-009

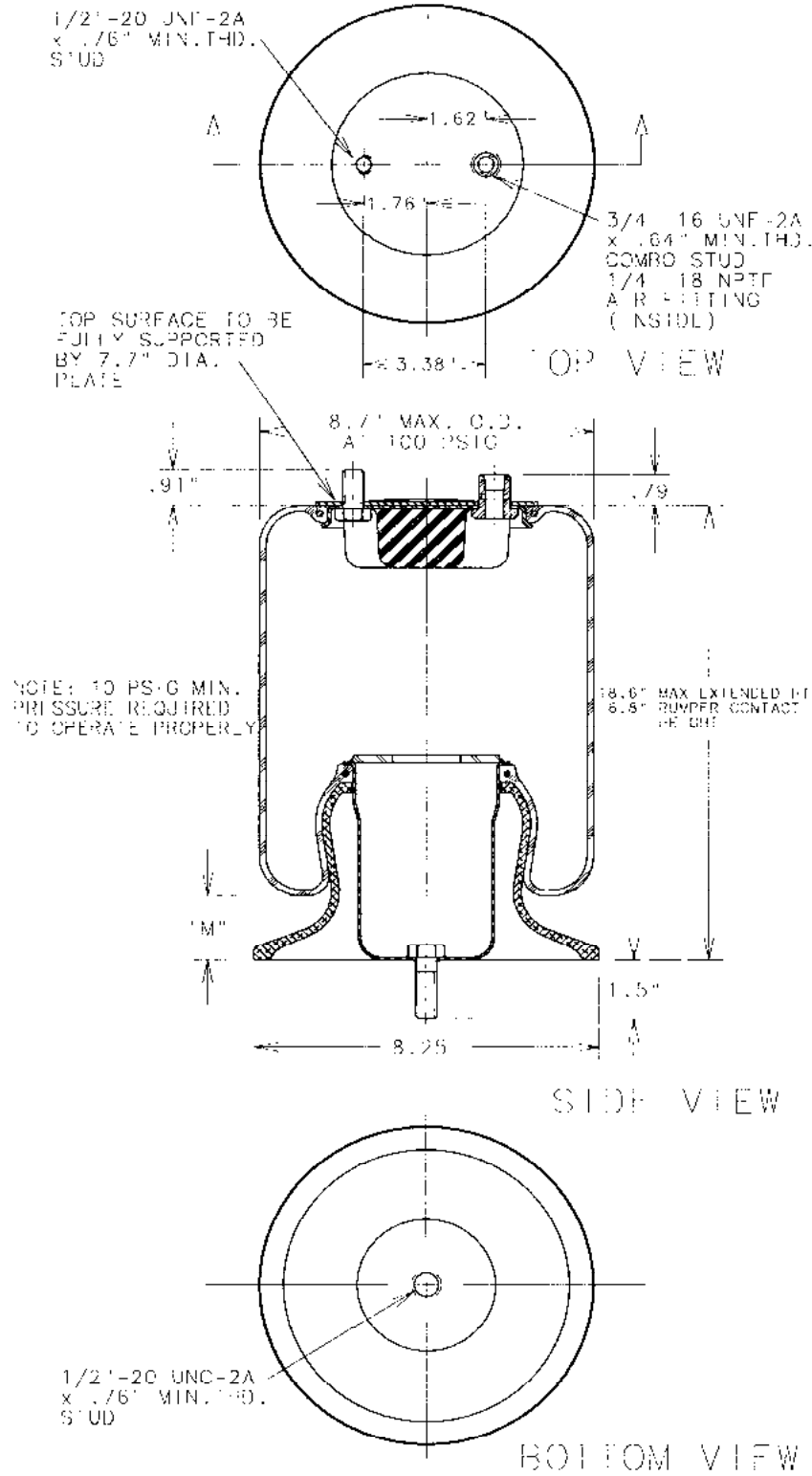

ASSEMBLY NUMBER	ELASTOMER	AIR FITTING	BUMPER INCLUDED
1R8-009	NAT. RUBBER	1/4"-18 NPTF COMBO STUD	YES

SPRING FEATURES:

- LOAD RANGE (ISOLATOR).....480-2700 Lb
- DESIGN FREQUENCY RANGE (ISOLATOR)....10.5-13.0 Hz
- USEABLE STROKE (ACTUATOR).....11.8 in
- ASSEMBLY WEIGHT.....8.2 Lb
- ALUMINUM PISTON

OTHER OPTIONS:

- UPPER RETAINER WITH NO BUMPER OR ALTERNATE BUMPER
- COMPOSITE PISTON WITH DIFFERENT SPRING RATE

RECOMMENDED MAX. TORQUE VALUES

3/4"-16 UNF COMBO STUD	1/2"-20 UNF STUD TYP. OF (2)	1/4"-18 UNF AIR FITTING
600 in-lb 50 ft-lb	300 in-lb 25 ft-lb	240 in-lb 20 ft-lb

NOTE: SEE GUIDELINES FOR PROPER APPLICATION OF THIS PRODUCT

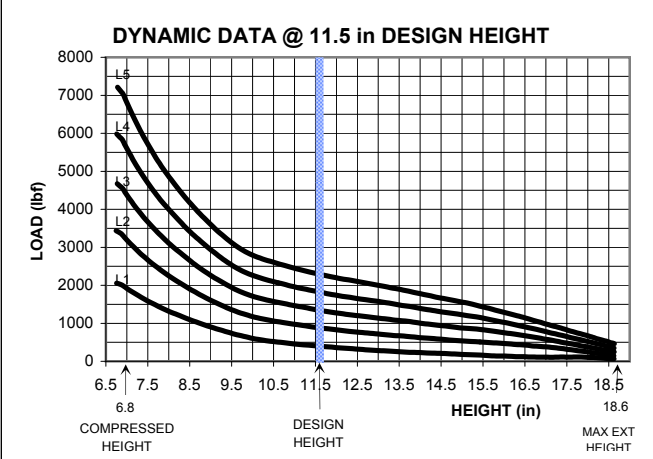
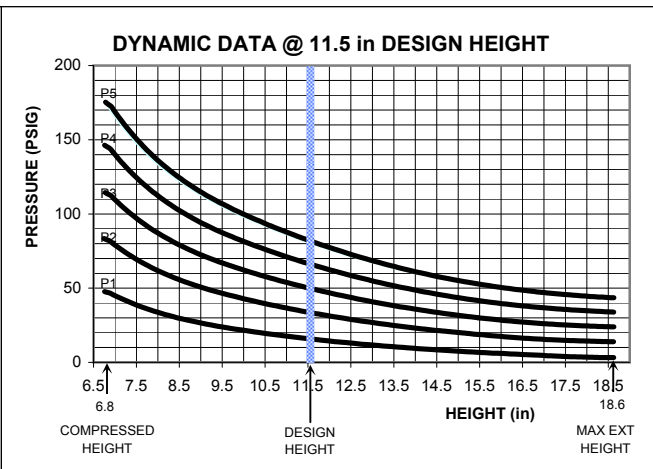
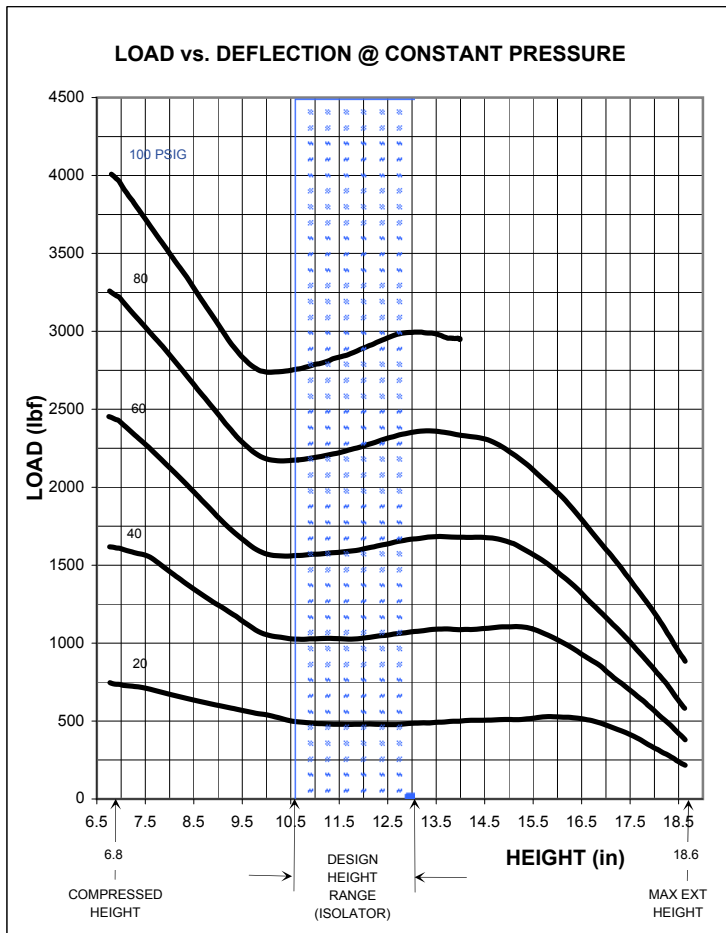

****NOTE: MAXIMUM INFLATION PRESSURE IS 100 PSIG. MAXIMUM JOUNCE PRESSURE IS 200 PSIG. IF YOUR APPLICATION WILL EXCEED THESE LIMITS, CONSULT A GOODYEAR ENGINEERED PRODUCTS AIR SPRINGS REPRESENTATIVE FOR APPLICATION ASSISTANCE.**

CONSTANT PRESSURE CHARACTERISTICS

Assembly Height (in)	Meniscus Height "M" Dim. @ 100 PSIG (in)	Volume @ 100 PSIG (in ³)	Nominal Force (lb)				
			@ 20 PSIG	@ 40 PSIG	@ 60 PSIG	@ 80 PSIG	@ 100 PSIG
18.6	5.6	533	200	360	560	850	--
17.0	4.5	501	440	800	1150	1600	--
16.0	4.3	474	520	1000	1450	1900	--
14.5	3.9	429	500	1050	1700	2300	--
13.0	3.3	381	480	1050	1700	2300	2900
11.5	2.1	334	460	1000	1700	2200	2800
10.5	1.4	305	480	1000	1600	2100	2700
9.0	0.9	264	700	1150	1800	2300	2900
8.0	0.6	235	700	1450	2200	2700	3400
6.8	0.5	196	750	1600	2500	3200	3900

DYNAMIC CHARACTERISTICS

Design Height (in)	Load (lb)	Pressure (PSIG)	Spring Rate (lb/in)	Natural Frequency	
				cpm	Hz
13.0	500	18	80	74	1.23
	1000	34	125	67	1.12
	1500	51	185	66	1.10
	2000	67	240	65	1.08
11.5	2500	81	290	64	1.07
	500	18	105	87	1.45
	1000	36	150	72	1.20
	1500	53	185	66	1.10
10.5	2000	70	235	64	1.07
	2500	86	250	59	0.98
	500	19	150	102	1.70
	1000	37	180	80	1.33
10.5	1500	54	205	70	1.17
	2000	71	260	68	1.13
	2500	89	285	63	1.05

The GOODYEAR (and Winged Foot Design) trademark is used by Veyance Technologies, Inc. under license from The Goodyear Tire & Rubber Company. Goodyear Engineered Products are manufactured and sourced exclusively by Veyance Technologies, Inc. or its affiliates. The following trademarks are licensed to Veyance Technologies, Inc. by The Goodyear Tire & Rubber Company, including Compass, Eagle Pd, Flexten, Gatorback and GY Metric. ©2008 Veyance Technologies, Inc. All Rights Reserved.



1R9-003

1/2"-20 UNF 2A
x .76" MIN. THD.
STUD

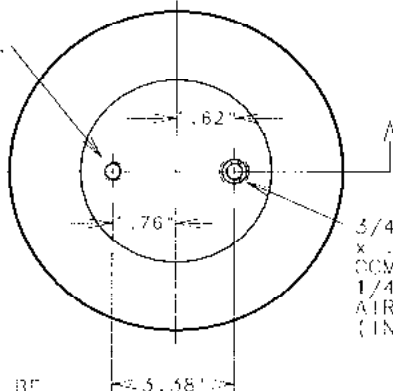

3/4"-16 UNF 2A
x .64" MIN. THD.
COMBO STUD
1/4"-18 NPTF
AIR FITTING
(INSIDE)

TOP SURFACE TO BE
FULLY SUPPORTED
BY 8.5" DIA.
PLATE

TOP VIEW

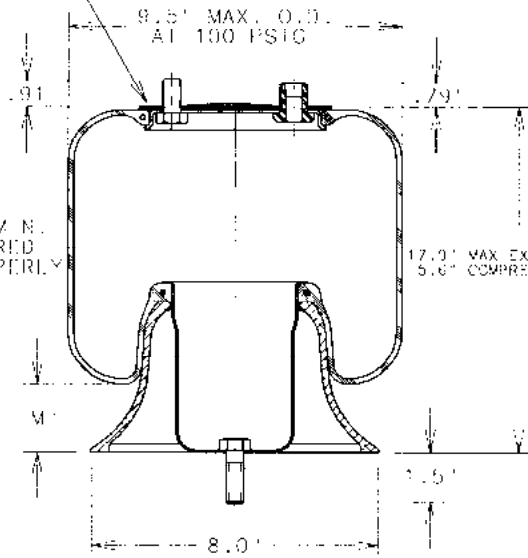

NOTE: 10 PSIG MIN.
PRESSURE REQUIRED
TO OPERATE PROPERLY

17.0" MAX EXTENDED HT.
5.6" COMPRESSED HT.

SIDE VIEW

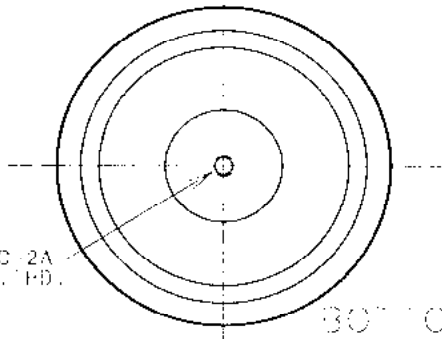

3/8"-16 UNC 2A
x .79" MIN. THD.
STUD

BOTTOM VIEW

ASSEMBLY NUMBER	ELASTOMER	AIR FITTING	BUMPER PROVIDED
1R9-003	NAT. RUBBER	1/4"-18 NPTF COMBO STUD	NO

SPRING FEATURES:

- LOAD RANGE (ISOLATOR).....560-3700 lb
- DESIGN HEIGHT RANGE (ISOLATOR).....8.0-12.0"
- USABLE STROKE (ADJUSTER).....12.3"
- ASSEMBLY WEIGHT.....6.4 lb
- COMPOSITE PISTON

OTHER OPTIONS:

- UPPER RETAINER WITH VARIOUS HEIGHT BUMPERS
- ALTERNATE ALUMINUM PISTONS WITH DIFFERENT SPRING RATE.

RECOMMENDED MAX. TORQUE VALUES

3/4"-16 UNF COMBO STUD	1/2"-20 UNF TOP STUD	3/8"-16 UNC BOTTOM STUD	1/4"-18 UNC AIR FITTING
600 in-lb 65 ft-lb	500 in-lb 25 ft-lb	500 in-lb 25 ft-lb	240 in-lb 20 ft-lb

NOTE: SEE GUIDELINES FOR PROPER APPLICATION OF THIS PRODUCT

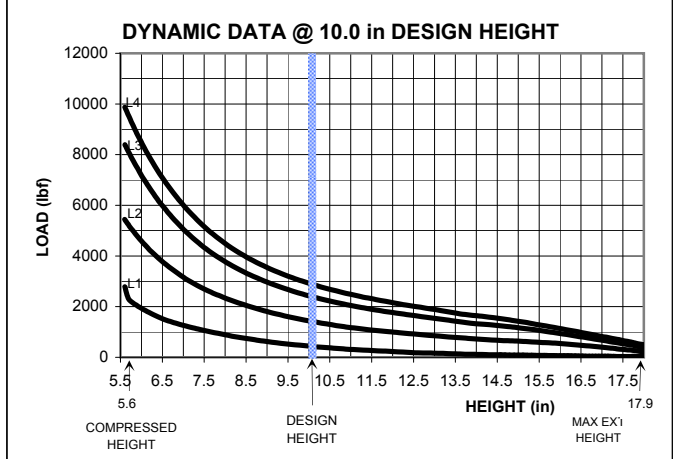
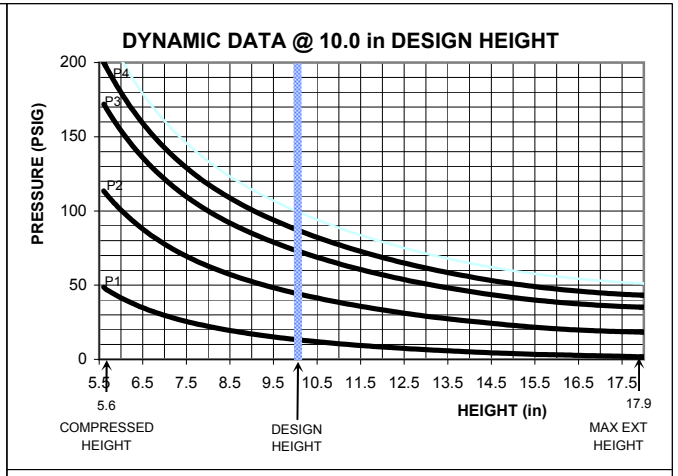
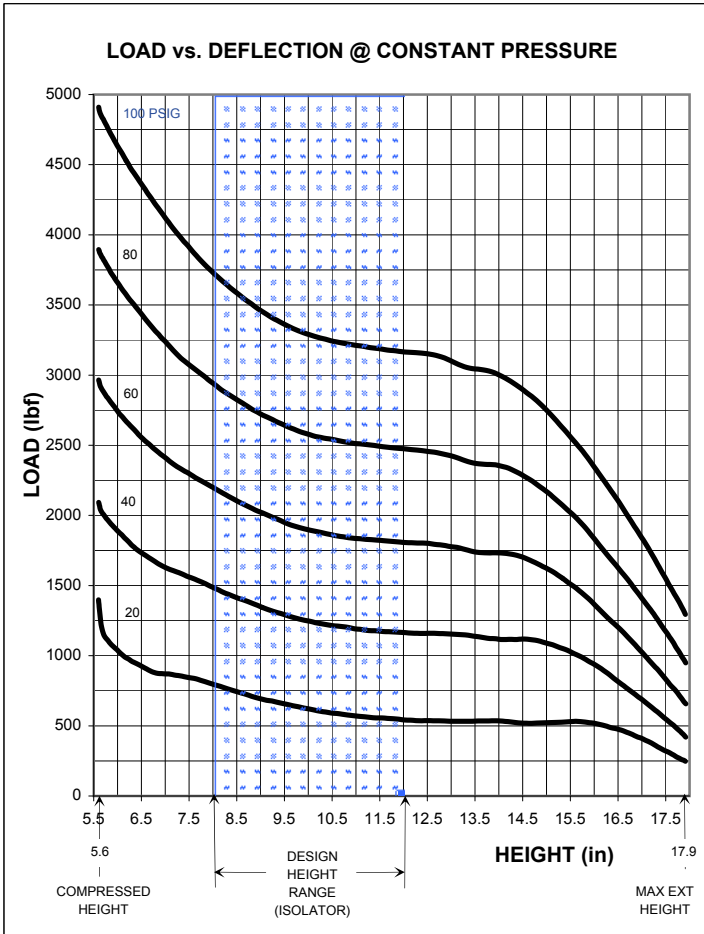

****NOTE: MAXIMUM INFLATION PRESSURE IS 100 PSIG. MAXIMUM JOUNCE PRESSURE IS 200 PSIG. IF YOUR APPLICATION WILL EXCEED THESE LIMITS, CONSULT A GOODYEAR ENGINEERED PRODUCTS AIR SPRINGS REPRESENTATIVE FOR APPLICATION ASSISTANCE.**

CONSTANT PRESSURE CHARACTERISTICS

Assembly Height (in)	Meniscus Height "M" Dim. @ 100 PSIG (in)	Volume @ 100 PSIG (in ³)	Nominal Force (lb)				
			@ 20 PSIG	@ 40 PSIG	@ 60 PSIG	@ 80 PSIG	@ 100 PSIG
17.9	5.9	610	220	400	640	900	1250
17.0	5.4	592	400	680	1000	1400	1800
16.0	4.8	567	450	900	1350	1800	2300
14.0	3.8	504	540	1100	1700	2300	3000
12.0	2.8	434	560	1150	1800	2500	3200
10.0	1.7	366	600	1200	1900	2600	3300
8.0	0.9	297	800	1500	2200	2900	3700
7.0	0.5	260	900	1600	2400	3200	4100
6.0	0.3	222	1050	1900	2700	3700	4600
5.6	0.2	206	1150	2000	2900	3900	4900

DYNAMIC CHARACTERISTICS

Design Height (in)	Load (lb)	Pressure (PSIG)	Spring Rate (lb/in)	Natural Frequency	
				cpm	Hz
12.0	500	17	100	85	1.42
	1500	48	215	71	1.18
	2500	78	330	68	1.13
	3000	92	370	66	1.10
10.0	500	15	165	107	1.78
	1500	47	295	83	1.38
	2500	76	440	78	1.30
	3000	90	515	77	1.28
8.0	500	18	210	121	2.02
	1500	39	435	102	1.70
	2500	67	675	98	1.63
	3000	80	785	96	1.60
	3500	93	895	95	1.58

The GOODYEAR (and Winged Foot Design) trademark is used by Veyance Technologies, Inc. under license from The Goodyear Tire & Rubber Company. Goodyear Engineered Products are manufactured and sourced exclusively by Veyance Technologies, Inc. or its affiliates. The following trademarks are licensed to Veyance Technologies, Inc. by The Goodyear Tire & Rubber Company, including Compass, Eagle Pd, Flexten, Gatorback and GY Metric. ©2008 Veyance Technologies, Inc. All Rights Reserved.



1R9-009

1/2"-20 UNF-2A
x .76" MIN. THD.
STUD

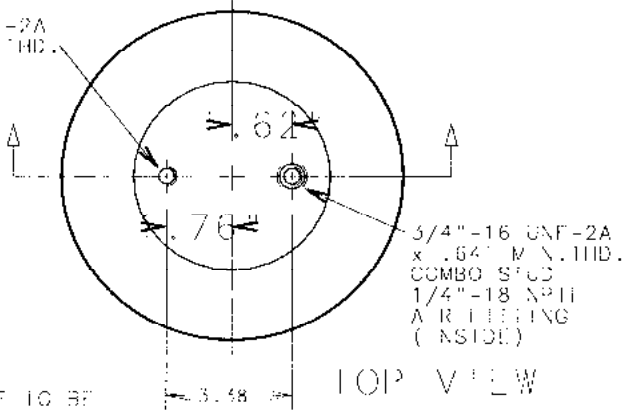

TOP VIEW

TOP SURFACE TO BE FULLY SUPPORTED BY 8.5" DIA. PLATE

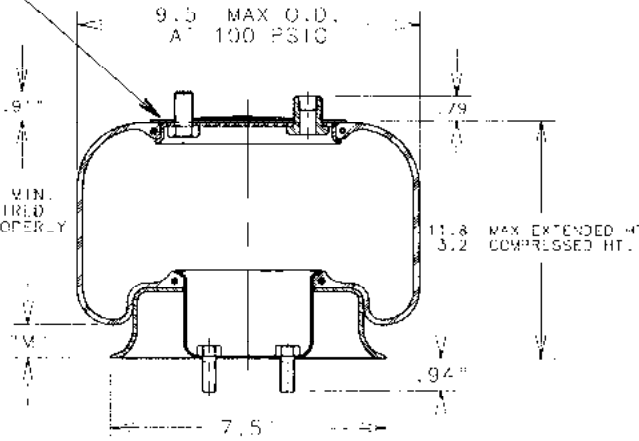

SIDE VIEW

1/2"-20 UNF-2A
x .76" MIN. THD.
STUD, TYPICAL
OF (2)

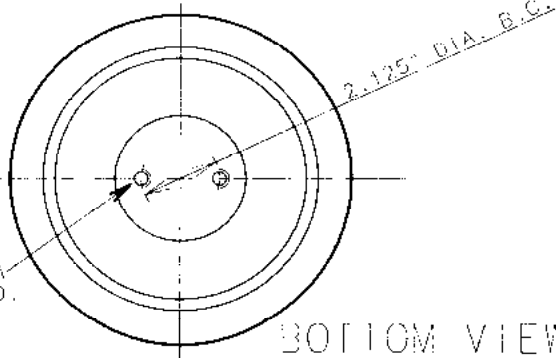

BOTTOM VIEW

ASSEMBLY NUMBER	ELASTOMER	AIR FITTING	BLINDER INCLUDED
1R9-009	NAT. RUBBER	1/4"-18 UNF COMBO STUD	NO

SPRING FEATURES:

- LOAD RANGE (ISOLATOR).....800-4400 lb
- DESIGN HEIGHT RANGE (ISOLATOR).....6.0-7.5 in
- USABLE STROKE (ACTUATOR).....8.6 in
- ASSEMBLY WEIGHT.....6.0 lb
- STEEL PISTON

RECOMMENDED MAX. TORQUE VALUES

3/4"-16 UNF COMBO STUD	1/2"-20 UNF STUD OF (5)	1/4"-18 UNC AIR FITTING
820 in lb 53 ft-lb	330 in lb 25 ft-lb	240 in lb 20 ft-lb

NOTE: SEE GUIDELINES FOR PROPER APPLICATION OF THIS PRODUCT

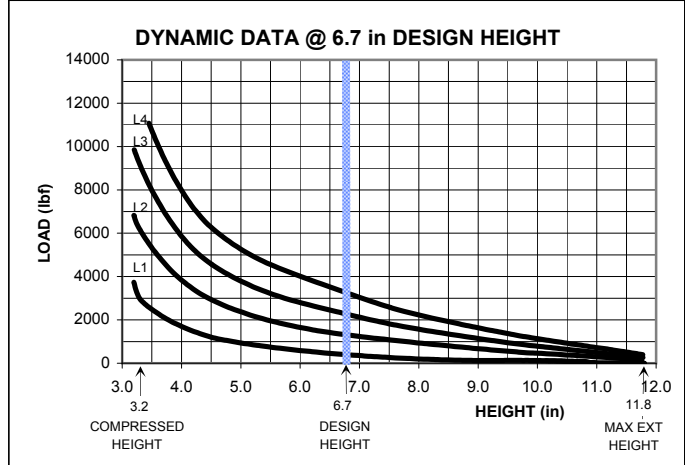
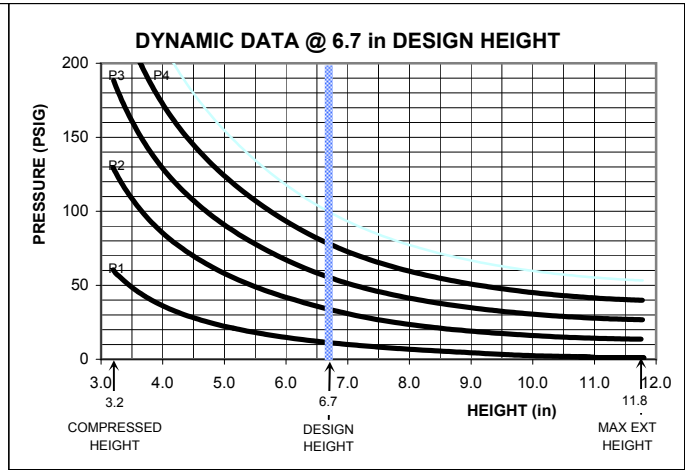
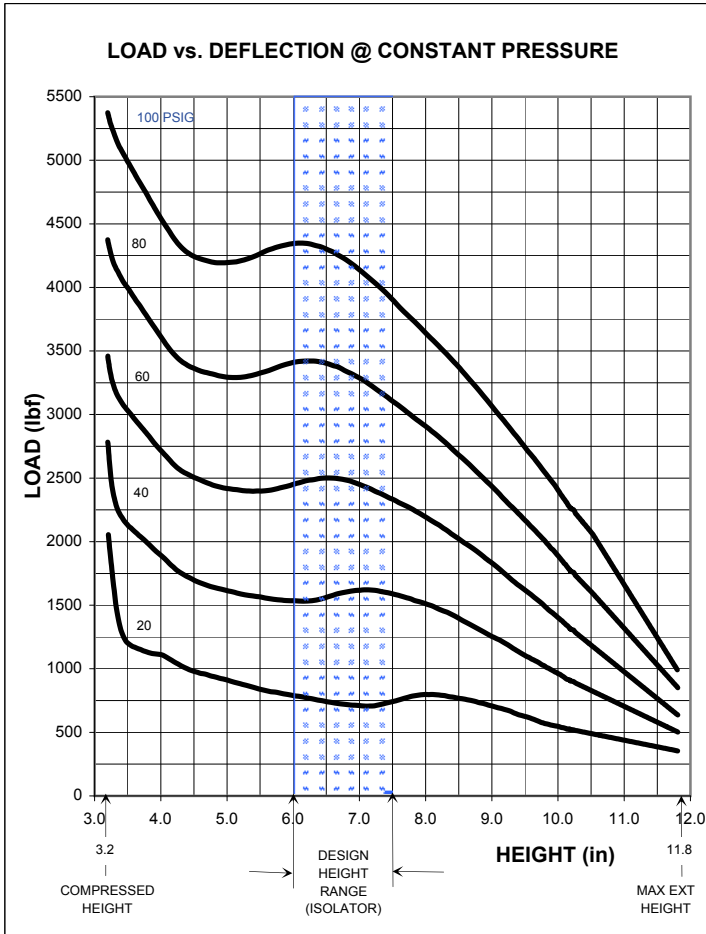

****NOTE: MAXIMUM INFLATION PRESSURE IS 100 PSIG. MAXIMUM JOUNCE PRESSURE IS 200 PSIG. IF YOUR APPLICATION WILL EXCEED THESE LIMITS, CONSULT A GOODYEAR ENGINEERED PRODUCTS AIR SPRINGS REPRESENTATIVE FOR APPLICATION ASSISTANCE.**

CONSTANT PRESSURE CHARACTERISTICS

Assembly Height (in)	Meniscus Height "M" Dim. @ 100 PSIG (in)	Volume @ 100 PSIG (in ³)	Nominal Force (lb)				
			@ 20 PSIG	@ 40 PSIG	@ 60 PSIG	@ 80 PSIG	@ 100 PSIG
11.8	2.5	436	180	330	500	700	900
10.5	2.3	388	460	750	1150	1500	2000
9.5	2.1	358	640	1100	1600	2100	2700
8.5	2.0	325	800	1400	2000	2700	3300
7.5	1.9	287	800	1600	2400	3100	3900
6.7	1.8	257	700	1700	2600	3400	4300
6.0	1.7	228	800	1500	2500	3500	4400
5.0	0.5	181	900	1600	2400	3300	4400
4.0	0.9	135	1150	1900	2700	3600	4600
3.2	0.0	100	1850	2600	3400	4400	5300

DYNAMIC CHARACTERISTICS

Design Height (in)	Load (lb)	Pressure (PSIG)	Spring Rate (lb/in)	Natural Frequency	
				cpm	Hz
7.5	500	14	185	114	1.90
	1500	37	455	103	1.72
	2500	62	790	106	1.77
6.7	500	13	230	128	2.13
	1500	36	430	101	1.68
	2500	58	740	102	1.70
6.0	500	11	280	140	2.33
	1500	39	525	111	1.85
	2500	61	685	98	1.63
	3500	82	920	96	1.60

The GOODYEAR (and Winged Foot Design) trademark is used by Veyance Technologies, Inc. under license from The Goodyear Tire & Rubber Company. Goodyear Engineered Products are manufactured and sourced exclusively by Veyance Technologies, Inc. or its affiliates. The following trademarks are licensed to Veyance Technologies, Inc. by The Goodyear Tire & Rubber Company, including Compass, Eagle Pd, Flexten, Gatorback and GY Metric. ©2008 Veyance Technologies, Inc. All Rights Reserved.



1R10-089

1/2" -20 UNF-2A
x .70" MIN. THD.
STUD

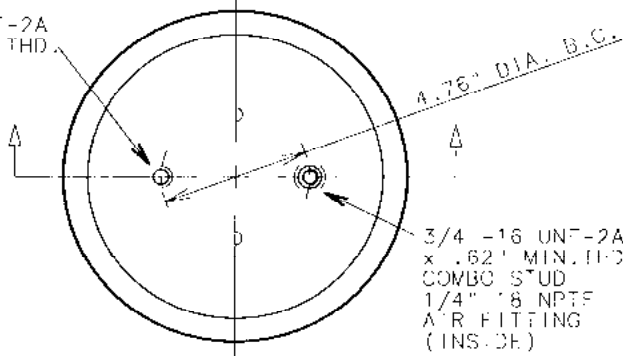

TOP VIEW

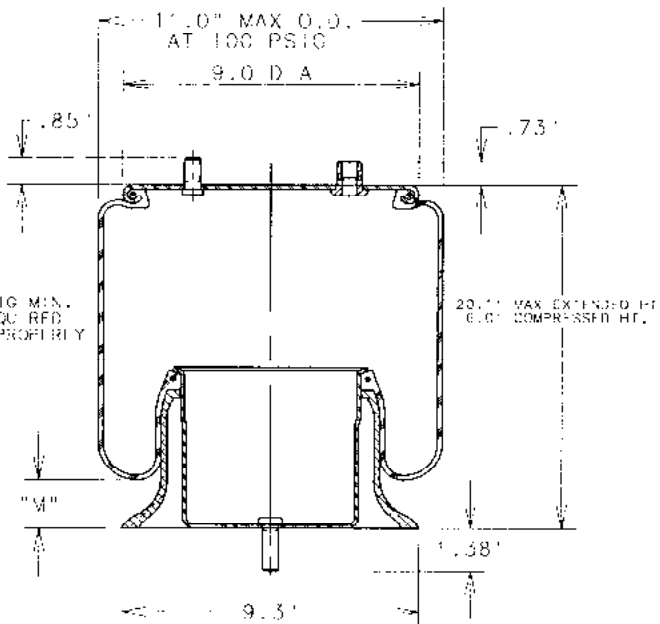

NOTE: 10 PSIG MIN.
PRESSURE REQU. REQD.
TO OPERATE PROPERLY

20.0\"/>

SIDE VIEW

THIS SURFACE TO
BE FULLY SUPPORTED
TO FULL PISTON
BASE DIAMETER

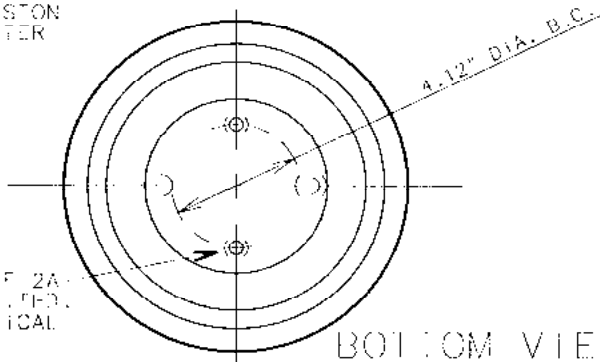

1/2" -20 UNF-2A
x .70" MIN. THD.
STUD, TYPICAL
OF (2)

BOTTOM VIEW

ASSEMBLY NUMBER	ELASTOMER	AIR FITTING	BUMPER INCLUDED
1R10-089	NAT. RUBBLR	1/4" -18 NPTF COMBO STUD	NO

SPRING FEATURES:

- LOAD RANGE (ISOLATOR).....1000-5700 lb
- DESIGN HEIGHT RANGE (ISOLATOR).....9.5"-10.5 in
- USEABLE STROKE (ACTUATOR).....14.1 in
- ASSEMBLY WEIGHT.....11.4 lb
- COMPOSITE POSITION

OPTIONAL OPTIONS:

- UPPER RETAINER WITH ALTERNATE BOLT LENGTHS AND SPACINGS, VARIOUS HEIGHT BUMPERS
- ALTERNATE ALUMINUM PISTONS WITH DIFFERENT SPRING RATES

RECOMMENDED MAX. TORQUE VALUES

3/4" -16 UNF COMBO STUD	1/2" -20 UNF STUD TYP. OF (3)	1/4" -18 UNC AIR FITTING
600 in-lb 50 ft-lb	300 in-lb 25 ft-lb	240 in-lb 20 ft-lb

NOTE: SEE GUIDELINES FOR PROPER APPLICATION OF THIS PRODUCT

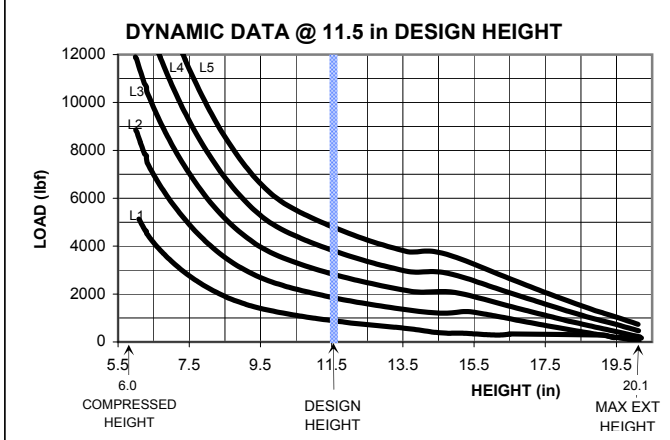
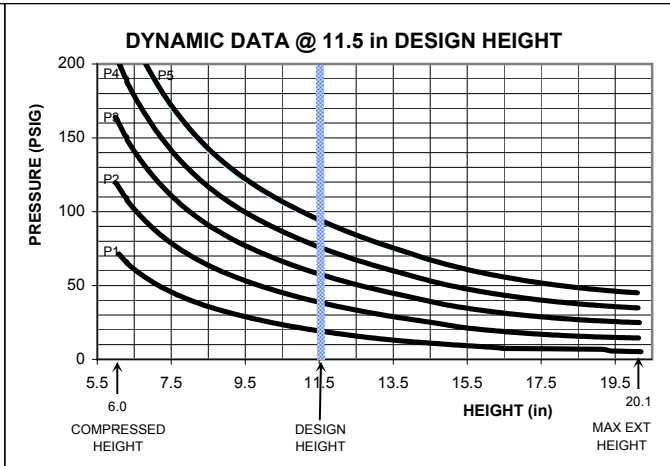
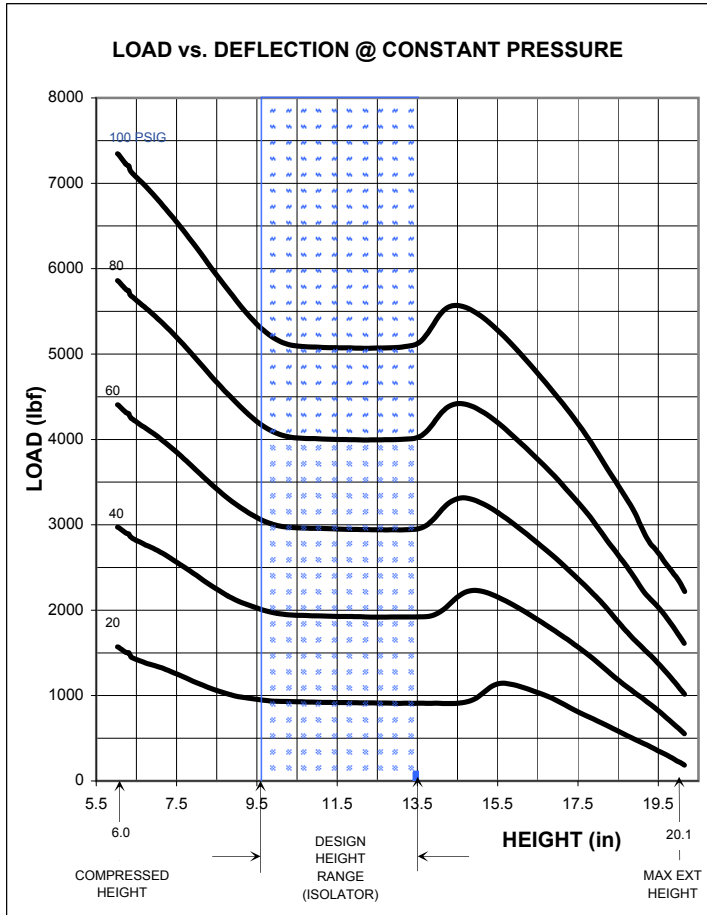

****NOTE: MAXIMUM INFLATION PRESSURE IS 100 PSIG. MAXIMUM JOUNCE PRESSURE IS 200 PSIG. IF YOUR APPLICATION WILL EXCEED THESE LIMITS, CONSULT A GOODYEAR ENGINEERED PRODUCTS AIR SPRINGS REPRESENTATIVE FOR APPLICATION ASSISTANCE.**

CONSTANT PRESSURE CHARACTERISTICS

Assembly Height (in)	Meniscus Height "M" Dim. @ 100 PSIG (in)	Volume @ 100 PSIG (in ³)	Nominal Force (lb)				
			@ 20 PSIG	@ 40 PSIG	@ 60 PSIG	@ 80 PSIG	@ 100 PSIG
20.1	4.5	1125	250	580	950	1500	2100
19.0	4.5	1080	420	900	1500	2100	2800
17.0	4.5	978	850	1600	2400	3400	4300
15.0	4.3	860	1100	2100	3200	4200	5300
13.5	3.4	766	900	1900	2900	4000	5200
11.5	2.2	651	900	1900	2900	4000	5000
9.5	1.1	544	900	1900	3000	4100	5200
8.0	0.7	462	1100	2300	3500	4800	6000
7.0	0.4	401	1300	2600	3900	5300	6700
6.0	0.4	335	1500	2900	4400	5800	7300

DYNAMIC CHARACTERISTICS

Design Height (in)	Load (lb)	Pressure (PSIG)	Spring Rate (lb/in)	Natural Frequency	
				cpm	Hz
13.5	1000	19	175	79	1.32
	2000	37	130	48	0.80
	3000	53	105	35	0.58
	4000	70	175	40	0.67
	5000	87	245	41	0.68
11.5	1000	19	205	85	1.42
	2000	38	315	75	1.25
	3000	56	410	69	1.15
	4000	74	510	67	1.12
	5000	91	600	65	1.08
9.5	1000	18	325	107	1.78
	2000	37	460	90	1.50
	3000	56	595	84	1.40
	4000	73	750	82	1.37
	5000	90	875	79	1.32

The GOODYEAR (and Winged Foot Design) trademark is used by Veyance Technologies, Inc. under license from The Goodyear Tire & Rubber Company. Goodyear Engineered Products are manufactured and sourced exclusively by Veyance Technologies, Inc. or its affiliates. The following trademarks are licensed to Veyance Technologies, Inc. by The Goodyear Tire & Rubber Company, including Compass, Eagle Pd, Flexten, Gatorback and GY Metric. ©2008 Veyance Technologies, Inc. All Rights Reserved.



1R11-028

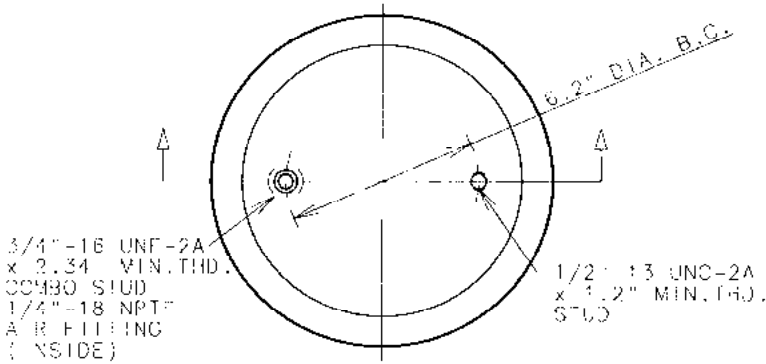

TOP VIEW

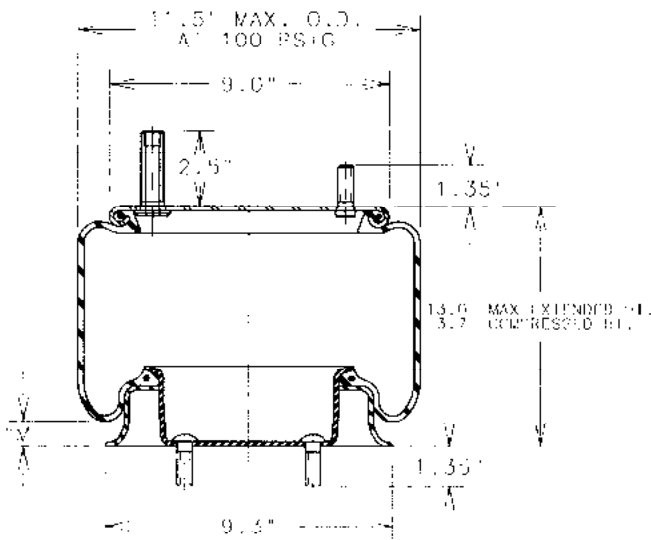

SIDE VIEW

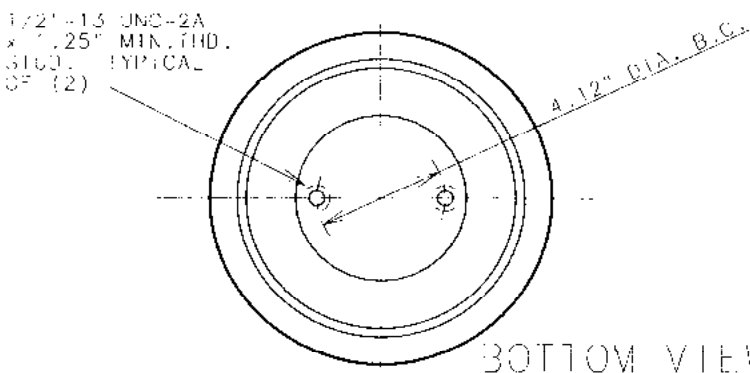

BOTTOM VIEW

ASSEMBLY NUMBER	ELASTOMER	AIR FITTING	BUMPER INCLUDED
1R11-028	NAT. RUBBER	1/4"-18 NPTF COMBO STUD	NO

SPRING FEATURES:

- LOAD RANGE (ISOLATOR).....1100-6700 lb
- DESIGN HEIGHT RANGE (ISOLATOR).....6.0-10.0 in
- USEABLE STROKE (ACTUATOR).....9.3 in
- ASSEMBLY WEIGHT.....12.8 lb
- STEEL PISTON

OTHER OPTIONS:

- METRIC ATTACHMENTS
- UPPER BEAD PLATE:
 - ALTERNATE BOLT LENGTHS AND SPACINGS
 - ALTERNATE AIR FITTING SIZES AND LOCATIONS
 - VARIOUS HEIGHT BUMPERS

RECOMMENDED MAX. TORQUE VALUES

3/4"-16 UNF COMBO STUD	1/2"-13 UNC TOP STUD	1/2"-13 UNC BOTTOM STUD TYP. OF (2)	1/4"-18 UNC AIR FITTINGS
600 in-lb 50 ft-lb	300 in-lb 25 ft-lb	300 in-lb 25 ft-lb	240 in-lb 20 ft-lb

NOTE: SEE GUIDELINES FOR PROPER APPLICATION OF THIS PRODUCT

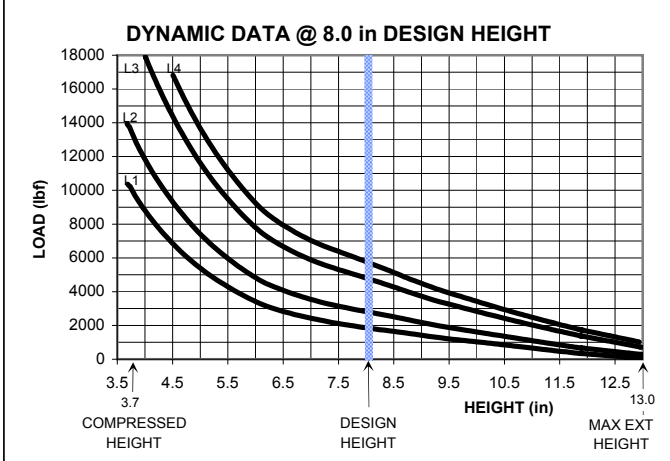
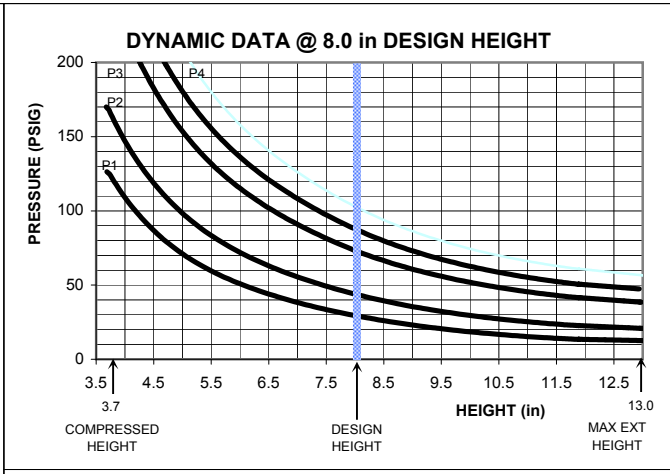
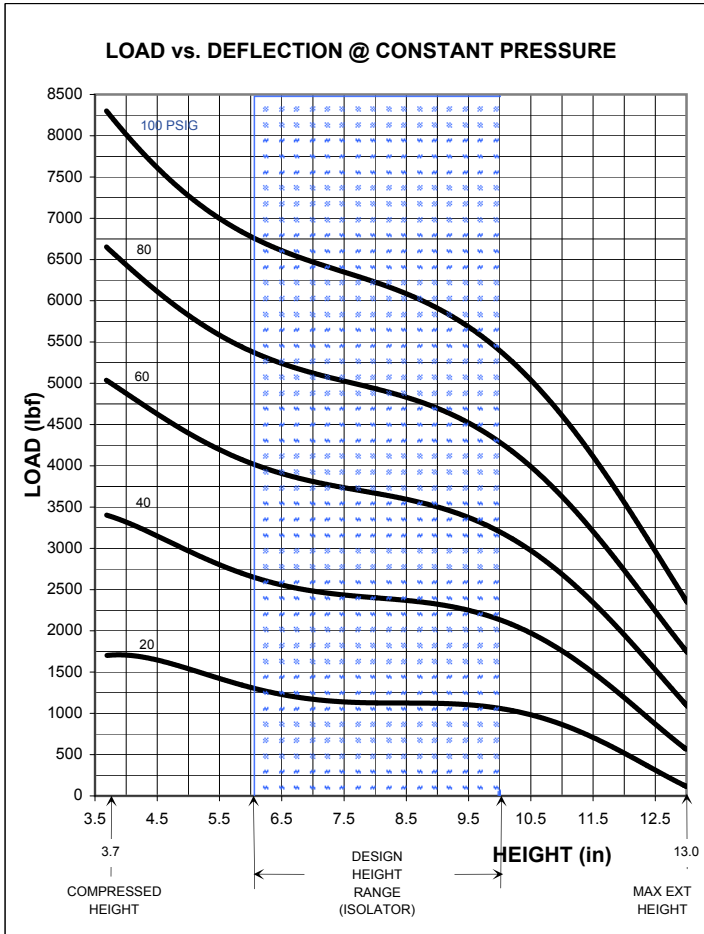

****NOTE: MAXIMUM INFLATION PRESSURE IS 100 PSIG. MAXIMUM JOUNCE PRESSURE IS 200 PSIG. IF YOUR APPLICATION WILL EXCEED THESE LIMITS, CONSULT A GOODYEAR ENGINEERED PRODUCTS AIR SPRINGS REPRESENTATIVE FOR APPLICATION ASSISTANCE.**

CONSTANT PRESSURE CHARACTERISTICS

Assembly Height (in)	Meniscus Height "M" Dim. @ 100 PSIG (in)	Volume @ 100 PSIG (in ³)	Nominal Force (lb)				
			@ 20 PSIG	@ 40 PSIG	@ 60 PSIG	@ 80 PSIG	@ 100 PSIG
13.0	1.9	699	60	460	1100	1800	2300
11.0	1.9	696	850	1700	2700	3600	4600
10.0	1.9	635	1100	2200	3200	4300	5500
9.0	1.6	570	1150	2400	3600	4900	5800
8.0	1.4	501	1200	2600	3900	5300	6600
7.0	0.6	433	1200	2500	3800	5200	6500
6.0	0.1	369	1400	2700	4000	5400	6700
5.0	0.1	304	1700	3100	4600	6100	7600
4.0	0.0	250	1800	3400	5000	6600	8200
3.7	0.0	225	2100	3600	5100	6700	8300

DYNAMIC CHARACTERISTICS

Design Height (in)	Load (lb)	Pressure (PSIG)	Spring Rate (lb/in)	Natural Frequency	
				cpm	Hz
10.0	2000	37	630	105	1.75
	3000	56	910	103	1.72
	5000	93	1425	100	1.67
8.0	2000	31	500	94	1.57
	3000	46	690	91	1.52
	5000	75	1120	90	1.50
6.0	6000	89	1320	89	1.48
	2000	29	1000	133	2.22
	3000	45	1315	124	2.07
6.0	5000	74	1855	115	1.92
	6000	89	2180	113	1.88

The GOODYEAR (and Winged Foot Design) trademark is used by Veyance Technologies, Inc. under license from The Goodyear Tire & Rubber Company. Goodyear Engineered Products are manufactured and sourced exclusively by Veyance Technologies, Inc. or its affiliates. The following trademarks are licensed to Veyance Technologies, Inc. by The Goodyear Tire & Rubber Company, including Compass, Eagle Pd, Flexten, Gatorback and GY Metric. ©2008 Veyance Technologies, Inc. All Rights Reserved.



1R11-039

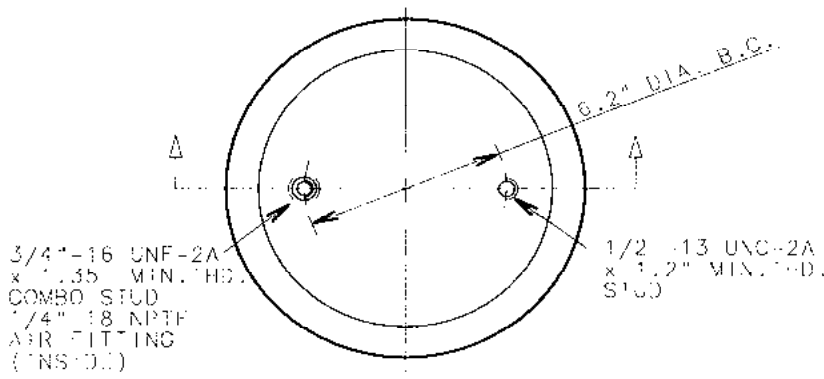

TOP VIEW

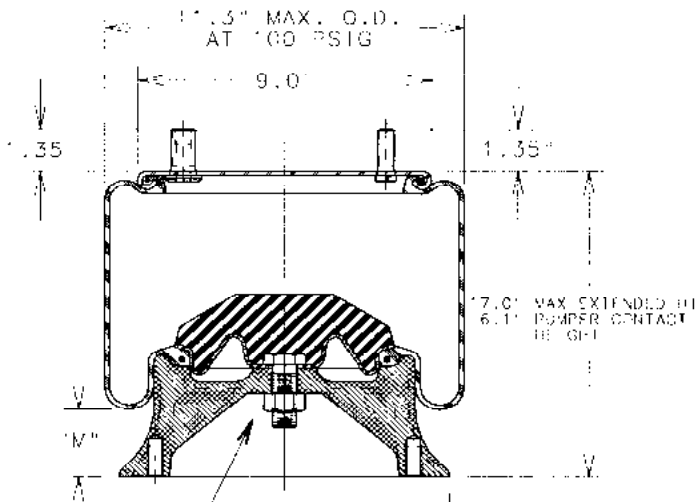

SIDE VIEW

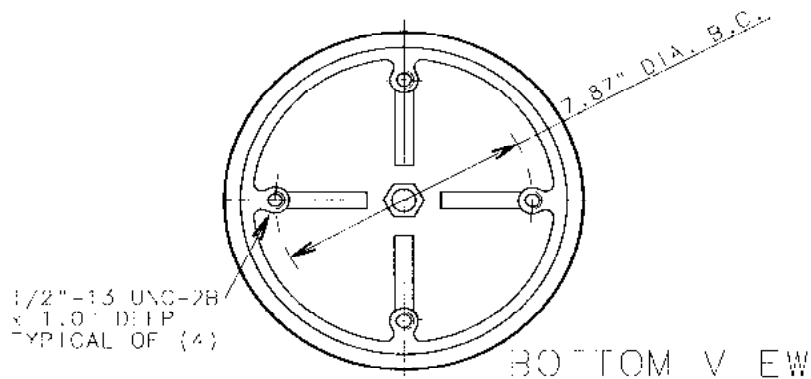

BOTTOM VIEW

ASSEMBLY NUMBER	ELASTOMER	AIR FITTING	BUMPER INCLUDED
1R11-039	NAT. RUBBER	1/4"-18 NPTF COMBO STUD	YES

SPRING FEATURES:

- LOAD RANGE (ISOLATOR).....1300-7000 lb
- DESIGN HEIGHT RANGE (ISOLATOR).....8.0-12.0 in
- USABLE STROKE (ACTUATOR).....10.9 in
- ASSEMBLY WEIGHT.....17.0 lb
- ALUMINUM PISTON

OTHER OPTIONS:

- METRIC ATTACHMENTS
- UPPER BEAD PLATE:
 - ALTERNATE BEAD LENGTHS AND SPACINGS
 - ALTERNATE AIR FITTING SIZES AND LOCATIONS
 - NO BUMPER OR ALTERNATE BUMPER
- PISTON:
 - ALTERNATE HEIGHTS
 - STEEL PISTON WITH GREATER EFFECTIVE AREA

RECOMMENDED MAX. TORQUE VALUES

3/4"-16 UNF COMBO STUD	1/2"-13 UNC TOP STUD	1/2"-13 UNC BINDING TAP EXP. OF (4)	1/4"-18 UNC AIR FITTING
600 in-lb 50 ft-lb	500 in-lb 25 ft-lb	600 in-lb 50 ft-lb	240 in-lb 20 ft-lb
3/4"-10 UNC HEX LOCKNUT			
900 in-lb 75 ft-lb			

NOTE: SEE GUIDELINES FOR PROPER APPLICATION OF THIS PRODUCT

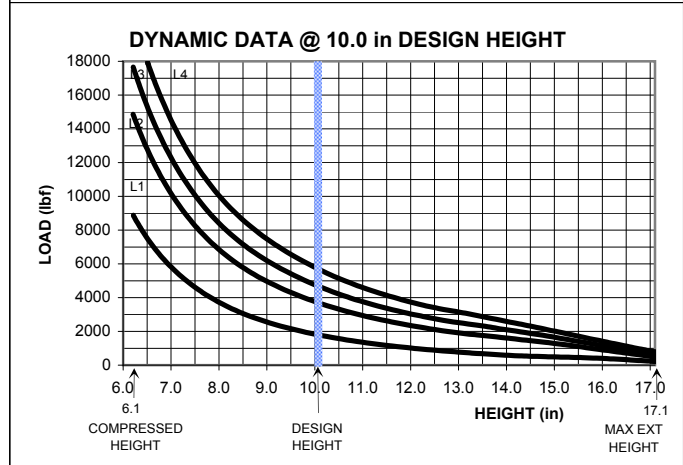
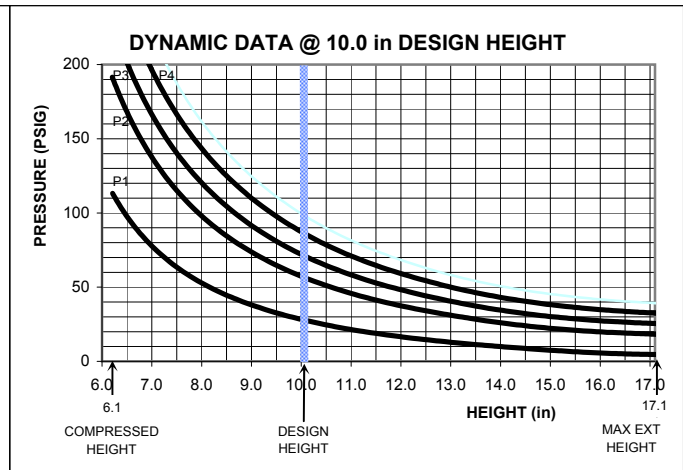
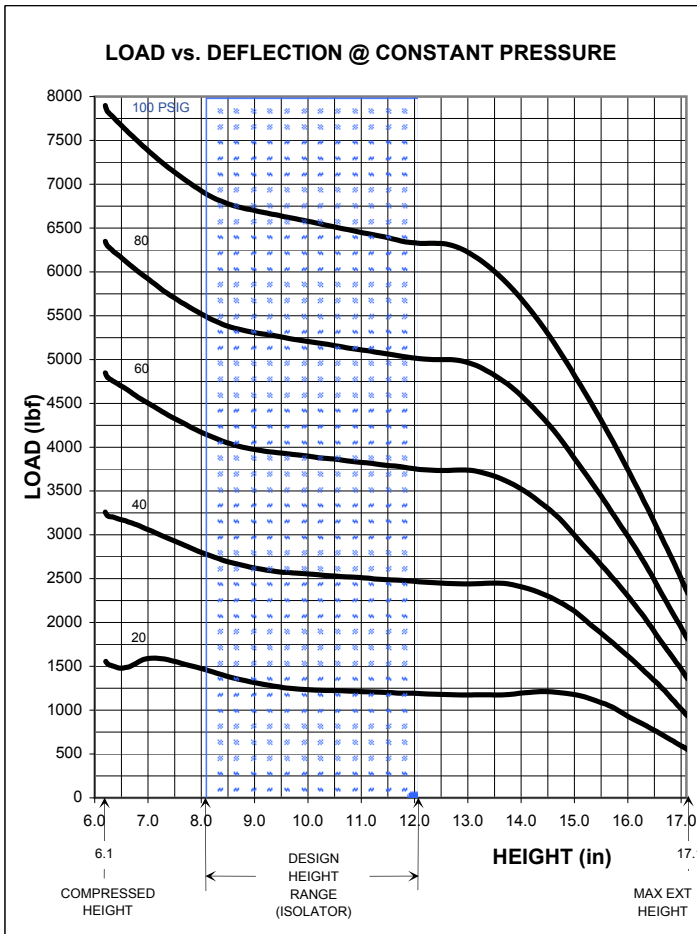

****NOTE: MAXIMUM INFLATION PRESSURE IS 100 PSIG. MAXIMUM JOUNCE PRESSURE IS 200 PSIG. IF YOUR APPLICATION WILL EXCEED THESE LIMITS, CONSULT A GOODYEAR ENGINEERED PRODUCTS AIR SPRINGS REPRESENTATIVE FOR APPLICATION ASSISTANCE.**

CONSTANT PRESSURE CHARACTERISTICS

Assembly Height (in)	Meniscus Height "M" Dim. @ 100 PSIG (in)	Volume @ 100 PSIG (in ³)	Nominal Force (lb)				
			@ 20 PSIG	@ 40 PSIG	@ 60 PSIG	@ 80 PSIG	@ 100 PSIG
17.1	4.8	936	560	900	1350	1800	2300
16.0	4.6	887	950	1600	2300	3000	3700
15.0	4.3	830	1200	2100	3000	3800	4800
14.0	4.1	762	1250	2400	3500	4600	5700
13.0	3.7	686	1250	2500	3800	5100	6300
12.0	3.3	609	1300	2500	3800	5100	6500
10.0	2.1	463	1300	2600	4000	5300	6700
8.0	1.1	326	1500	2800	4200	5600	7000
7.0	0.6	263	1700	3100	4600	6000	7500
6.1	0.4	212	1500	3300	4900	6300	7900

DYNAMIC CHARACTERISTICS

Design Height (in)	Load (lb)	Pressure (PSIG)	Spring Rate (lb/in)	Natural Frequency	
				cpm	Hz
12.0	2000	31	455	90	1.50
	4000	62	765	82	1.37
	5000	78	910	80	1.33
10.0	2000	30	605	103	1.72
	4000	60	1025	95	1.58
	5000	75	1245	94	1.57
8.0	2000	27	920	127	2.12
	4000	57	1535	116	1.93
	5000	72	1865	114	1.90
	6000	85	2110	112	1.87
	7000	99	2435	111	1.85

The GOODYEAR (and Winged Foot Design) trademark is used by Veyance Technologies, Inc. under license from The Goodyear Tire & Rubber Company. Goodyear Engineered Products are manufactured and sourced exclusively by Veyance Technologies, Inc. or its affiliates. The following trademarks are licensed to Veyance Technologies, Inc. by The Goodyear Tire & Rubber Company, including Compass, Eagle Pd, Flexten, Gatorback and GY Metric. ©2008 Veyance Technologies, Inc. All Rights Reserved.



1R12-092

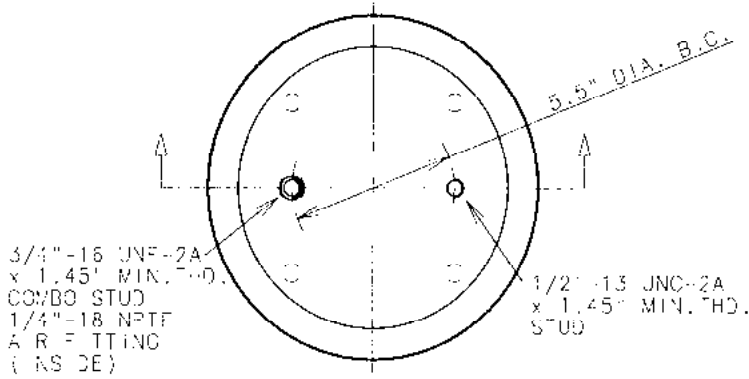

TOP VIEW

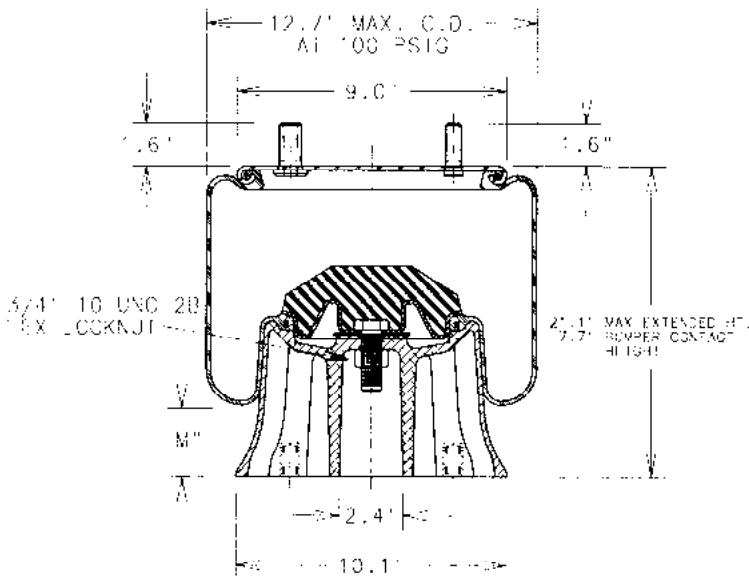

SIDE VIEW

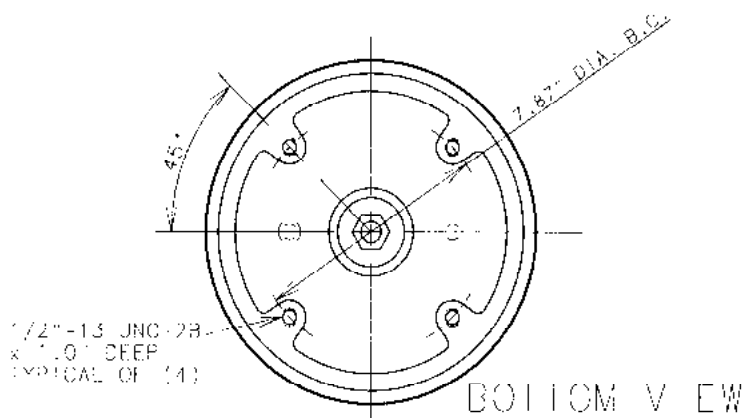

BOTTOM VIEW

ASSEMBLY NUMBER	ELASTOMER	AIR FITTING	BUMPER INCLUDED
1R12-092	NAI, RUBBER	1/4"-18 NPTF COMBO STUD	YES

SPRING FEATURES:

- LOAD RANGE (ISOLATOR).....1350-7600 lb
- DESIGN HEIGHT RANGE (ISOLATOR)....10.5-16.5 in
- USABLE STROKE (ACTUATOR).....13.4 in
- ASSEMBLY WEIGHT.....18.3 lb
- COMPOSED PISTON

OTHER OPTIONS:

- METRIC ATTACHMENTS
- UPPER READ PLATE:
 - ALTERNATE BOLT LENGTHS AND SPACINGS
 - ALTERNATE AIR FITTING SIZES AND LOCATIONS
 - NO BUMPER OR ALTERNATE BUMPER
- PISTON:
 - ALTERNATE HEIGHTS
 - ALUMINUM PISTON
 - STEEL PISTON WITH GREATER EFFECTIVE AREA

RECOMMENDED MAX. TORQUE VALUES

3/4"-16 UNF COMBO STUD	1/2"-13 UNC TOP STUD	1/2"-13 UNC BOND TAP TYP. OF (4)	1/4"-18 UNC AIR FITTING
600 in-lb 75 ft-lb	300 in-lb 75 ft-lb	300 in-lb 25 ft-lb	240 in-lb 20 ft-lb
3/4"-18 UNC HEX LOCKNUT			
800 in-lb 75 ft-lb			

NOTE: SEE GUIDELINES FOR PROPER APPLICATION OF THIS PRODUCT

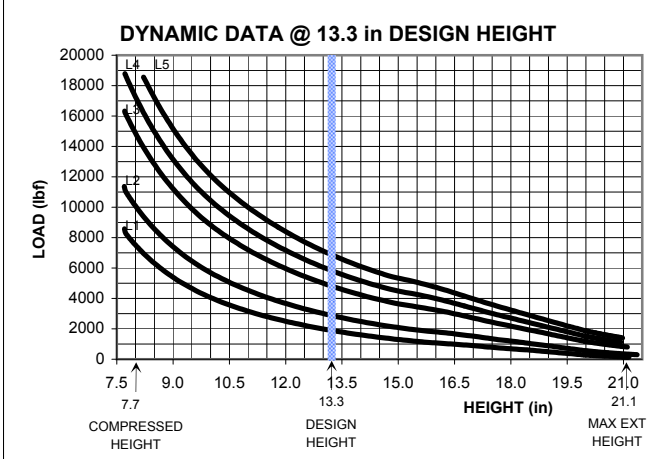
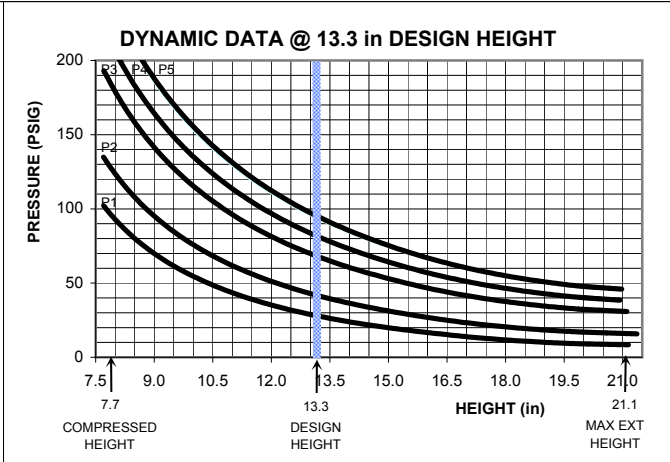
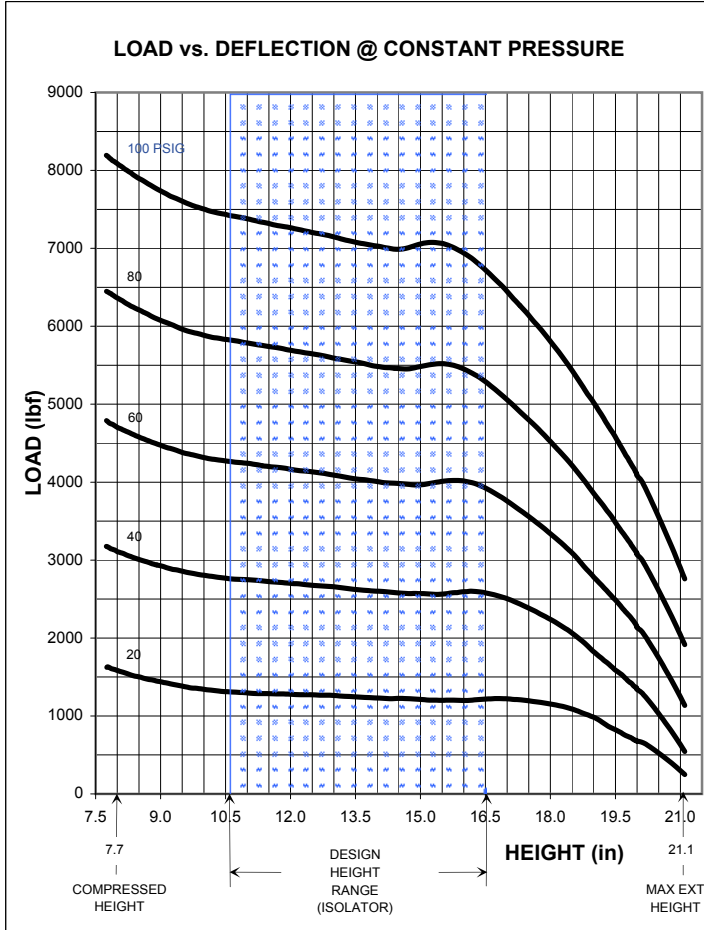

****NOTE: MAXIMUM INFLATION PRESSURE IS 100 PSIG. MAXIMUM JOUNCE PRESSURE IS 200 PSIG. IF YOUR APPLICATION WILL EXCEED THESE LIMITS, CONSULT A GOODYEAR ENGINEERED PRODUCTS AIR SPRINGS REPRESENTATIVE FOR APPLICATION ASSISTANCE.**

CONSTANT PRESSURE CHARACTERISTICS

Assembly Height (in)	Meniscus Height "M" Dim. @ 100 PSIG (in)	Volume @ 100 PSIG (in ³)	Nominal Force (lb)				
			@ 20 PSIG	@ 40 PSIG	@ 60 PSIG	@ 80 PSIG	@ 100 PSIG
21.1	5.9	1330	320	620	1200	1700	2700
20.0	5.7	1259	680	1350	2100	3000	4100
18.0	5.5	1124	1200	2200	3400	4600	5900
16.5	5.1	1010	1350	2700	3900	5300	6800
15.0	4.4	891	1300	2700	4200	5700	7300
13.3	3.4	762	1350	2800	4200	5700	7300
12.0	2.7	634	1400	2800	4300	5800	7400
10.5	1.8	563	1400	2900	4400	5900	7600
9.0	1.1	463	1500	3000	4500	6100	4800
7.7	0.5	379	1600	3200	4700	6400	8100

DYNAMIC CHARACTERISTICS

Design Height (in)	Load (lb)	Pressure (PSIG)	Spring Rate (lb/in)	Natural Frequency	
				cpm	Hz
16.5	2000	29	395	84	1.40
	3000	43	580	83	1.38
	5000	71	900	80	1.33
	6000	86	1065	79	1.32
13.3	7000	100	1210	78	1.30
	2000	29	425	86	1.43
	3000	43	585	83	1.38
	5000	69	830	77	1.28
10.5	6000	83	960	75	1.25
	7000	95	1090	74	1.23
	2000	27	625	105	1.75
	3000	41	795	97	1.62
10.5	5000	68	1160	90	1.50
	6000	80	1315	88	1.47
	7000	94	1485	86	1.43

The GOODYEAR (and Winged Foot Design) trademark is used by Veyance Technologies, Inc. under license from The Goodyear Tire & Rubber Company. Goodyear Engineered Products are manufactured and sourced exclusively by Veyance Technologies, Inc. or its affiliates. The following trademarks are licensed to Veyance Technologies, Inc. by The Goodyear Tire & Rubber Company, including Compass, Eagle Pd, Flexten, Gatorback and GY Metric. ©2008 Veyance Technologies, Inc. All Rights Reserved.



1R12-095

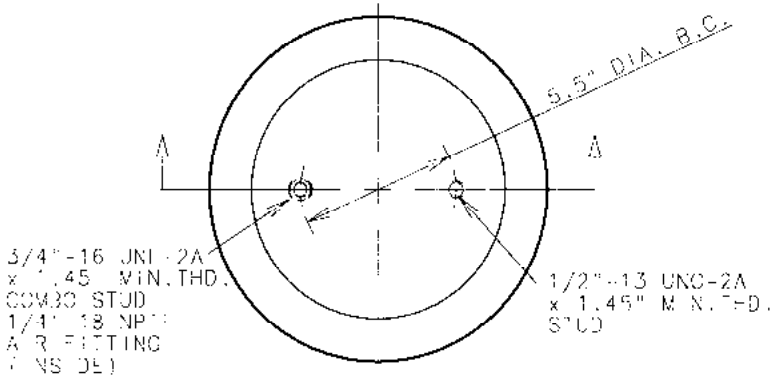

TOP VIEW

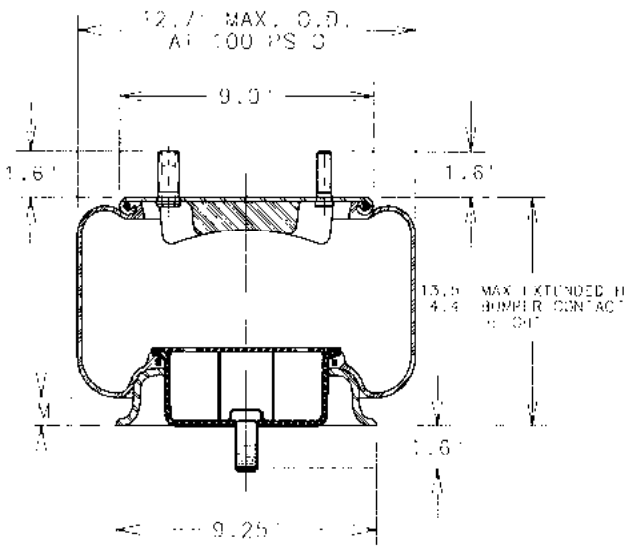

SIDE VIEW

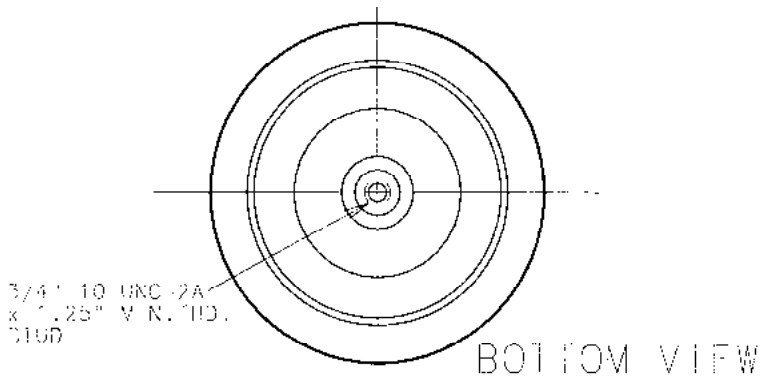

BOTTOM VIEW

ASSEMBLY NUMBER	Elastomer	AIR FITTING	BUMPER INCLUDED
1R12-095	NAT. RUBBER	1/4" 18 NPT COMBO STUD	YES

SPRING FEATURES:

- LOAD RANGE (ISOLATOR).....1350-7300 Lb
- DESIGN HEIGHT RANGE (ISOLATOR).....7.0-9.0"
- USABLE STROKE (ACTUATOR).....9.1"
- ASSEMBLY WEIGHT.....13.9 Lb
- STEEL PISTON

OTHER OPTIONS:

- METRIC ATTACHMENTS
- UPPER BLAD PLATE:
- ALTERNATE BOLT LENGTHS AND SPACINGS
- ALTERNATE AIR FITTING SIZES AND LOCATIONS
- NO BUMPER OR ALTERNATE BUMPER

RECOMMENDED MAX. TORQUE VALUES

3/4"-16 UNF COMBO STUD	1/2"-13 UNF TOP STUD	3/4"-10 UNF BOTTOM STUD	1/4" 18 UNF AIR FITTING
600 in-lb 50 ft-lb	300 in-lb 25 ft-lb	600 in-lb 50 ft-lb	240 in-lb 20 ft-lb

NOTE: SEE GUIDELINES FOR PROPER APPLICATION OF THIS PRODUCT

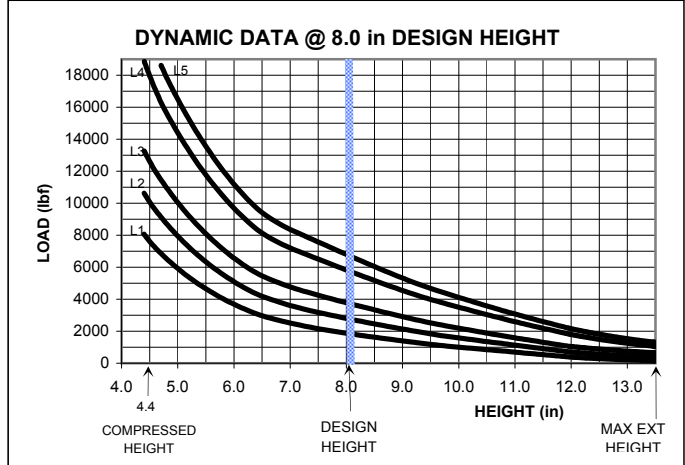
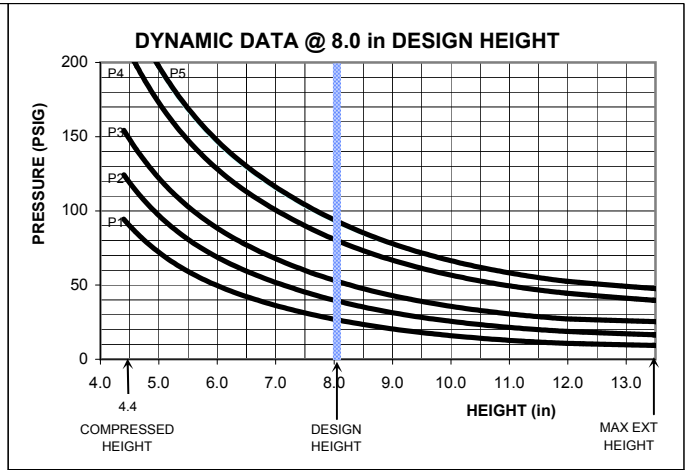
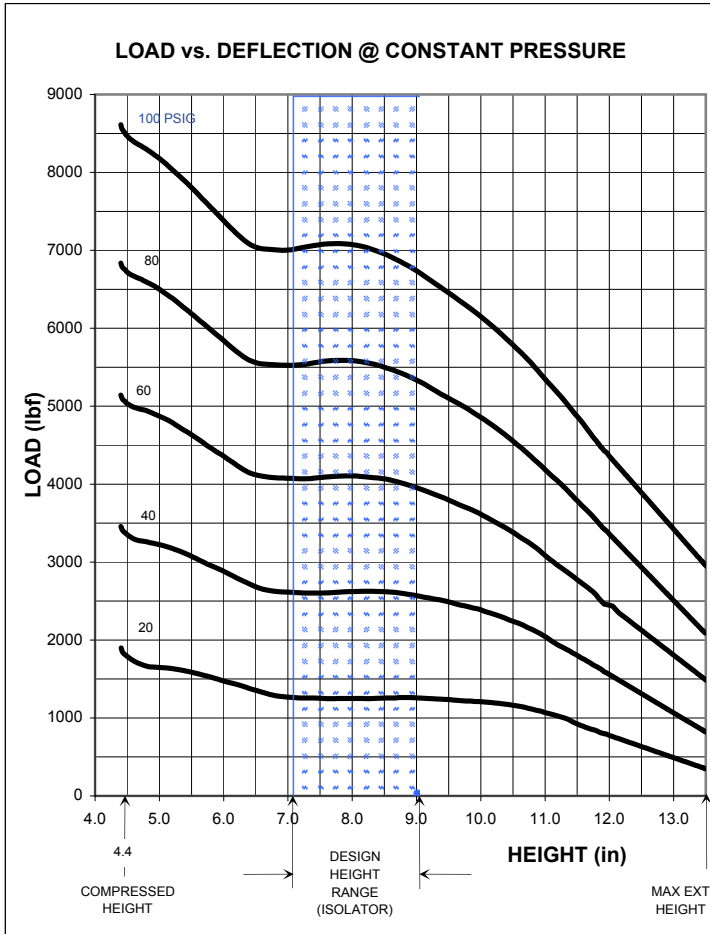

****NOTE: MAXIMUM INFLATION PRESSURE IS 100 PSIG. MAXIMUM JOUNCE PRESSURE IS 200 PSIG. IF YOUR APPLICATION WILL EXCEED THESE LIMITS, CONSULT A GOODYEAR ENGINEERED PRODUCTS AIR SPRINGS REPRESENTATIVE FOR APPLICATION ASSISTANCE.**

CONSTANT PRESSURE CHARACTERISTICS

Assembly Height (in)	Meniscus Height "M" Dim. @ 100 PSIG (in)	Volume @ 100 PSIG (in ³)	Nominal Force (lb)				
			@ 20 PSIG	@ 40 PSIG	@ 60 PSIG	@ 80 PSIG	@ 100 PSIG
13.5	2.1	875	240	400	1000	1700	2400
12.0	2.1	777	750	1500	2400	3300	4300
11.0	2.1	713	1080	2000	3100	4200	5400
10.0	1.8	646	1250	2400	3600	4900	6200
9.0	1.5	574	1350	2700	4000	5400	6800
8.0	1.1	501	1350	2700	4300	5800	7300
7.0	0.4	431	1350	2700	4200	5700	7300
6.0	0.3	364	1500	2900	4400	5900	7500
5.0	0.1	296	1700	3300	4900	6600	8200
4.4	0.0	256	1800	3300	5100	6800	8600

DYNAMIC CHARACTERISTICS

Design Height (in)	Load (lb)	Pressure (PSIG)	Spring Rate (lb/in)	Natural Frequency	
				cpm	Hz
9.0	2000	29	605	103	1.72
	3000	43	845	100	1.67
	4000	58	1090	98	1.63
	6000	87	1515	94	1.57
	7000	100	1730	93	1.55
8.0	2000	28	575	100	1.67
	3000	42	755	94	1.57
	4000	55	975	93	1.55
	6000	83	1430	91	1.52
	7000	96	1615	90	1.50
7.0	2000	29	680	109	1.82
	3000	43	865	101	1.68
	4000	57	1045	96	1.60
	6000	84	1295	88	1.47
	7000	98	1500	87	1.45

The GOODYEAR (and Winged Foot Design) trademark is used by Veyance Technologies, Inc. under license from The Goodyear Tire & Rubber Company. Goodyear Engineered Products are manufactured and sourced exclusively by Veyance Technologies, Inc. or its affiliates. The following trademarks are licensed to Veyance Technologies, Inc. by The Goodyear Tire & Rubber Company, including Compass, Eagle Pd, Flexten, Gatorback and GY Metric. ©2008 Veyance Technologies, Inc. All Rights Reserved.



1R12-103

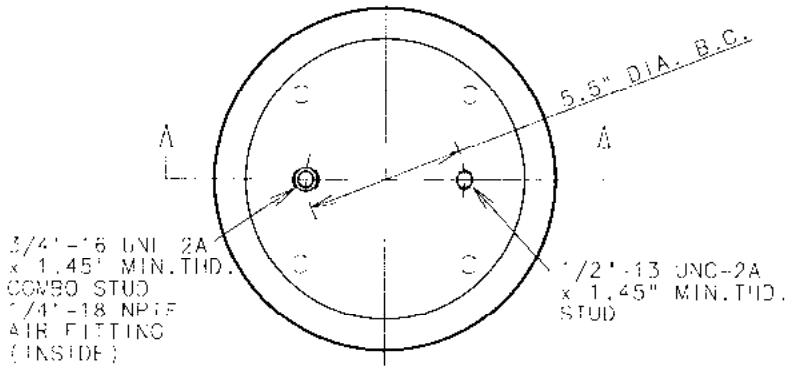

TOP VIEW

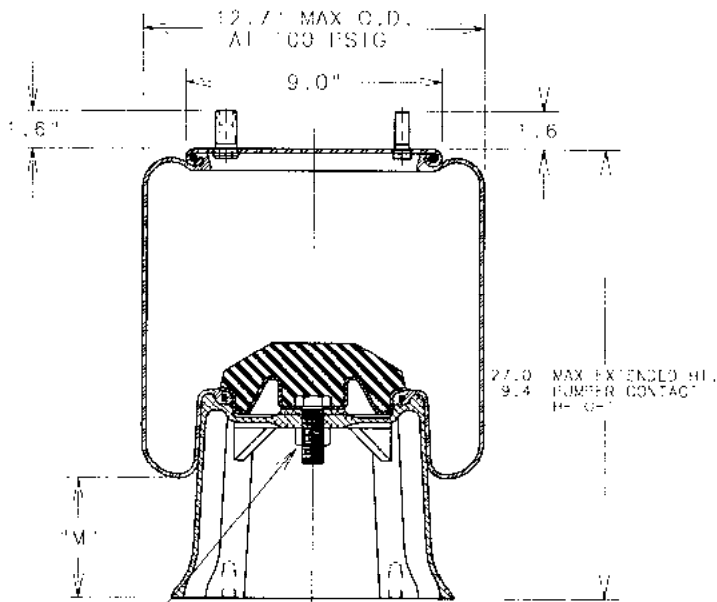

SIDE VIEW

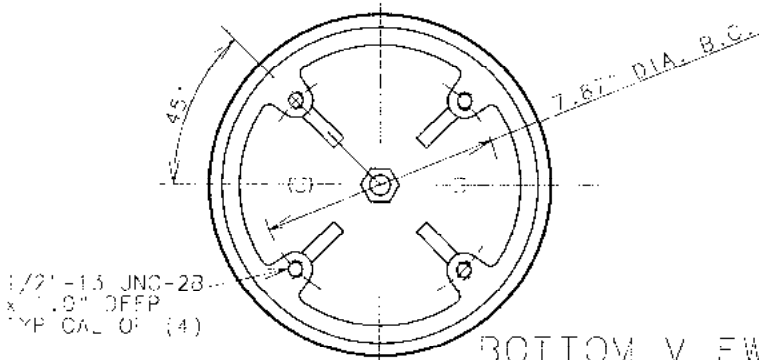

BOTTOM VIEW

ASSEMBLY NUMBER	ELASTOMER	AIR FITTING	BUMPER INCLUDED
1R12-103	NAT. RUBBER	1/4"-18 NPTF COMBO STUD	YES

SPRING FEATURES:

- LOAD RANGE (ISOLATOR).....300-7500 lb
- DESIGN HEIGHT RANGE (ISOLATOR).....15.0-20.0 in
- USEABLE STROKE (ACTUATOR).....17.6 in
- ASSEMBLY WEIGHT.....22.3 lb
- ALUM. N.W. PISTON

OTHER OPTIONS:

- VEHR C ATTACHMENTS
- UPPER BLAD PLATE:
 - ALTERNATE BOLT LENGTHS AND SPACINGS
 - ALTERNATE AIR FITTING SIZES AND LOCATIONS
 - NO BUMPER OR ALTERNATE BUMPER
- PISTON:
 - ALTERNATE HEIGHTS
 - STEEL PISTON WITH GREATER EFFECTIVE AREA

RECOMMENDED MAX. TORQUE VALUES

3/4"-10 UNC COMBO STUD	1/2"-13 UNC TOP STUD	1/2"-13 UNC BLIND TAP END OF (4)	1/4"-18 UNC AIR FITTING
600 in-lb 50 ft-lb	500 in-lb 25 ft-lb	600 in-lb 50 ft-lb	240 in-lb 20 ft-lb
3/4"-10 UNC HEX LOCKNUT			
900 in-lb 75 ft-lb			

NOTE: SEE GUIDELINES FOR PROPER APPLICATION OF THIS PRODUCT.

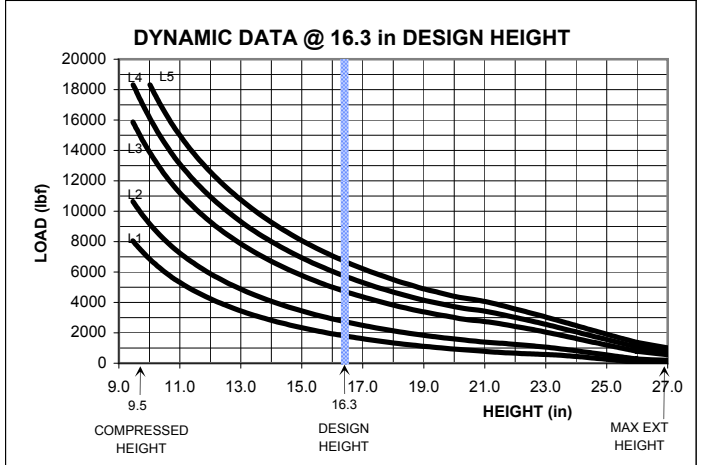
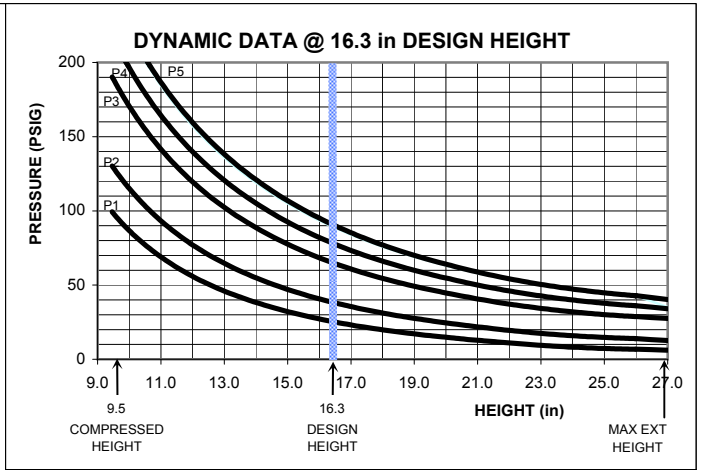
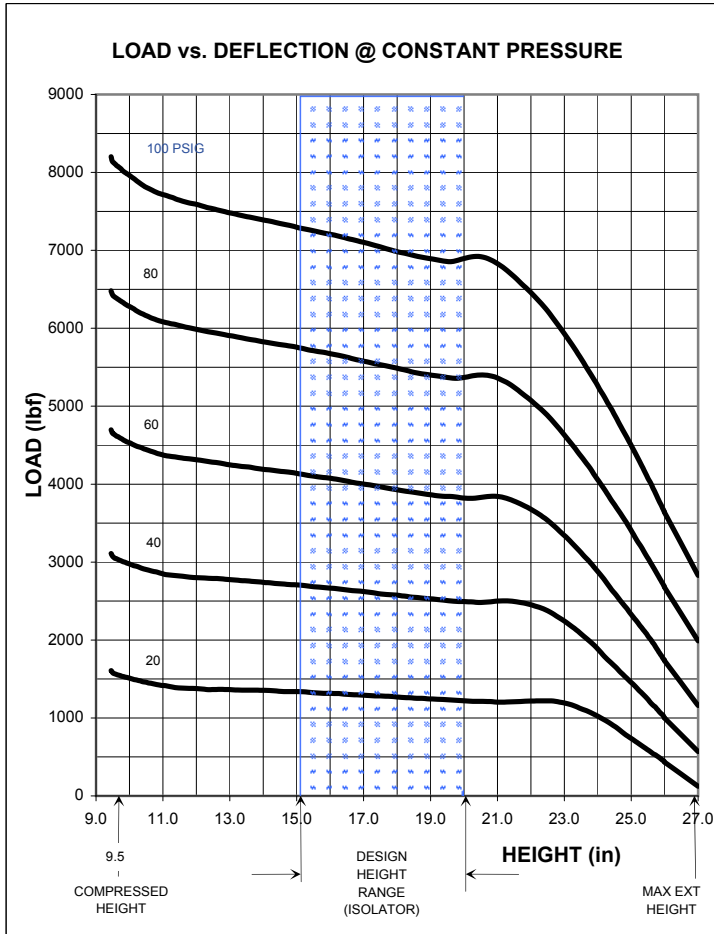

****NOTE: MAXIMUM INFLATION PRESSURE IS 100 PSIG. MAXIMUM JOUNCE PRESSURE IS 200 PSIG. IF YOUR APPLICATION WILL EXCEED THESE LIMITS, CONSULT A GOODYEAR ENGINEERED PRODUCTS AIR SPRINGS REPRESENTATIVE FOR APPLICATION ASSISTANCE.**

CONSTANT PRESSURE CHARACTERISTICS

Assembly Height (in)	Meniscus Height "M" Dim. @ 100 PSIG (in)	Volume @ 100 PSIG (in ³)	Nominal Force (lb)				
			@ 20 PSIG	@ 40 PSIG	@ 60 PSIG	@ 80 PSIG	@ 100 PSIG
			27.0	7.6	1680	100	400
24.0	7.3	1506	1050	1900	2900	4100	5300
22.0	7.1	1358	1300	2500	3800	5200	6500
20.0	6.1	1200	1300	2500	3800	5400	6900
18.0	5.0	1047	1350	2600	3900	5500	7000
16.3	4.1	922	1450	2600	3900	5500	7200
15.0	3.3	800	1450	2700	4100	5700	7300
13.0	2.9	689	1450	2800	4200	5900	7500
11.0	1.0	557	1500	2900	4400	6100	7700
9.5	0.4	455	1600	3100	4700	6500	8200

DYNAMIC CHARACTERISTICS

Design Height (in)	Load (lb)	Pressure (PSIG)	Spring Rate (lb/in)	Natural Frequency	
				cpm	Hz
20.0	2000	30	285	70	1.17
	3000	44	315	60	1.00
	5000	71	430	55	0.92
	6000	83	465	54	0.90
	7000	97	555	53	0.88
16.3	2000	27	355	79	1.32
	3000	41	460	74	1.23
	5000	68	670	69	1.15
	6000	82	780	68	1.13
	7000	94	895	67	1.12
15.0	2000	27	370	81	1.35
	3000	40	505	77	1.28
	5000	68	755	72	1.20
	6000	80	865	71	1.18
	7000	93	980	70	1.17

The GOODYEAR (and Winged Foot Design) trademark is used by Veyance Technologies, Inc. under license from The Goodyear Tire & Rubber Company. Goodyear Engineered Products are manufactured and sourced exclusively by Veyance Technologies, Inc. or its affiliates. The following trademarks are licensed to Veyance Technologies, Inc. by The Goodyear Tire & Rubber Company, including Compass, Eagle Pd, Flexten, Gatorback and GY Metric. ©2008 Veyance Technologies, Inc. All Rights Reserved.



1R12-132

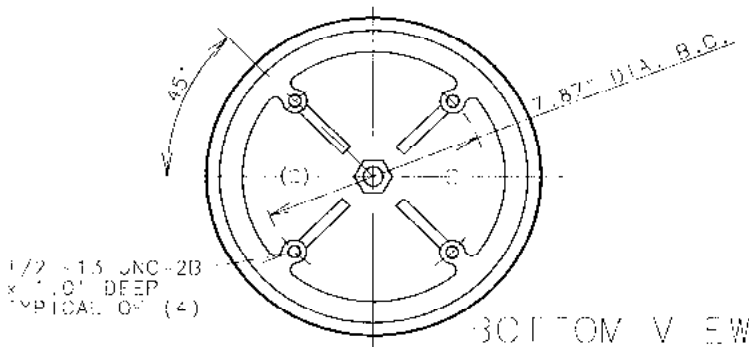
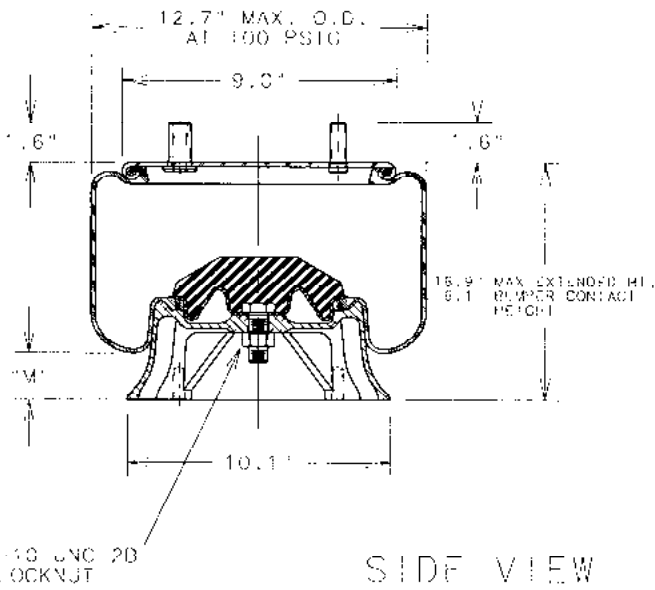
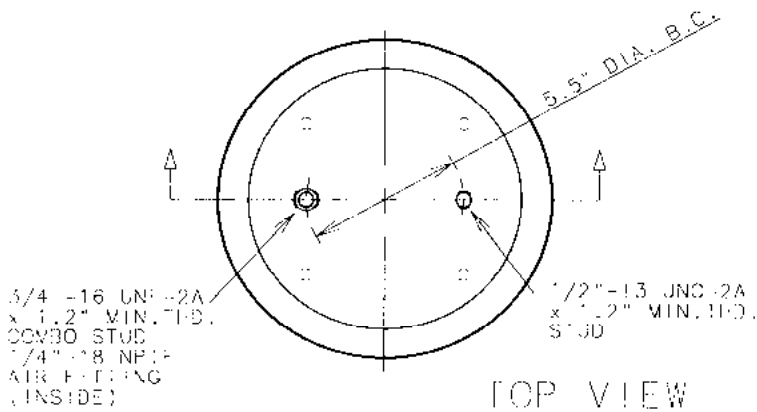

ASSEMBLY NUMBER	ELASTOMER	AIR FITTING	BUMPER INCLUDED
1R12-132	NAT. RUBBER	3/4"-18 NPT COMBO STUD	YES

SPRING FEATURES:

- LOAD RANGE (SOLATOR).....1400-7600 lb
- DESIGN HEIGHT RANGE (SOLATOR).....5.0-10.0 in
- USEABLE STROKE (ACTUATOR).....10.8 in
- ASSEMBLY WEIGHT.....16.9 lb
- ALUM NUM PISTON

OTHER OPTIONS:

- METRIC ATTACHMENTS
- UPPER BEAD PLATE:
 - ALTERNATE BOLT LENGTHS AND SPACINGS
 - ALTERNATE AIR FITTING SIZES AND LOCAL GAS
 - NO BUMPER OR ALTERNATE BUMPER
- PISTON:
 - ALTERNATE HEIGHTS
 - STEEL PISTON WITH GREATER EFFECTIVE AREA

RECOMMENDED MAX. TORQUE VALUES

3/4"-16 UNI COMBO STUD	1/2"-13 UNC 10° STUD	1/2"-13 UNC BLIND TAP TYP. OF (4)	3/4"-18 UNC AIR FITTING
500 in-lb 50 ft-lb	300 in-lb 25 ft-lb	800 in-lb 80 ft-lb	240 in-lb 20 ft-lb
3/4"-10 UNC PLX LOCKNUT			
900 in-lb 75 ft-lb			

NOTE: SEE GUIDELINES FOR PROPER APPLICATION OF THIS PRODUCT

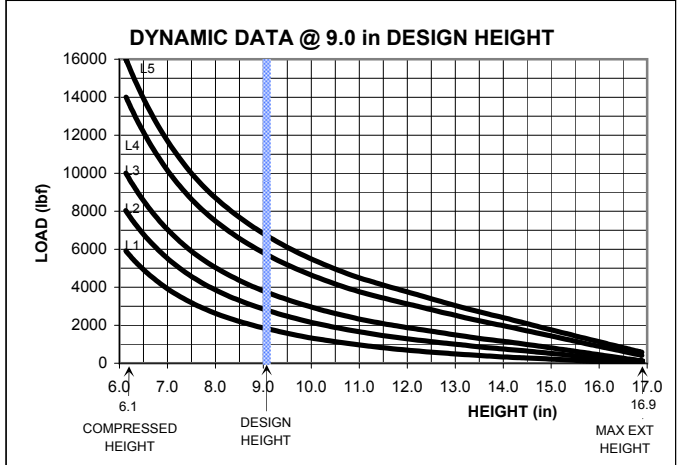
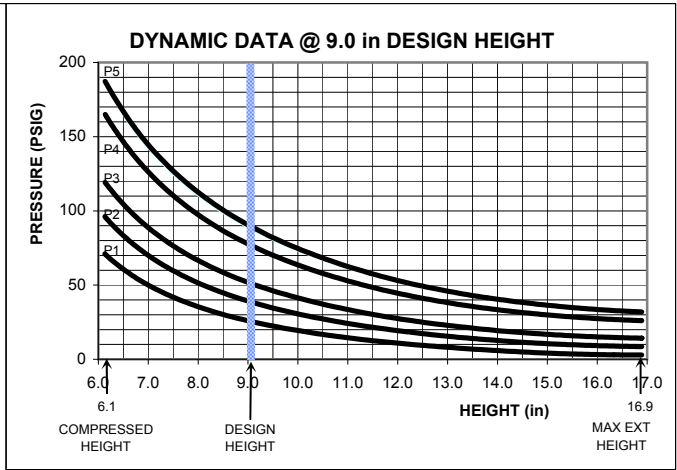
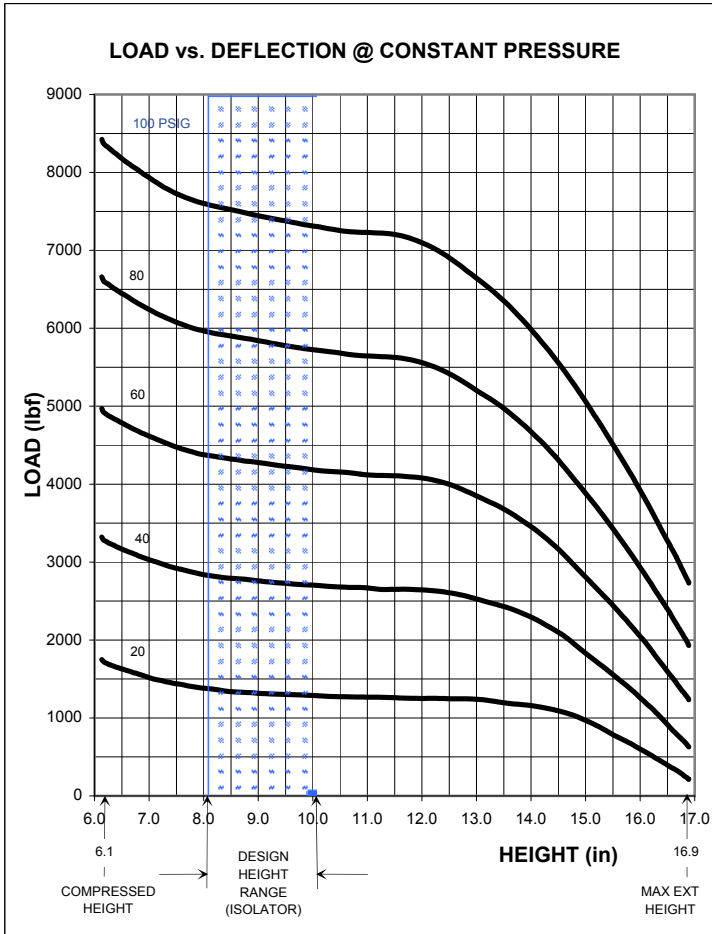

****NOTE: MAXIMUM INFLATION PRESSURE IS 100 PSIG. MAXIMUM JOUNCE PRESSURE IS 200 PSIG. IF YOUR APPLICATION WILL EXCEED THESE LIMITS, CONSULT A GOODYEAR ENGINEERED PRODUCTS AIR SPRINGS REPRESENTATIVE FOR APPLICATION ASSISTANCE.**

CONSTANT PRESSURE CHARACTERISTICS

Assembly Height (in)	Meniscus Height "M" Dim. @ 100 PSIG (in)	Volume @ 100 PSIG (in ³)	Nominal Force (lb)				
			@ 20 PSIG	@ 40 PSIG	@ 60 PSIG	@ 80 PSIG	@ 100 PSIG
16.9	4.1	1089	220	620	1200	1900	2700
15.0	4.1	983	950	1800	2800	3900	5100
13.0	3.7	834	1300	2600	3800	5300	6600
12.0	3.3	753	1350	2800	4000	5500	7100
11.0	2.8	672	1350	2800	4100	5600	7200
10.0	2.3	595	1400	2800	4200	5700	7400
9.0	1.7	521	1400	2900	4300	5800	7500
8.0	1.1	448	1450	2900	4400	6000	7600
7.0	0.7	378	1500	3100	4700	6300	7900
6.1	0.3	320	1700	3300	5000	6700	8400

DYNAMIC CHARACTERISTICS

Design Height (in)	Load (lb)	Pressure (PSIG)	Spring Rate (lb/in)	Natural Frequency	
				cpm	Hz
10.0	2000	28	550	98	1.63
	3000	42	700	91	1.52
	4000	55	900	89	1.48
	6000	81	1190	83	1.38
9.0	7000	94	1335	82	1.37
	2000	27	655	107	1.78
	3000	41	840	99	1.65
	4000	54	1035	95	1.58
8.0	6000	80	1400	91	1.52
	7000	93	1595	89	1.48
	2000	27	780	117	1.95
	3000	40	1025	109	1.82
8.0	4000	54	1260	105	1.75
	6000	79	1660	99	1.65
	7000	92	1905	98	1.63

The GOODYEAR (and Winged Foot Design) trademark is used by Veyance Technologies, Inc. under license from The Goodyear Tire & Rubber Company. Goodyear Engineered Products are manufactured and sourced exclusively by Veyance Technologies, Inc. or its affiliates. The following trademarks are licensed to Veyance Technologies, Inc. by The Goodyear Tire & Rubber Company, including Compass, Eagle Pd, Flexten, Gatorback and GY Metric. ©2008 Veyance Technologies, Inc. All Rights Reserved.



1R12-256

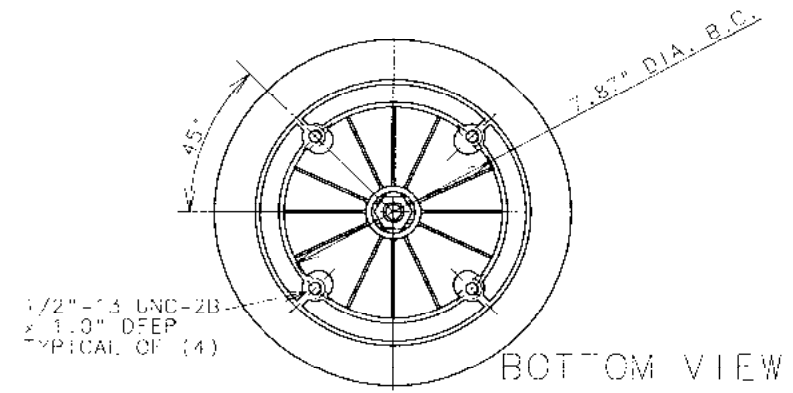
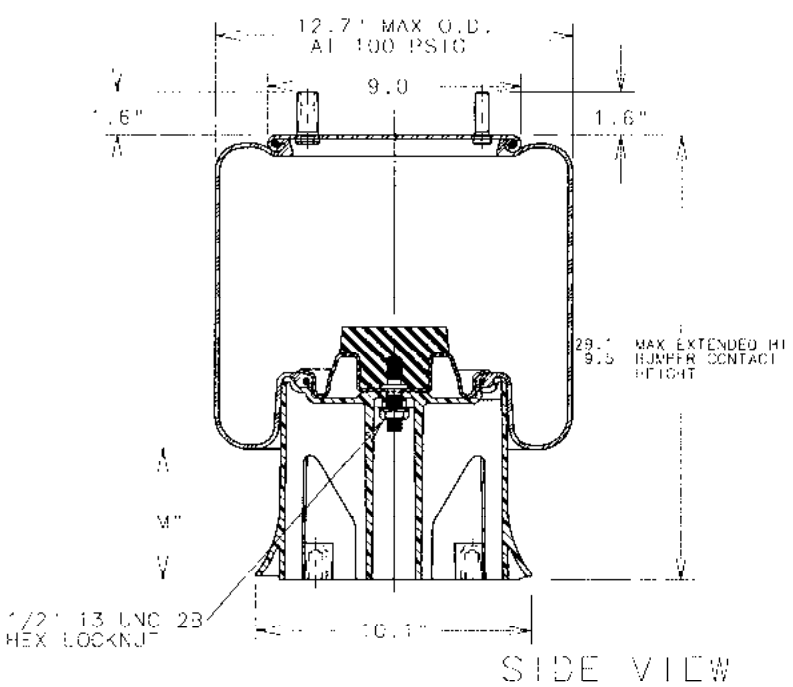
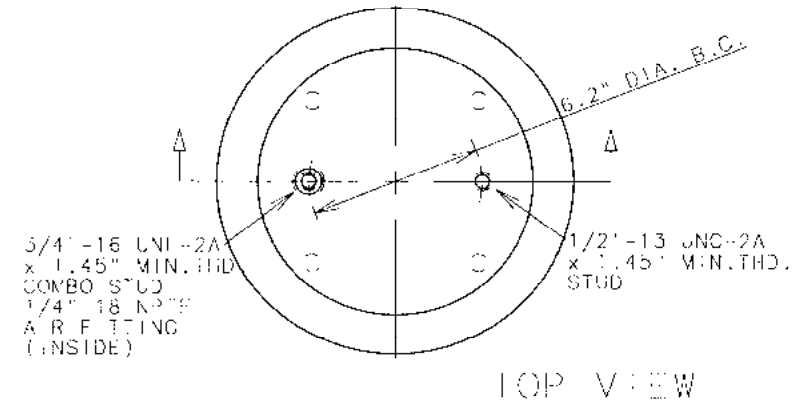

ASSEMBLY NUMBER	ELASTOMER	AIR FITTING	BUMPER INCLUDED
1R12-256	NAT. RUBBER	1/4"-18 NPTF COMBO STUD	YES

SPRING FEATURES:

- LOAD RANGE (ACTUATOR).....1350-7300 lb
- DESIGN HEIGHT RANGE (ISOLATOR).....16.0-20.0 in
- USEABLE STROKE (ACTUATOR).....19.6 in
- ASSEMBLY WEIGHT.....23.0 lb
- COMPOSITE PISTON

OTHER OPTIONS:

- METRIC ATTACHMENTS
- UPPER BEAD PLATE:
 - ALTERNATE BEAD LENGTHS AND SPACINGS
 - ALTERNATE AIR FITTING SIZES AND LOCATIONS
 - NO BUMPER OR ALTERNATE BUMPER
- PISTON:
 - ALTERNATE HEIGHTS
 - STEEL PISTON WITH GREATER EFFECTIVE AREA
 - ALUMINUM PISTON

RECOMMENDED MAX. TORQUE VALUES

3/4"-16 UNC COMBO STUD	1/2"-13 UNC TOP STUD	1/2"-13 UNC BEAD TAP TYP. OF (4)	1/4"-18 UNC AIR FITTING
600 in-lb 50 ft-lb	300 in-lb 25 ft-lb	600 in-lb 50 ft-lb	240 in-lb 20 ft-lb
3/4"-10 UNC LIX LOCKNUT			
800 in-lb 75 ft-lb			

NOTE: SEE GUIDELINES FOR PROPER APPLICATION OF THIS PRODUCT

LOAD vs. DEFLECTION @ CONSTANT PRESSURE

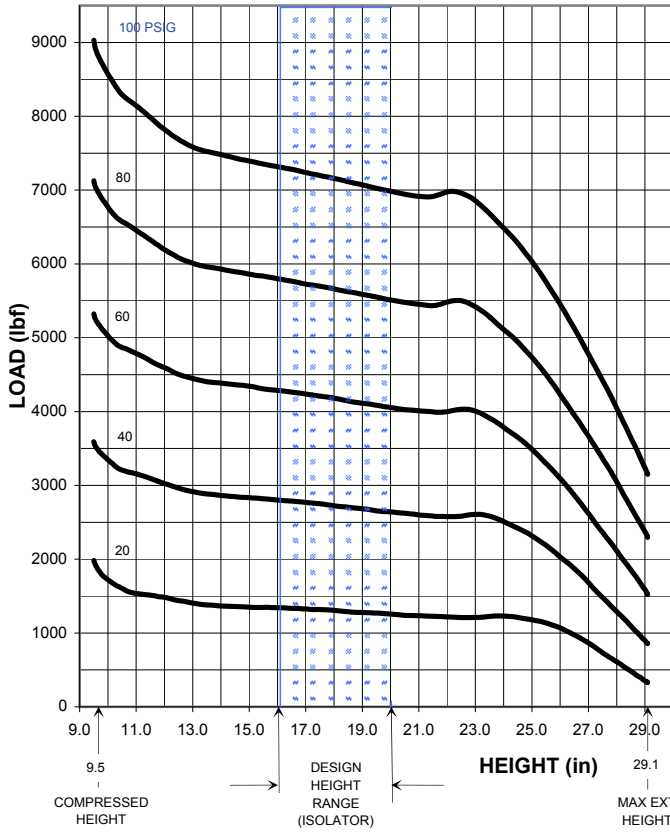

DYNAMIC DATA @ 18.0 in DESIGN HEIGHT

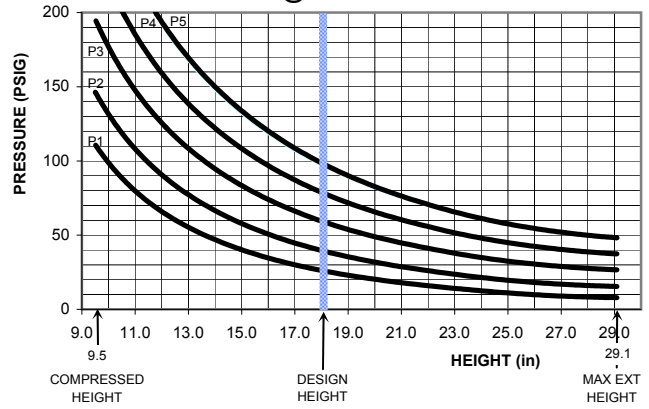

DYNAMIC DATA @ 18.0 in DESIGN HEIGHT

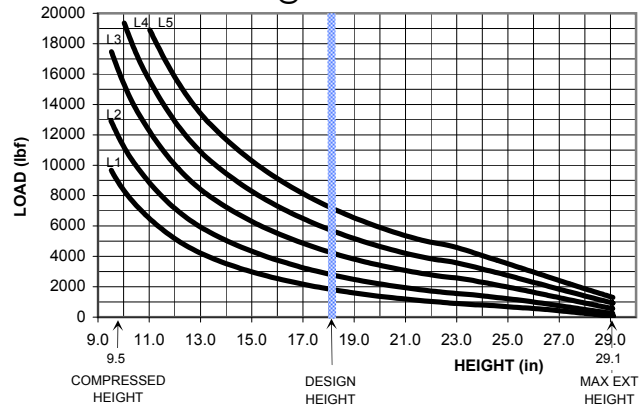

****NOTE: MAXIMUM INFLATION PRESSURE IS 100 PSIG. MAXIMUM JOUNCE PRESSURE IS 200 PSIG. IF YOUR APPLICATION WILL EXCEED THESE LIMITS, CONSULT A GOODYEAR ENGINEERED PRODUCTS AIR SPRINGS REPRESENTATIVE FOR APPLICATION ASSISTANCE.**

CONSTANT PRESSURE CHARACTERISTICS

Assembly Height (in)	Meniscus Height "M" Dim. @ 100 PSIG (in)	Volume @ 100 PSIG (in ³)	Nominal Force (lb)				
			@ 20 PSIG	@ 40 PSIG	@ 60 PSIG	@ 80 PSIG	@ 100 PSIG
29.1	8.1	1760	320	850	1500	2200	3100
26.0	7.6	1596	1100	2000	3100	4300	5500
24.0	7.2	1462	1300	2500	3900	5200	6500
22.0	6.5	1317	1300	2600	4000	5500	7000
20.0	5.2	1174	1350	2600	4100	5500	7000
18.0	4.1	1036	1400	2700	4200	5600	7200
16.0	2.9	899	1450	2800	4300	5800	7300
14.0	1.7	767	1500	2900	4400	5900	7500
12.0	0.7	640	1500	3000	4600	6200	7800
9.5	0.0	429	1900	3400	5100	7100	9000

DYNAMIC CHARACTERISTICS

Design Height (in)	Load (lb)	Pressure (PSIG)	Spring Rate (lb/in)	Natural Frequency	
				cpm	Hz
20.0	2000	28	270	69	1.15
	3000	42	350	64	1.07
	4500	63	465	60	1.00
	6000	83	580	58	0.97
18.0	2000	28	290	71	1.18
	3000	42	405	69	1.15
	4500	62	535	65	1.08
	6000	81	655	62	1.03
16.0	7500	100	790	61	1.02
	2000	27	345	78	1.30
	3000	41	455	73	1.22
	4500	61	600	69	1.15
16.0	6000	80	770	67	1.12
	7500	99	910	65	1.08

The GOODYEAR (and Winged Foot Design) trademark is used by Veyance Technologies, Inc. under license from The Goodyear Tire & Rubber Company. Goodyear Engineered Products are manufactured and sourced exclusively by Veyance Technologies, Inc. or its affiliates. The following trademarks are licensed to Veyance Technologies, Inc. by The Goodyear Tire & Rubber Company, including Compass, Eagle Pd, Flexten, Gatorback and GY Metric. ©2008 Veyance Technologies, Inc. All Rights Reserved.



1R12-274

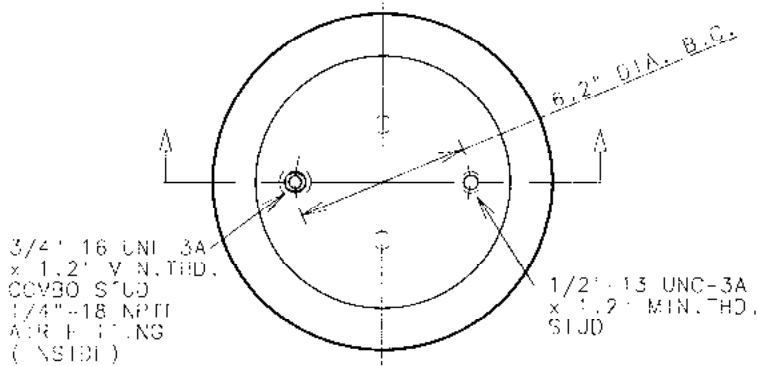

TOP VIEW

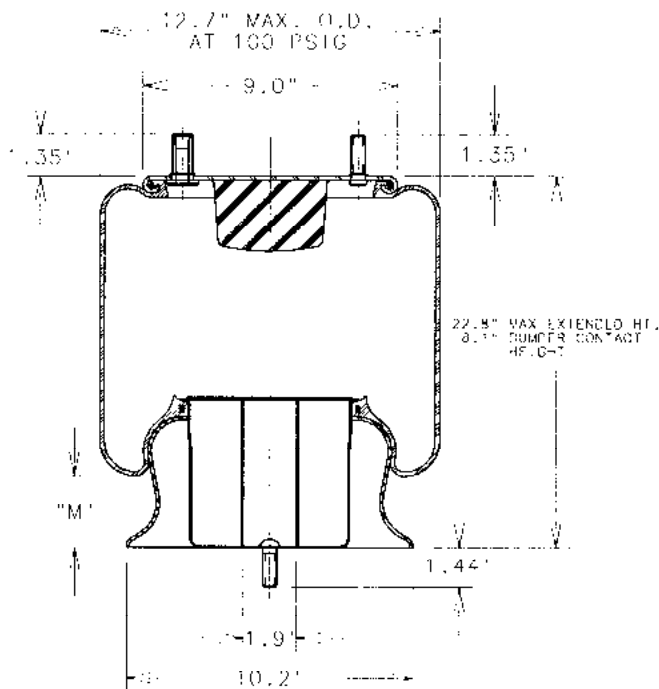

SIDE VIEW

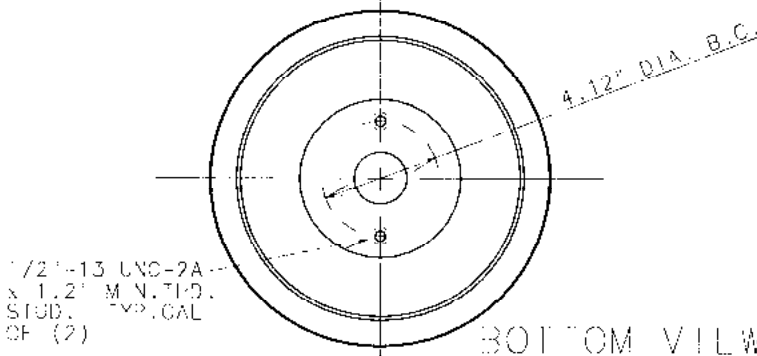

BOTTOM VIEW

ASSEMBLY NUMBER	ELASTOMER	AIR FITTING	BUMPER INCLUDED
1R12-274	NAT. RUBBER	1/4"-18 NPTF COMBO STUD	YES

SPRING FEATURES:

- LOAD RANGE (ISOLATOR).....1450-7100 lb
- DESIGN HEIGHT RANGE (ISOLATOR).....11.5-14.3 in
- USABLE STROKE (ACTUATOR).....14.7 in
- ASSEMBLY WEIGHT.....20.3 lb
- STEEL PISTON

OTHER OPTIONS:

- METRIC ATTACHMENTS
- UPPER HEAD PLATE:
 - ALTERNATE BOLT LENGTHS AND SPACINGS
 - ALTERNATE AIR FITTING SIZES AND LOCATIONS
 - NO BUMPER OR ALTERNATE BUMPER
- PISTON:
 - ALUMINUM PISTONS WITH LOWER SPRING RATES

RECOMMENDED MAX. TORQUE VALUES

3/4"-16 UNF COMBO STUD	1/2"-13 UNC TOP STUD	1/2"-13 UNC BOTTOM STUD TYP. OF (2)	1/4"-18 UNC AIR FITTINGS
600 in-lb 50 ft-lb	300 in-lb 25 ft-lb	300 in-lb 25 ft-lb	240 in-lb 20 ft-lb

NOTE: SEE OUR DELINEATIONS FOR PROPER APPLICATION OF THIS PRODUCT

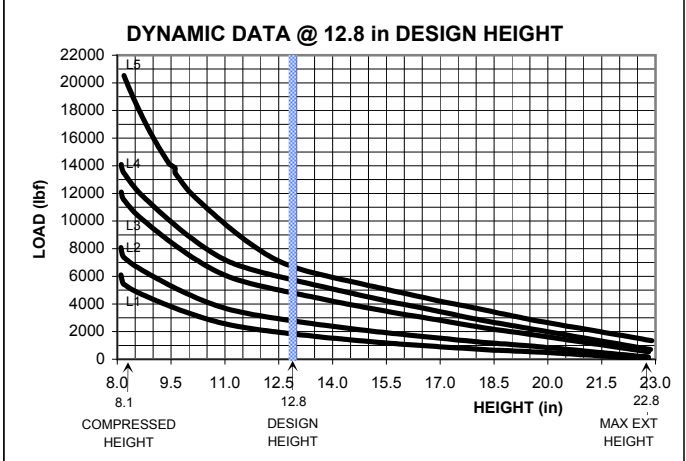
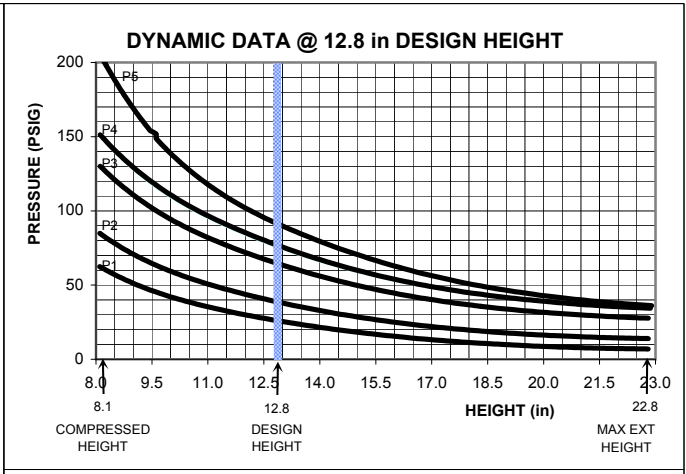
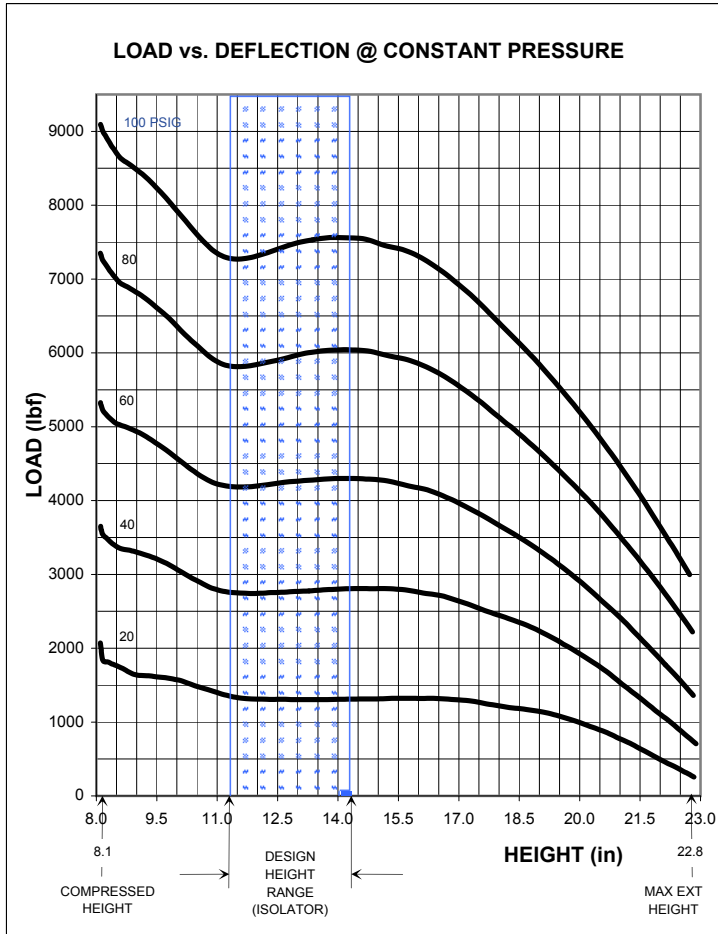

****NOTE: MAXIMUM INFLATION PRESSURE IS 100 PSIG. MAXIMUM JOUNCE PRESSURE IS 200 PSIG. IF YOUR APPLICATION WILL EXCEED THESE LIMITS, CONSULT A GOODYEAR ENGINEERED PRODUCTS AIR SPRINGS REPRESENTATIVE FOR APPLICATION ASSISTANCE.**

CONSTANT PRESSURE CHARACTERISTICS

Assembly Height (in)	Meniscus Height "M" Dim. @ 100 PSIG (in)	Volume @ 100 PSIG (in ³)	Nominal Force (lb)				
			@ 20 PSIG	@ 40 PSIG	@ 60 PSIG	@ 80 PSIG	@ 100 PSIG
22.8	4.8	1717	300	750	1450	2200	3000
22.0	4.8	1684	500	1150	1900	2900	3700
20.0	4.7	1574	1050	2000	2900	4200	5200
18.0	4.1	1419	1250	2500	3600	5100	6400
16.0	3.5	1248	1450	2700	4100	5800	7300
14.3	2.9	1111	1450	2800	4300	6000	7500
12.8	2.0	969	1400	2800	4200	6000	7500
11.3	1.0	864	1400	2700	4100	5800	7300
10.0	0.4	756	1600	2900	4500	6400	8000
8.1	0.0	630	1700	3500	5200	7200	9000

DYNAMIC CHARACTERISTICS

Design Height (in)	Load (lb)	Pressure (PSIG)	Spring Rate (lb/in)	Natural Frequency	
				cpm	Hz
14.3	2000	26	315	75	1.25
	3000	39	420	71	1.18
	5000	65	635	67	1.12
	6000	78	725	66	1.10
12.8	2000	27	315	74	1.23
	3000	40	405	69	1.15
	5000	67	565	63	1.05
	6000	79	640	61	1.02
11.3	2000	28	395	83	1.38
	3000	41	485	75	1.25
	5000	69	725	71	1.18
	6000	82	805	69	1.15
10.0	7000	92	700	59	0.98
	7000	94	880	67	1.12

The GOODYEAR (and Winged Foot Design) trademark is used by Veyance Technologies, Inc. under license from The Goodyear Tire & Rubber Company. Goodyear Engineered Products are manufactured and sourced exclusively by Veyance Technologies, Inc. or its affiliates. The following trademarks are licensed to Veyance Technologies, Inc. by The Goodyear Tire & Rubber Company, including Compass, Eagle Pd, Flexten, Gatorback and GY Metric. ©2008 Veyance Technologies, Inc. All Rights Reserved.



1R14-018

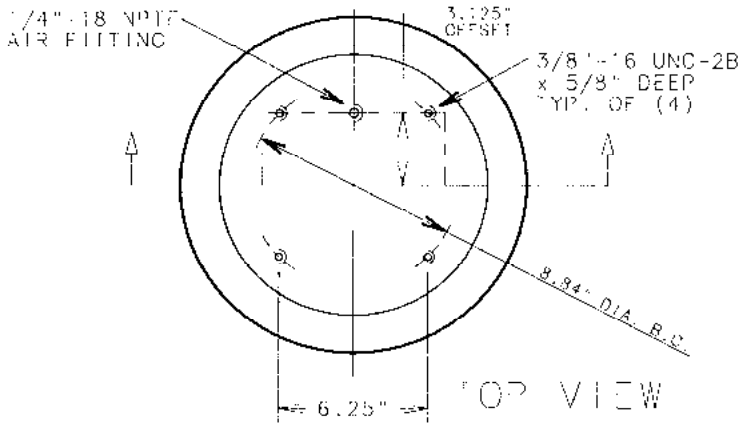

14.6 MAX. U.D. AT 100 PSIG

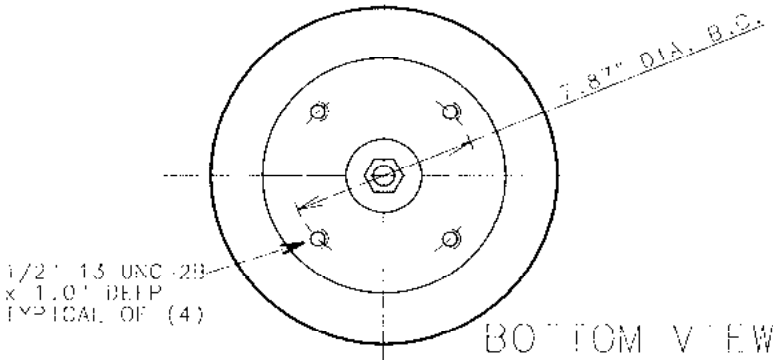
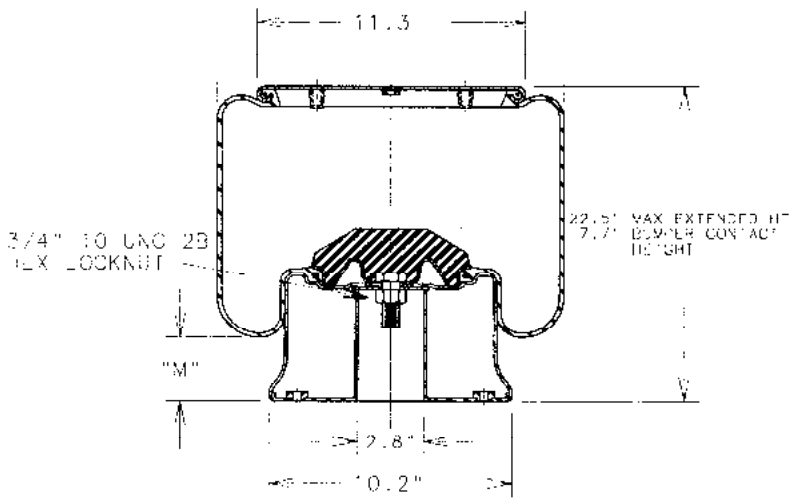

ASSEMBLY NUMBER	ELASTOMER	AIR FITTING	BUMPER NO. USED
1R14-018	NAT. RUBBER	1/4"-18 NPTF OFFSET 3.125"	YES

SPRING FEATURES:

- LOAD RANGE (ISOLATOR).....1500-6500 lb
- DESIGN HEIGHT RANGE (ISOLATOR).....11.0-16.5 in
- USEABLE STROKE (ACTUATOR).....14.8 in
- ASSEMBLY WEIGHT.....26.9 lb
- STEEL PISTON

OTHER OPTIONS:

- WELD ON ATTACHMENTS
- UPPER BEAD PLATE:
 - ALTERNATE BOLT LENGTHS AND SPACINGS
 - ALTERNATE AIR FITTING SIZES AND LOCATIONS
 - NO BUMPER OR ALTERNATE BUMPER
- PISTON:
 - ALTERNATE HEIGHTS
 - ALUMINUM PISTON

RECOMMENDED MAX. TORQUE VALUES

3/8"-16 UNC BLIND TAP TYP. OF (4)	1/2"-13 UNC BLIND TAP TYP. OF (4)	1/4"-18 UNC AIR FITTING	5/4"-10 UNC HEX LOCKNUT
300 in-lb 25 ft-lb	600 in-lb 50 ft-lb	240 in-lb 20 ft-lb	600 in-lb 75 ft-lb

NOTE: SEE GUIDELINES FOR PROPER APPLICATION OF THIS PRODUCT

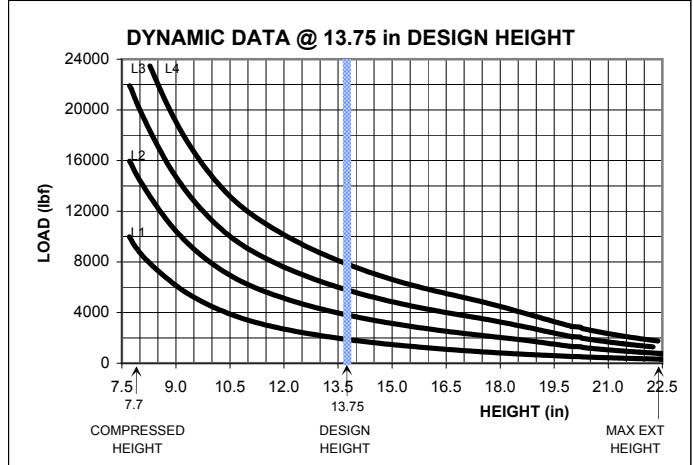
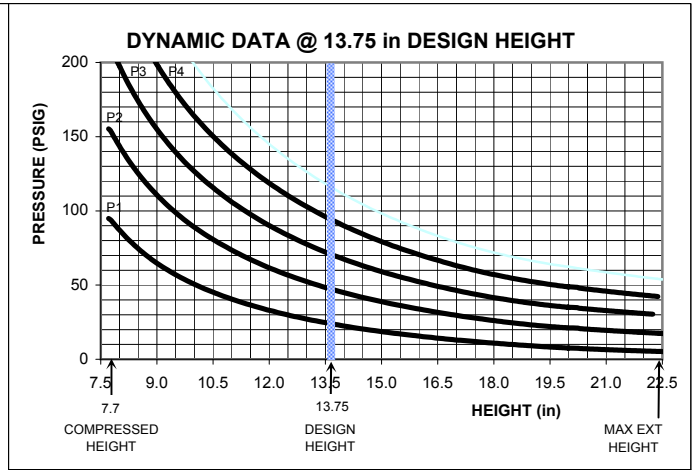
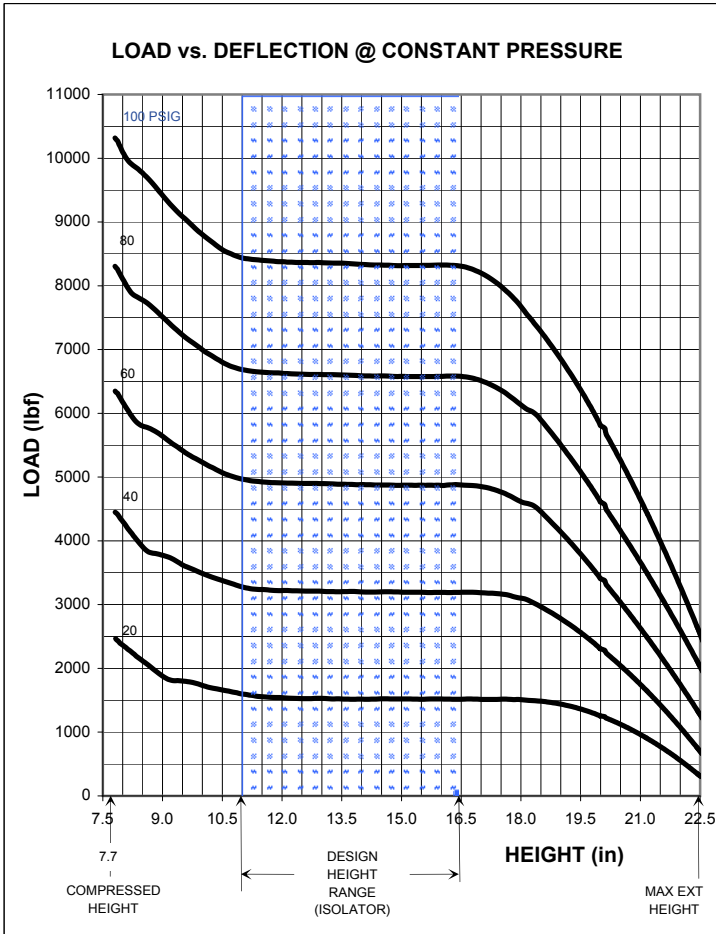

****NOTE: MAXIMUM INFLATION PRESSURE IS 100 PSIG. MAXIMUM JOUNCE PRESSURE IS 200 PSIG. IF YOUR APPLICATION WILL EXCEED THESE LIMITS, CONSULT A GOODYEAR ENGINEERED PRODUCTS AIR SPRINGS REPRESENTATIVE FOR APPLICATION ASSISTANCE.**

CONSTANT PRESSURE CHARACTERISTICS

Assembly Height (in)	Meniscus Height "M" Dim. @ 100 PSIG (in)	Volume @ 100 PSIG (in ³)	Nominal Force (lb)				
			@ 20 PSIG	@ 40 PSIG	@ 60 PSIG	@ 80 PSIG	@ 100 PSIG
22.5	5.7	1750	300	680	1250	2000	2500
20.0	5.7	1529	1250	2300	3400	4600	5800
18.0	5.4	1355	1500	3100	4700	6200	7600
16.5	4.5	1208	1500	3100	4900	6500	8400
15.0	3.8	1064	1600	3100	4900	6500	8400
13.75	3.0	950	1600	3100	4900	6600	8400
12.0	1.9	799	1600	3200	5000	6600	8400
11.0	1.3	715	1600	3300	5000	6600	8500
9.0	0.4	554	1800	3800	5700	7500	9500
7.7	0.0	409	2400	4700	6600	8300	10300

DYNAMIC CHARACTERISTICS

Design Height (in)	Load (lb)	Pressure (PSIG)	Spring Rate (lb/in)	Natural Frequency	
				cpm	Hz
16.5	2000	24	320	75	1.25
	4000	49	540	69	1.15
	6000	72	755	94	1.57
13.75	8000	94	970	66	1.10
	2000	25	385	82	1.37
	4000	48	625	74	1.23
11.0	6000	72	875	72	1.20
	2000	24	640	106	1.77
	4000	49	970	92	1.53
9.0	6000	72	1260	86	1.43
	8000	95	1550	83	1.38

The GOODYEAR (and Winged Foot Design) trademark is used by Veyance Technologies, Inc. under license from The Goodyear Tire & Rubber Company. Goodyear Engineered Products are manufactured and sourced exclusively by Veyance Technologies, Inc. or its affiliates. The following trademarks are licensed to Veyance Technologies, Inc. by The Goodyear Tire & Rubber Company, including Compass, Eagle Pd, Flexten, Gatorback and GY Metric. ©2008 Veyance Technologies, Inc. All Rights Reserved.



1R14-019

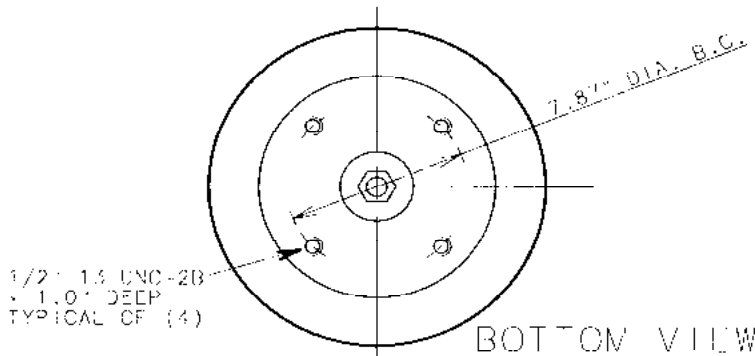
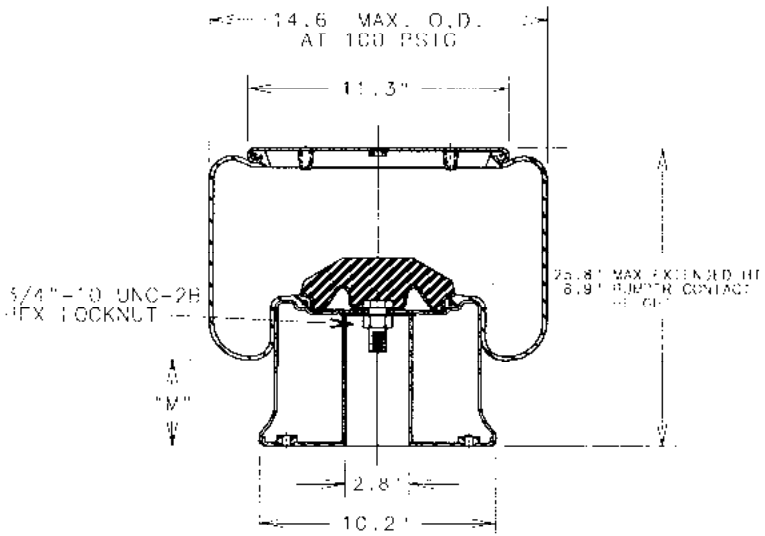
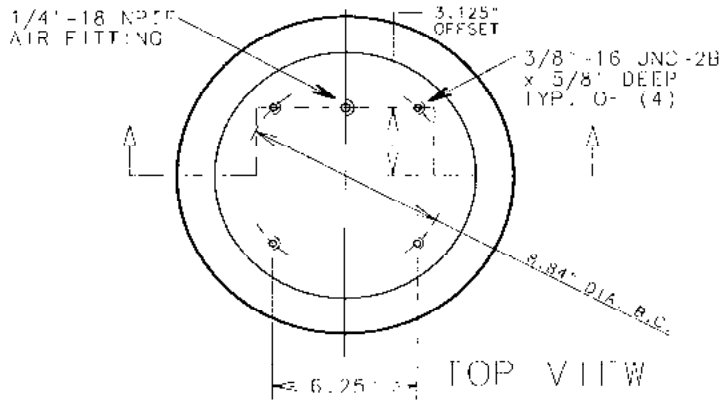

ASSEMBLY NUMBER	ELASTOMER	AIR FITTING	BUMPER INCLUDED
1R14-019	NAT. RUBBER	1/4" - 18 NPTF OFFSET 3.125"	YES

SPRING FEATURES:

- LOAD RANGE (ISOLATOR).....1500-8500 lb
- DESIGN HEIGHT RANGE (ISOLATOR)....14.0-18.0 in
- USHAR. F. STROKE (ACTUATOR).....16.0 in
- ASSEMBLY WEIGHT.....29.0 lb
- STEEL PLATE

OTHER OPTIONS:

- METRIC ATTACHMENTS
- ALTERNATE BOLT LENGTHS AND SPACINGS
- ALTERNATE AIR FITTING SIZES AND LOCATIONS
- NO BUMPER OR ALTERNATE BUMPER
- ALUMINUM PLATE
- ALTERNATE HEIGHTS

RECOMMENDED MAX. TORQUE VALUES

3/8" - 16 UNC BLIND TAP TYP. OF (4)	1/2" - 15 UNC BLIND TAP TYP. OF (4)	1/4" - 18 UNC AIR FITTING	3/4" - 10 UNC HEX LOCKNUT
300 in-lb 25 ft-lb	600 in-lb 50 ft-lb	240 in-lb 20 ft-lb	900 in-lb 75 ft-lb

NOTE: SEE GUIDELINES FOR PROPER APPLICATION OF THIS PRODUCT

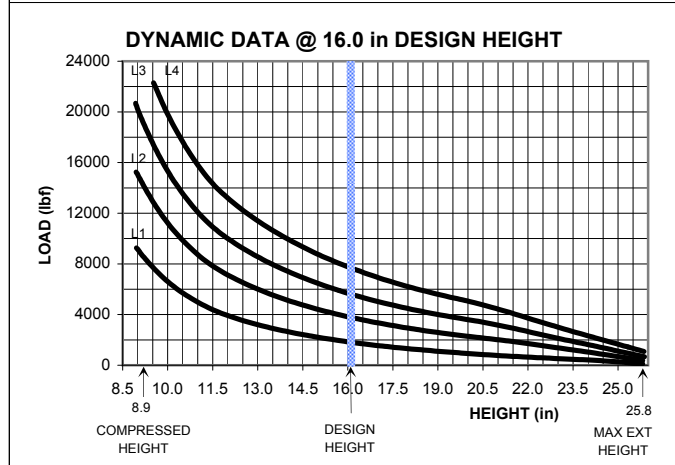
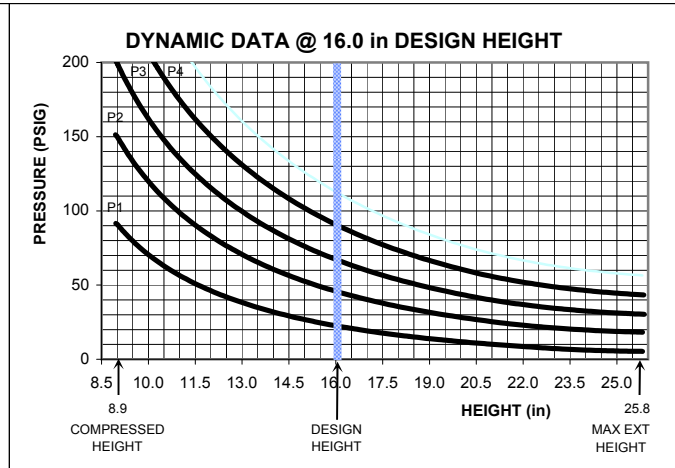
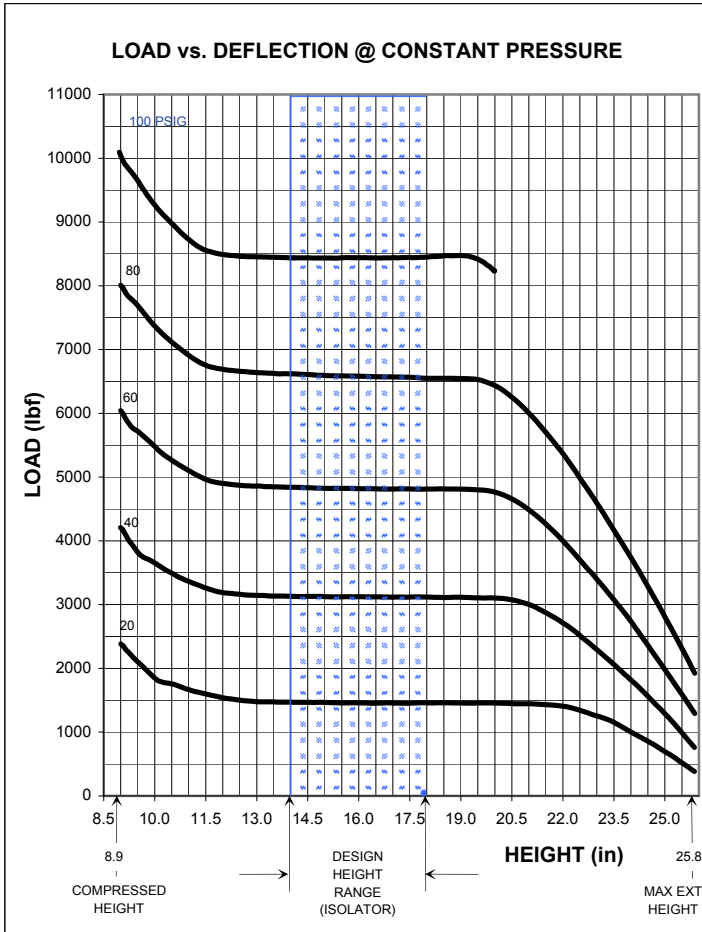

****NOTE: MAXIMUM INFLATION PRESSURE IS 100 PSIG. MAXIMUM JOUNCE PRESSURE IS 200 PSIG. IF YOUR APPLICATION WILL EXCEED THESE LIMITS, CONSULT A GOODYEAR ENGINEERED PRODUCTS AIR SPRINGS REPRESENTATIVE FOR APPLICATION ASSISTANCE.**

CONSTANT PRESSURE CHARACTERISTICS

Assembly Height (in)	Meniscus Height "M" Dim. @ 100 PSIG (in)	Volume @ 100 PSIG (in ³)	Nominal Force (lb)				
			@ 20 PSIG	@ 40 PSIG	@ 60 PSIG	@ 80 PSIG	@ 100 PSIG
25.8	6.9	1980	480	800	1300	2000	--
25.0	6.9	1906	700	1300	2000	2800	--
23.0	6.8	1782	1300	2300	3500	4500	--
21.0	6.7	1619	1400	3000	4500	6000	--
18.0	5.2	1334	1500	3100	4800	6500	8500
16.0	4.1	1152	1500	3100	4800	6500	8500
14.0	3.0	977	1500	3100	4800	6600	8500
12.0	1.8	811	1500	3100	4900	6700	8500
11.0	1.2	731	1700	3400	5000	6900	8900
8.9	0.3	566	2500	4200	6000	8000	10100

DYNAMIC CHARACTERISTICS

Design Height (in)	Load (lb)	Pressure (PSIG)	Spring Rate (lb/in)	Natural Frequency	
				cpm	Hz
18.0	2000	24	300	72	1.20
	4000	47	465	64	1.07
	6000	71	640	61	1.02
16.0	8000	93	810	60	1.00
	2000	24	330	76	1.27
	4000	47	545	69	1.15
14.0	6000	69	720	66	1.10
	8000	92	910	64	1.07
	2000	24	390	83	1.38
14.0	4000	48	660	76	1.27
	6000	71	875	72	1.20
	8000	93	1075	69	1.15

The GOODYEAR (and Winged Foot Design) trademark is used by Veyance Technologies, Inc. under license from The Goodyear Tire & Rubber Company. Goodyear Engineered Products are manufactured and sourced exclusively by Veyance Technologies, Inc. or its affiliates. The following trademarks are licensed to Veyance Technologies, Inc. by The Goodyear Tire & Rubber Company, including Compass, Eagle Pd, Flexten, Gatorback and GY Metric. ©2008 Veyance Technologies, Inc. All Rights Reserved.



1R14-037

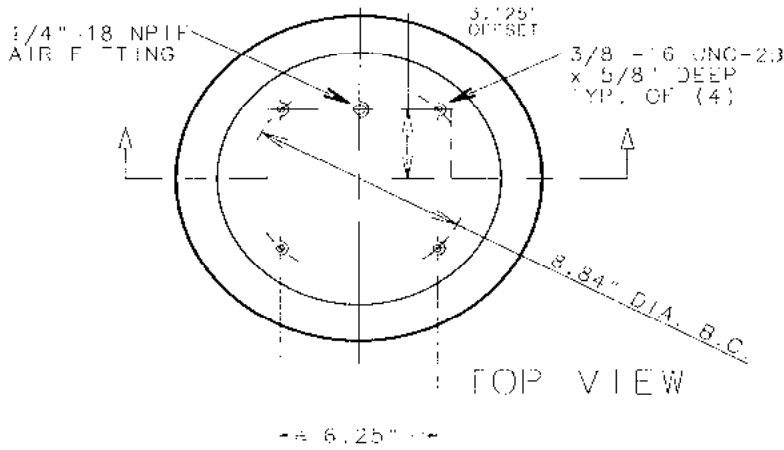

ASSEMBLY NUMBER	ELASTOMER	AIR FITTING	BUMPER INCLUDED
1R14-037	NAT. RUBBER	1/4" - 18 NPTT OFFSET 3.125"	YES

SPRING FEATURES:

- LOAD RANGE (ISOLATOR).....1900-11000 lb
- DESIGN HEIGHT RANGE (ISOLATOR).....7.5-11.0 in
- USEABLE STROKE (ACTUATOR).....12.5 in
- ASSEMBLY WEIGHT.....22.9 lb
- ALUMINUM PISTON

OTHER OPTIONS:

- METRIC ATTACHMENTS
- UPPER BLAD PLATE:
 - ALTERNATE BOLT LENGTHS AND SPACINGS
 - ALTERNATE AIR FITTING SIZES AND LOCATIONS
 - NO BUMPER OR ALTERNATE BUMPER
- PISTON:
 - ALTERNATE HEIGHTS
 - STEEL PISTON WITH LESS EFFECTIVE AREA

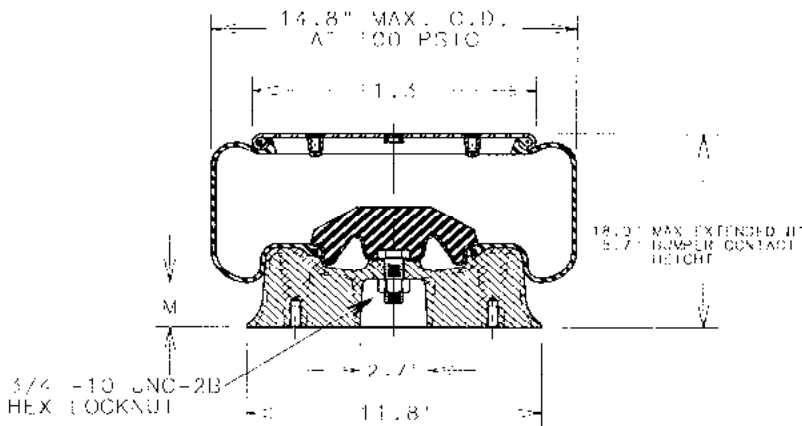

SIDE VIEW

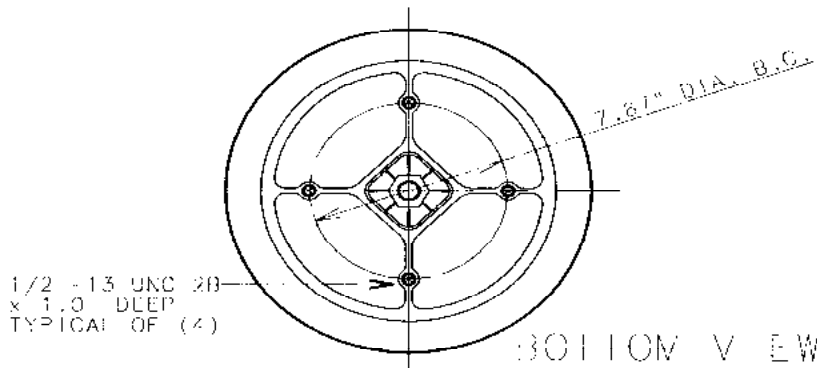

BOTTOM VIEW

RECOMMENDED MAX. TORQUE VALUES

5/8" - 16 UNC BLIND TAP TYP. OF (4)	1/2" - 13 UNC BLIND TAP TYP. OF (4)	1/4" - 18 UNC AIR FITTING	3/4" - 10 UNC HEX LOCKNUT
500 in-lb 25 ft-lb	600 in-lb 50 ft-lb	240 in-lb 20 ft-lb	900 in-lb 75 ft-lb

NOTE: SEE GUIDELINES FOR PROPER APPLICATION OF THIS PRODUCT

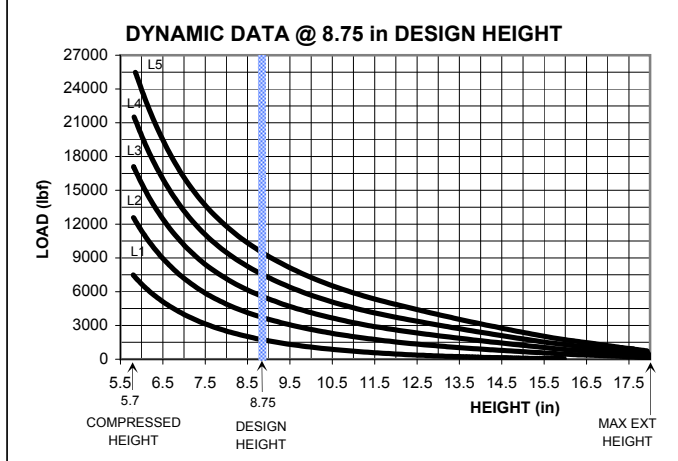
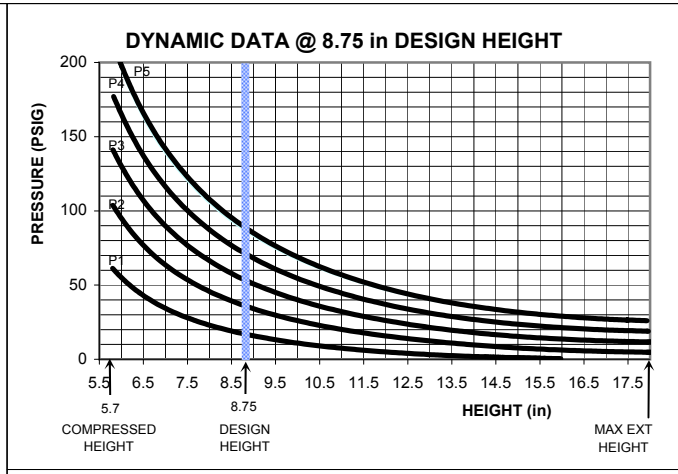
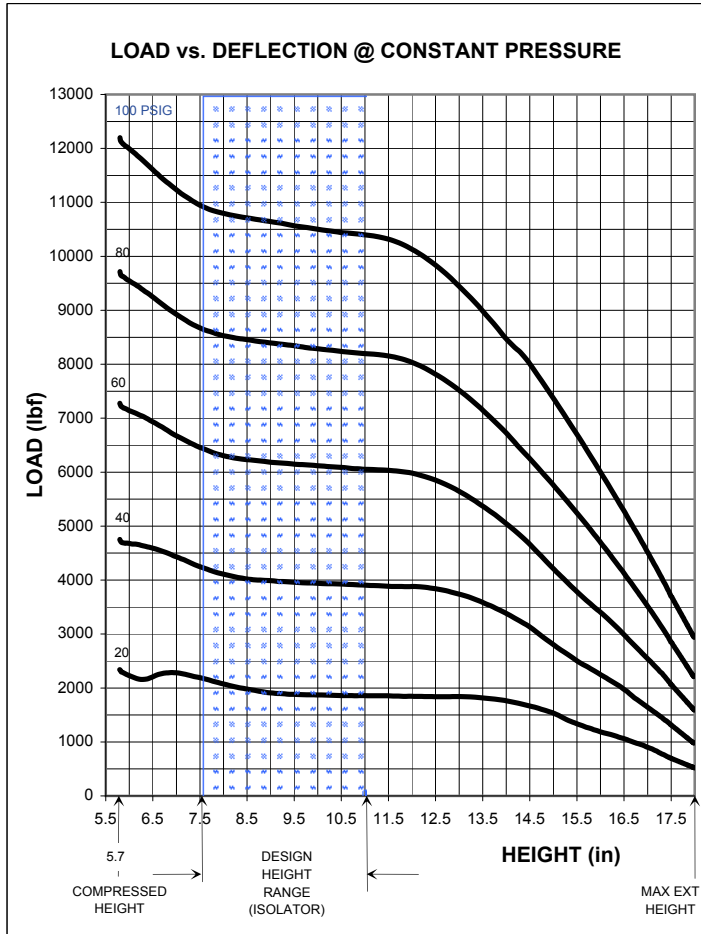

****NOTE: MAXIMUM INFLATION PRESSURE IS 100 PSIG. MAXIMUM JOUNCE PRESSURE IS 200 PSIG. IF YOUR APPLICATION WILL EXCEED THESE LIMITS, CONSULT A GOODYEAR ENGINEERED PRODUCTS AIR SPRINGS REPRESENTATIVE FOR APPLICATION ASSISTANCE.**

CONSTANT PRESSURE CHARACTERISTICS

Assembly Height (in)	Meniscus Height "M" Dim. @ 100 PSIG (in)	Volume @ 100 PSIG (in ³)	Nominal Force (lb)				
			@ 20 PSIG	@ 40 PSIG	@ 60 PSIG	@ 80 PSIG	@ 100 PSIG
18.0	3.6	1653	480	950	1500	2200	2900
16.0	3.6	1447	1200	2200	3400	4600	5900
14.0	3.5	1246	1800	3400	5000	6600	8500
12.0	3.0	1011	1800	3900	6000	8100	10100
11.0	2.5	893	1900	4000	6000	8200	10400
10.0	2.0	780	1900	4000	6100	8400	10500
8.75	1.3	676	1900	4000	6200	8500	10600
7.5	0.6	518	2100	4200	6500	8600	11000
7.0	0.3	469	2300	4500	6600	9000	11400
5.7	0.0	354	2400	4700	7300	9800	12200

DYNAMIC CHARACTERISTICS

Design Height (in)	Load (lb)	Pressure (PSIG)	Spring Rate (lb/in)	Natural Frequency	
				cpm	Hz
11.0	2000	20	530	96	1.60
	4000	39	865	87	1.45
	6000	57	1155	83	1.38
	8000	76	1495	81	1.35
8.75	10000	95	1830	80	1.33
	2000	19	810	120	2.00
	4000	38	1250	104	1.73
	6000	56	1630	98	1.63
	8000	75	2040	95	1.58
7.5	10000	92	2430	93	1.55
	2000	17	1025	134	2.23
	4000	36	1660	121	2.02
	6000	54	2330	115	1.92
	8000	73	2735	110	1.83
	10000	91	3275	107	1.78

The GOODYEAR (and Winged Foot Design) trademark is used by Veyance Technologies, Inc. under license from The Goodyear Tire & Rubber Company. Goodyear Engineered Products are manufactured and sourced exclusively by Veyance Technologies, Inc. or its affiliates. The following trademarks are licensed to Veyance Technologies, Inc. by The Goodyear Tire & Rubber Company, including Compass, Eagle Pd, Flexten, Gatorback and GY Metric. ©2008 Veyance Technologies, Inc. All Rights Reserved.



1S3-011

3/4"-16 UNF-2A
x 5/8" MIN. I.D.
COMBO STUD
1/8"-27 NPTF
AIR FITTING
(INSIDE)

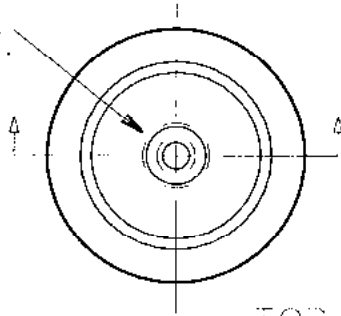

TOP VIEW

TOP AND BOTTOM
SURFACE TO BE
FULLY SUPPORTED
TO 2.75" O.A.

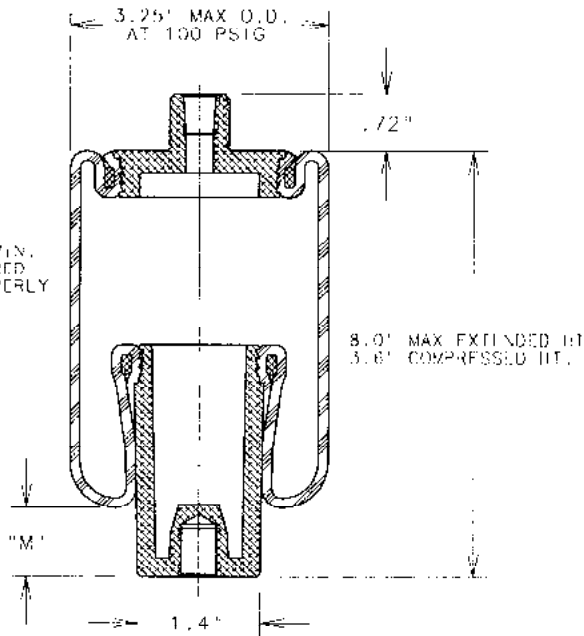

SIDE VIEW

NOTE: 10 PSIG MIN.
PRESSURE REQUIRED
TO OPERATE PROPERLY

8.0" MAX EXTENDED HT.
3.6" COMPRESSED HT.

1/2"-13 UNC-2B
x 5/8" DEEP

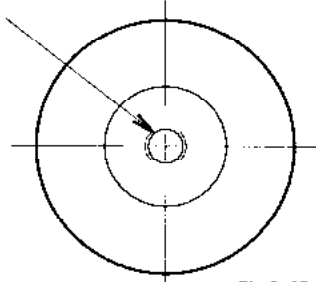

BOTTOM VIEW

ASSEMBLY NUMBER	ELASTOMER	AIR FITTING	BUFFER INCLUDED
1S3-011	WINGSPRENE®	1/8"-27 NPTF COMBO STUD	NO

SPRING FEATURES:

- LOAD RANGE (ISOLATOR).....70-400 lb
- DESIGN HEIGHT RANGE (ISOLATOR).....5.0-6.0 in
- USEABLE STROKE (ACTUATOR).....4.4 in
- ASSEMBLY WEIGHT.....1.4 lb
- DISCASED END COMPONENTS

RECOMMENDED MAX. TORQUE VALUES

1/2"-13 UNC BLIND TAP	3/4"-16 UNF COMBO STUD	1/8"-27 UNC AIR FITTING
360 in-lb 30 ft-lb	360 in-lb 30 ft-lb	180 in-lb 15 ft-lb

NOTE: SEE GUIDELINES FOR PROPER APPLICATION OF THIS PRODUCT

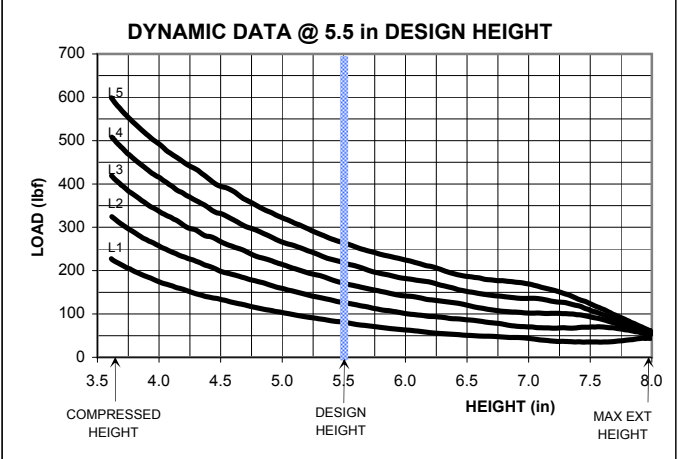
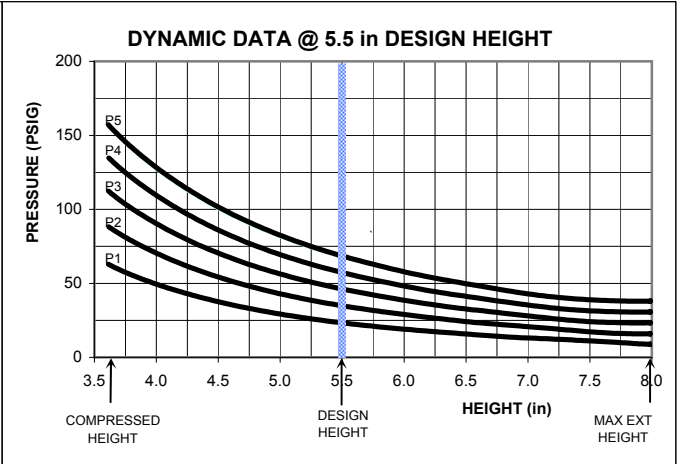
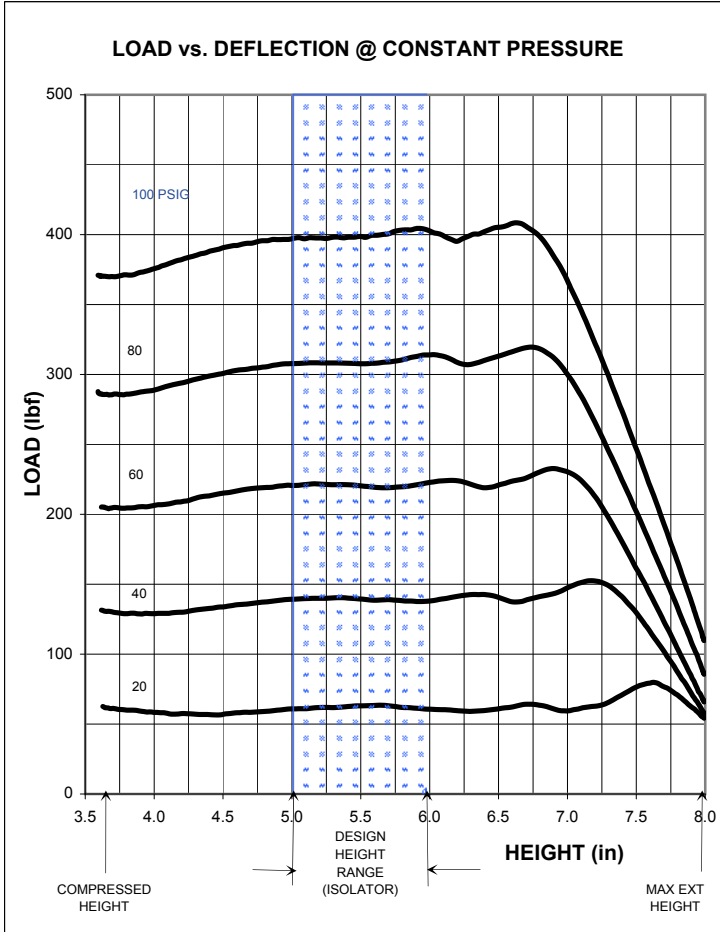

****NOTE: MAXIMUM INFLATION PRESSURE IS 100 PSIG. MAXIMUM JOUNCE PRESSURE IS 200 PSIG. IF YOUR APPLICATION WILL EXCEED THESE LIMITS, CONSULT A GOODYEAR ENGINEERED PRODUCTS AIR SPRINGS REPRESENTATIVE FOR APPLICATION ASSISTANCE.**

CONSTANT PRESSURE CHARACTERISTICS

Assembly Height (in)	Meniscus Height "M" Dim. @ 100 PSIG	Volume @ 100 PSIG (in ³)	Nominal Force (lb)				
			@ 20 PSIG	@ 40 PSIG	@ 60 PSIG	@ 80 PSIG	@ 100 PSIG
8.0	3.0	28	40	50	60	80	110
6.5	2.7	21	70	150	230	320	400
6.0	2.2	18	70	150	240	320	400
5.75	2.2	17	70	150	230	320	400
5.5	2.0	16	70	150	230	320	400
5.25	1.9	15	70	150	230	320	400
5.0	1.7	14	70	150	230	320	400
4.5	1.4	13	60	140	220	300	400
4.0	0.8	11	60	130	210	300	380
3.6	0.3	10	60	130	200	280	360

DYNAMIC CHARACTERISTICS

Design Height (in)	Load (lb)	Pressure (PSIG)	Spring Rate (lb/in)	Natural Frequency	
				cpm	Hz
6.0	80	25	35	111	1.85
	125	37	55	114	1.90
	170	48	70	111	1.85
	215	60	85	110	1.83
5.5	260	72	100	108	1.80
	80	26	45	124	2.07
	125	38	60	119	1.98
	170	50	75	114	1.90
5.0	215	62	85	111	1.85
	260	74	105	110	1.83
	80	26	45	125	2.08
	125	39	65	123	2.05
5.0	170	50	85	122	2.03
	215	62	100	120	2.00
5.0	260	74	120	118	1.97

The GOODYEAR (and Winged Foot Design) trademark is used by Veyance Technologies, Inc. under license from The Goodyear Tire & Rubber Company. Goodyear Engineered Products are manufactured and sourced exclusively by Veyance Technologies, Inc. or its affiliates. The following trademarks are licensed to Veyance Technologies, Inc. by The Goodyear Tire & Rubber Company, including Compass, Eagle Pd, Flexten, Gatorback and GY Metric. ©2008 Veyance Technologies, Inc. All Rights Reserved.



1S3-013

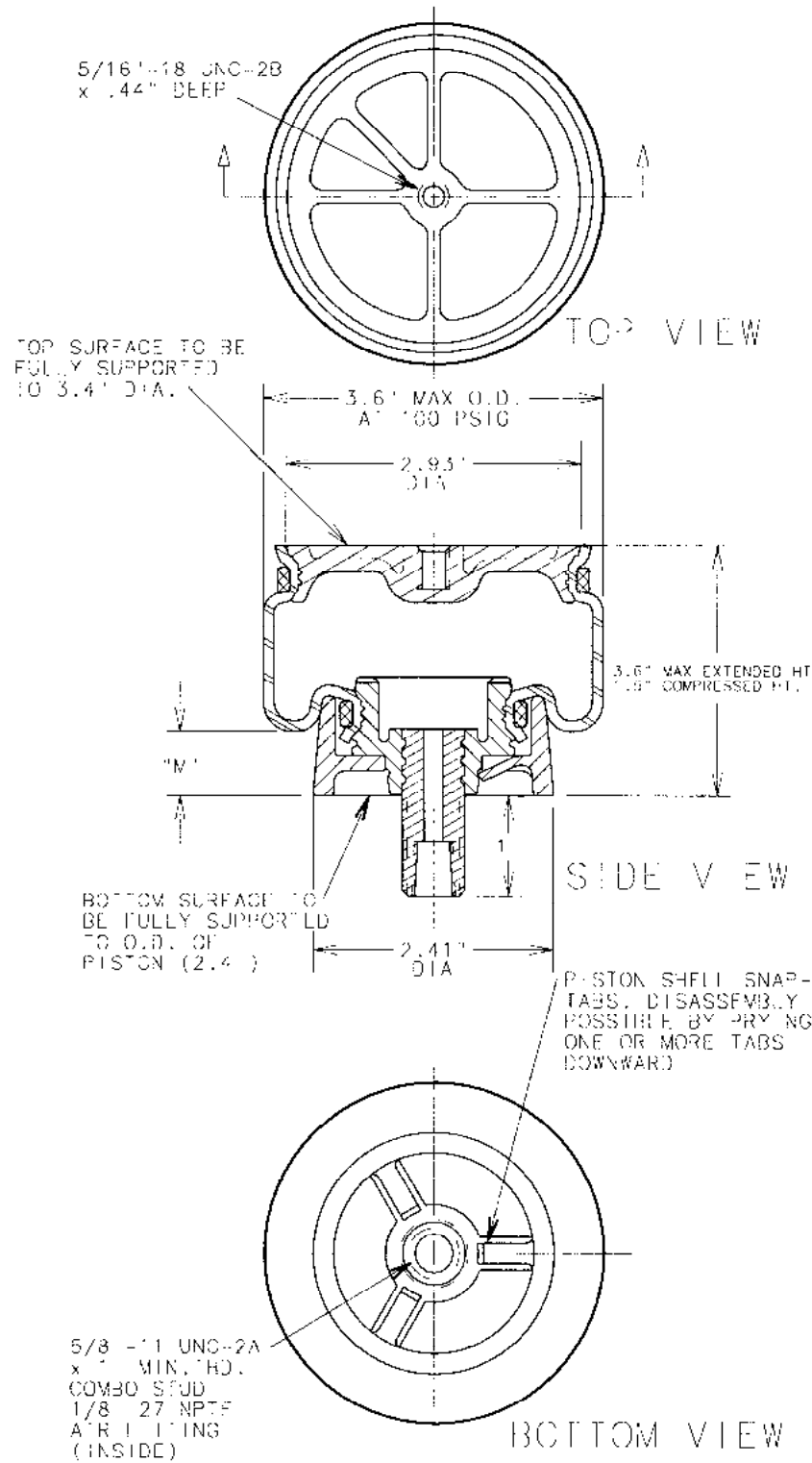

ASSEMBLY NUMBER	ELASTOMER	AIR FITTING	BUFFER INCLUDED
1S3-013	WINOPRENE®	1/8"-27 NPTF COMBO STUD	NO

SPRING FEATURES:

- LOAD RANGE (ISOLATOR).....90-580 lb
- DESIGN HEIGHT RANGE (ISOLATOR).....2.0-3.0 in
- USEABLE STROKE (ACTUATOR).....2.1 in
- ASSEMBLY WEIGHT.....0.6 lb
- FORCE TO COMPRESS AT 0 PSIG.....8 lb
- LIGHT WEIGHT END RETAINERS (REINFORCED THERMOPLASTIC)
- ABUSE RESISTANT STEEL STUD

RECOMMENDED MAX. TORQUE VALUES

5/16"-18 UNC BLIND TAP	5/8"-11 UNC COMBO STUD	1/8"-27 UNC AIR FITTING
30-50 in-lb 2.5-4 ft-lb	300 in-lb 25 ft-lb	180 in-lb 15 ft-lb

NOTE: SEE GUIDELINES FOR PROPER APPLICATION OF THIS PRODUCT

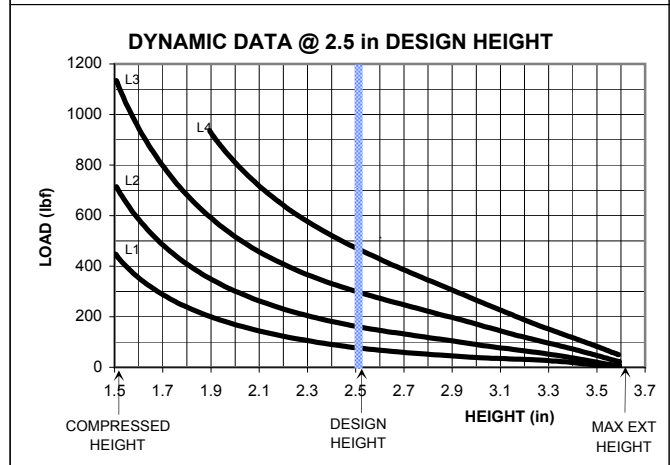
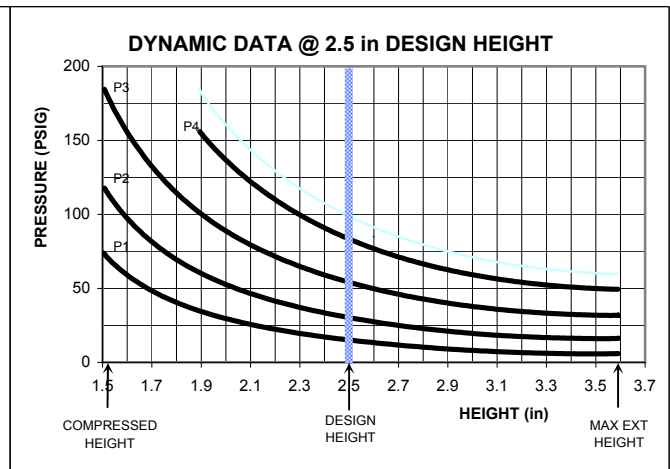
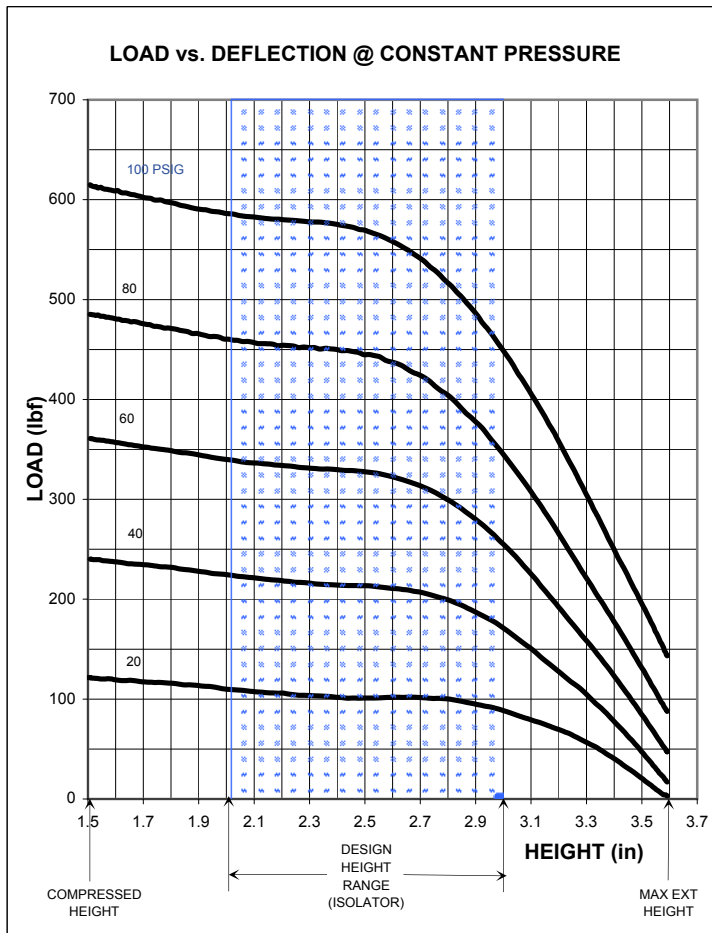

****NOTE: MAXIMUM INFLATION PRESSURE IS 100 PSIG. MAXIMUM JOUNCE PRESSURE IS 200 PSIG. IF YOUR APPLICATION WILL EXCEED THESE LIMITS, CONSULT A GOODYEAR ENGINEERED PRODUCTS AIR SPRINGS REPRESENTATIVE FOR APPLICATION ASSISTANCE.**

CONSTANT PRESSURE CHARACTERISTICS

Assembly Height (in)	Meniscus Height "M" Dim. @ 100 PSIG	Volume @ 100 PSIG (in ³)	Nominal Force (lb)				
			@ 20 PSIG	@ 40 PSIG	@ 60 PSIG	@ 80 PSIG	@ 100 PSIG
3.6	1.03	14.8	10	30	40	80	120
3.5	1.02	14.3	20	50	90	140	180
3.0	0.98	12.3	90	170	260	340	440
2.5	0.78	9.6	100	220	320	440	560
2.0	0.45	6.5	110	230	340	460	580
1.5	0.16	3.4	120	240	360	480	600

DYNAMIC CHARACTERISTICS

Design Height (in)	Load (lb)	Pressure (PSIG)	Spring Rate (lb/in)	Natural Frequency	
				cpm	Hz
3.0	80	21	160	236	3.93
	160	43	300	230	3.83
	300	77	495	223	3.72
2.5	80	18	145	224	3.73
	160	35	225	202	3.37
	300	61	370	194	3.23
2.0	460	88	520	191	3.18
	80	17	190	258	4.30
	160	34	300	231	3.85
	300	60	470	216	3.60
	460	85	610	208	3.47
	570	100	720	207	3.45

The GOODYEAR (and Winged Foot Design) trademark is used by Veyance Technologies, Inc. under license from The Goodyear Tire & Rubber Company. Goodyear Engineered Products are manufactured and sourced exclusively by Veyance Technologies, Inc. or its affiliates. The following trademarks are licensed to Veyance Technologies, Inc. by The Goodyear Tire & Rubber Company, including Compass, Eagle Pd, Flexten, Gatorback and GY Metric. ©2008 Veyance Technologies, Inc. All Rights Reserved.



1S4-007

3/8"-16 UNC-2B
x 1/2" DEEP

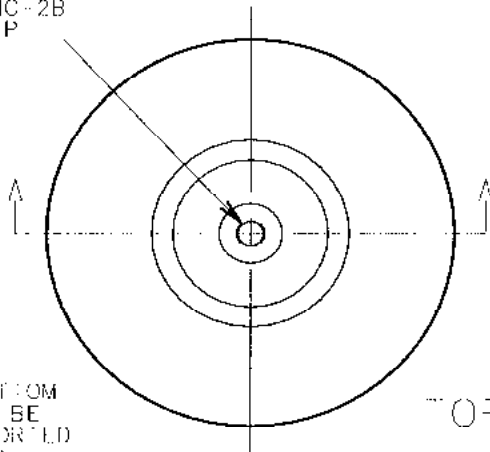

TOP VIEW

TOP AND BOTTOM SURFACE TO BE FULLY SUPPORTED TO 4.1" D.I.A.

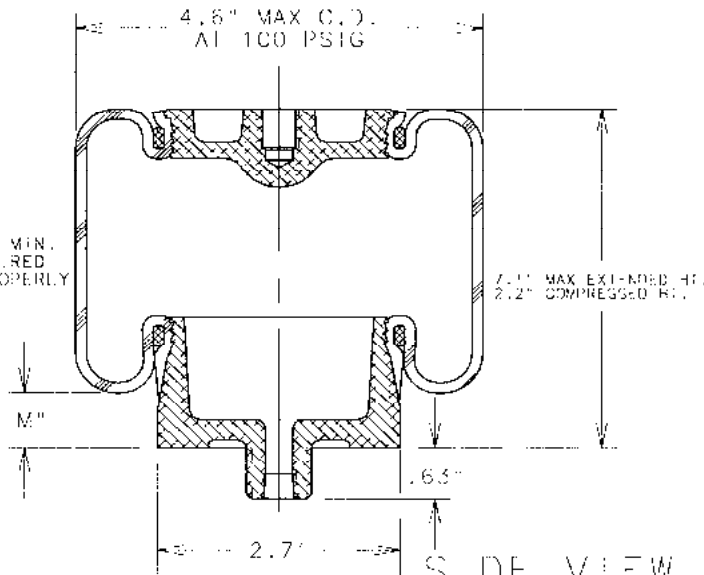

SIDE VIEW

3/4"-16 UNF-2A
x 9/16" MIN. I.D.
COMBO STUD
1/8"-27 NPT
AIR FITTING
(INSIDE)

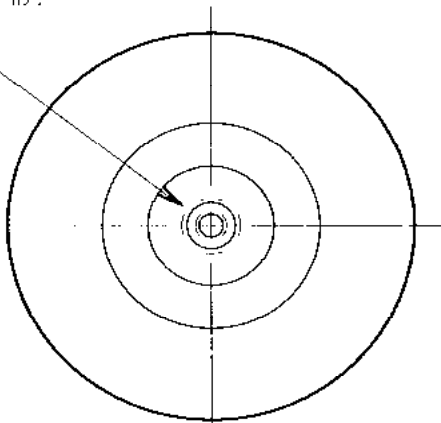

BOTTOM VIEW

ASSEMBLY NUMBER	FLASTOMER	AIR FITTING	BUMPER INCLUDED
1S4-007	WINGPRENE®	1/8" 27 NPT COMBO STUD	NO

SPRING FEATURES:

- LOAD RANGE (ISOLATOR).....160-850 lb
- DESIGN HEIGHT RANGE (SOLATOR).....3.8-4.4 in
- USABLE STROKE (ACTUATOR).....4.9 in
- ASSEMBLY WEIGHT.....1.9 lb
- DIECAST END COMPONENTS

OTHER OPTIONS:

- COMPOSITE END COMPONENTS
- INTEGRAL QUICK CONNECT FITTINGS
- SMOOTH MOUNTING STUDS FOR USE WITH STAR CLIPS (SPEEDS ASSEMBLY)
- AIR FITTING IN TOP

RECOMMENDED MAX. TORQUE VALUES

3/8"-16 UNC BLIND TAP	3/4"-16 UNF COMBO STUD	1/8" 27 UNC AIR FITTING
360 in-lb 30 ft-lb	360 in-lb 30 ft-lb	180 in-lb 15 ft-lb

NOTE: SEE GUIDELINES FOR PROPER APPLICATION OF THIS PRODUCT

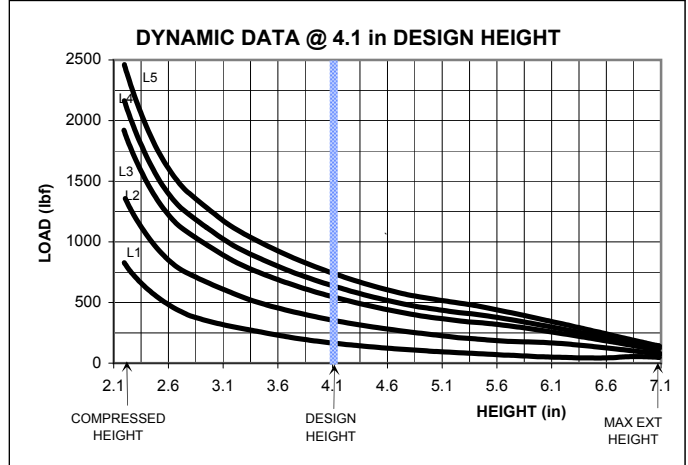
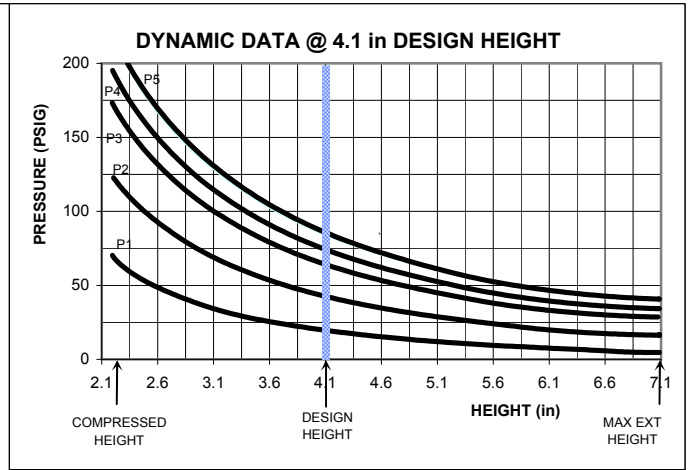
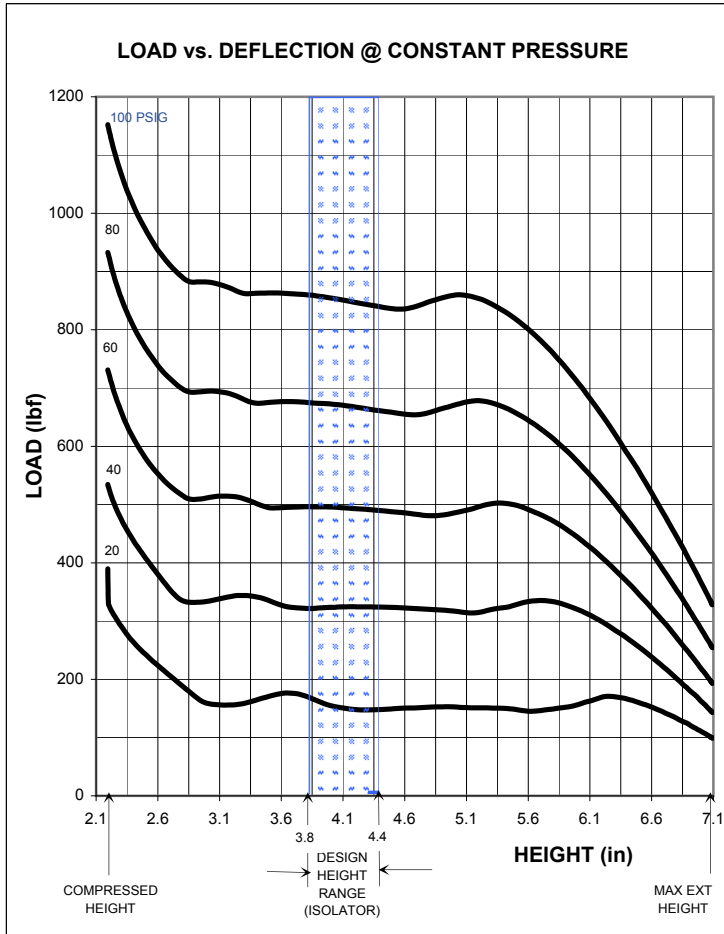

****NOTE: MAXIMUM INFLATION PRESSURE IS 100 PSIG. MAXIMUM JOUNCE PRESSURE IS 200 PSIG. IF YOUR APPLICATION WILL EXCEED THESE LIMITS, CONSULT A GOODYEAR ENGINEERED PRODUCTS AIR SPRINGS REPRESENTATIVE FOR APPLICATION ASSISTANCE.**

CONSTANT PRESSURE CHARACTERISTICS

Assembly Height (in)	Meniscus Height "M" Dim. @ 100 PSIG	Volume @ 100 PSIG (in ³)	Nominal Force (lb)				
			@ 20 PSIG	@ 40 PSIG	@ 60 PSIG	@ 80 PSIG	@ 100 PSIG
7.1	1.5	60	80	130	180	240	310
6.5	1.5	55	160	250	340	460	540
6.0	1.4	50	170	320	440	580	700
5.5	1.3	46	160	320	500	660	800
5.0	1.2	42	160	320	500	680	850
4.4	0.7	37	160	340	500	680	850
4.1	0.5	34	160	340	500	680	850
3.8	0.4	31	160	340	500	680	850
3.0	0.0	24	160	340	520	700	850
2.2	0.0	16	340	520	700	900	1100

DYNAMIC CHARACTERISTICS

Design Height (in)	Load (lb)	Pressure (PSIG)	Spring Rate (lb/in)	Natural Frequency	
				cpm	Hz
4.4	160	23	100	134	2.23
	350	47	175	124	2.07
	525	70	240	118	1.97
	625	79	265	116	1.93
4.1	725	90	285	112	1.87
	160	24	105	136	2.27
	350	46	185	127	2.12
	525	69	255	122	2.03
3.8	625	79	290	121	2.02
	725	91	330	120	2.00
	160	23	125	149	2.48
	350	46	195	131	2.18
3.8	525	67	275	128	2.13
	625	78	310	126	2.10
	725	90	355	125	2.08

The GOODYEAR (and Winged Foot Design) trademark is used by Veyance Technologies, Inc. under license from The Goodyear Tire & Rubber Company. Goodyear Engineered Products are manufactured and sourced exclusively by Veyance Technologies, Inc. or its affiliates. The following trademarks are licensed to Veyance Technologies, Inc. by The Goodyear Tire & Rubber Company, including Compass, Eagle Pd, Flexten, Gatorback and GY Metric. ©2008 Veyance Technologies, Inc. All Rights Reserved.



1S4-008

3/4" -16 UNF-2A
x 5/8" M.N.TH.D.
COMBO STUD
1/8" -27 NPTF
AIR FITTING
(INSIDE)

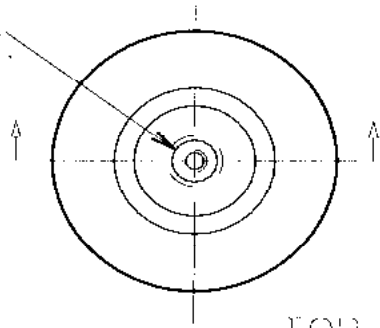

TOP VIEW

TOP AND BOTTOM
SURFACE TO BE
FULLY SUPPORTED
TO 4.1" DIA.

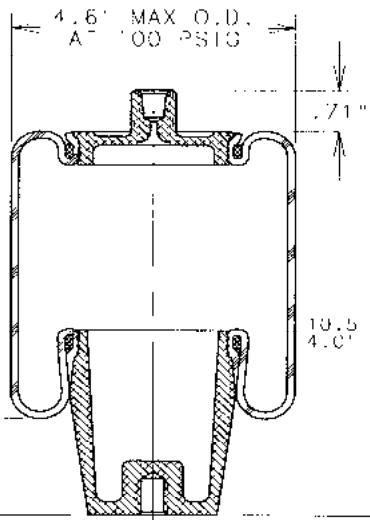

SIDE VIEW

NOTE: 10 PSIG MIN.
PRESSURE REQUIRED
TO OPERATE PROPERLY

1/2" -13 UNC-2B
x 5/8" DEEP

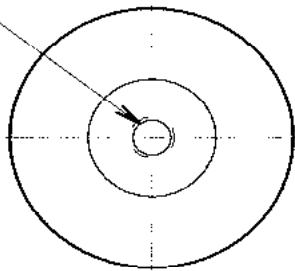

BOTTOM VIEW

ASSEMBLY NUMBER	FLASOMER	AIR FITTING	BUMPER INCLUDED
1S4-008	WINGPRENE [®]	1/8" -27 NPTF COMBO STUD	NO

SPRING FEATURES:

- LOAD RANGE (ISOLATOR).....150-800 lb
- DESIGN HEIGHT RANGE (ISOLATOR).....6.5-7.5 in
- USEABLE STROKE (ACTUATOR).....6.5 in
- ASSEMBLY WEIGHT.....2.6 lb
- DIECAST END COMPONENTS

OTHER OPTIONS:

- COMPOSITE END COMPONENTS
- INTEGRAL QUICK CONNECT FITTINGS
- SMOOTH MOUNTING STUDS FOR USE WITH STAR CLIPS (SPEEDS ASSEMBLY)
- AIR FITTING IN PISTON
- INTERNAL RUBBER BUMPER

RECOMMENDED MAX. TORQUE VALUES

1/2" -13 UNC BLIND TAP	3/4" -16 UNC COMBO STUD	1/8" -27 UNC AIR FITTING
360 in-lb 30 ft-lb	360 in-lb 30 ft-lb	180 in-lb 15 ft-lb

NOTE: SEE GUIDELINES FOR PROPER APPLICATION OF THIS PRODUCT

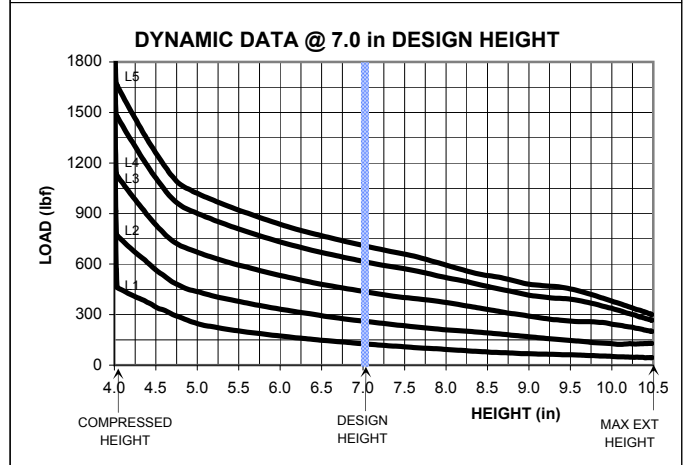
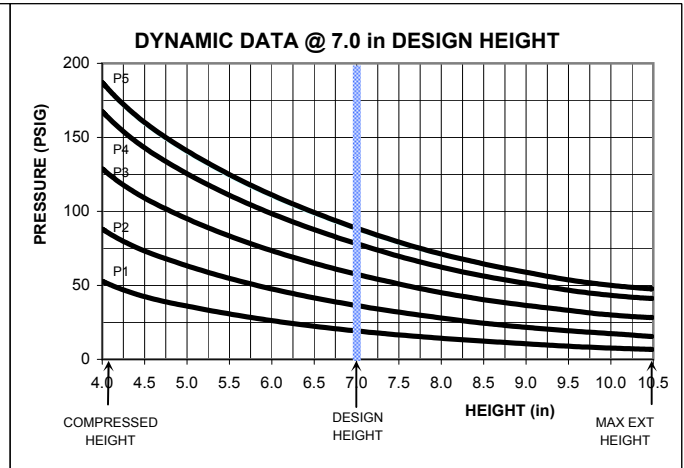
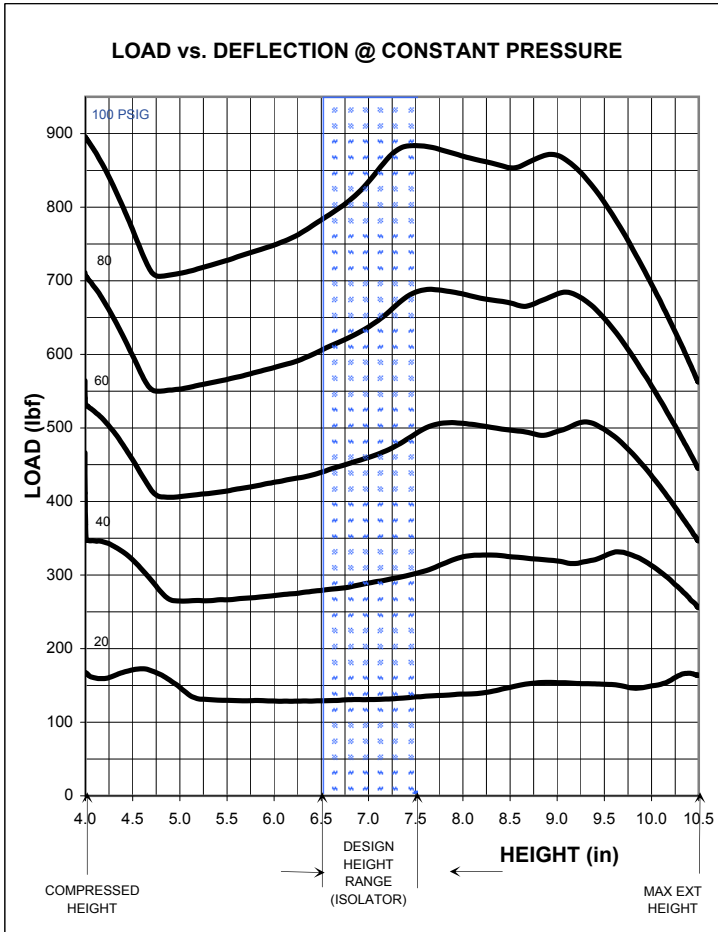

****NOTE: MAXIMUM INFLATION PRESSURE IS 100 PSIG. MAXIMUM JOUNCE PRESSURE IS 200 PSIG. IF YOUR APPLICATION WILL EXCEED THESE LIMITS, CONSULT A GOODYEAR ENGINEERED PRODUCTS AIR SPRINGS REPRESENTATIVE FOR APPLICATION ASSISTANCE.**

CONSTANT PRESSURE CHARACTERISTICS

Assembly Height (in)	Meniscus Height "M" Dim. @ 100 PSIG	Volume @ 100 PSIG (in ³)	Nominal Force (lb)				
			@ 20 PSIG	@ 40 PSIG	@ 60 PSIG	@ 80 PSIG	@ 100 PSIG
10.5	3.3	89	140	250	340	420	540
9.0	3.1	76	160	320	520	700	850
8.0	2.4	67	150	340	520	700	850
7.5	2.1	62	150	320	520	700	900
7.0	1.8	58	140	300	480	680	900
6.5	1.4	52	140	280	460	640	800
6.0	0.9	47	130	280	440	600	750
5.0	0.2	35	150	260	420	560	700
4.5	0.1	30	180	320	460	600	750
4.0	0.0	24	170	340	520	700	850

DYNAMIC CHARACTERISTICS

Design Height (in)	Load (lb)	Pressure (PSIG)	Spring Rate (lb/in)	Natural Frequency	
				cpm	Hz
7.5	125	19	40	99	1.65
	250	36	55	80	1.33
	425	57	105	85	1.42
	625	79	160	89	1.48
7.0	700	90	190	91	1.52
	125	21	40	97	1.62
	250	39	60	82	1.37
	425	60	70	71	1.18
6.5	625	82	95	69	1.15
	700	92	110	70	1.17
	125	21	45	103	1.72
	250	39	70	90	1.50
6.0	425	62	90	80	1.33
	625	87	105	72	1.20
	700	99	105	67	1.12

The GOODYEAR (and Winged Foot Design) trademark is used by Veyance Technologies, Inc. under license from The Goodyear Tire & Rubber Company. Goodyear Engineered Products are manufactured and sourced exclusively by Veyance Technologies, Inc. or its affiliates. The following trademarks are licensed to Veyance Technologies, Inc. by The Goodyear Tire & Rubber Company, including Compass, Eagle Pd, Flexten, Gatorback and GY Metric. ©2008 Veyance Technologies, Inc. All Rights Reserved.



1S5-005

5/4 -16 UNF-2A
x 5/8" MIN. THD.
COMBO STUD
1/8 -27 NPTF
AIR FITTING
(INSIDE)

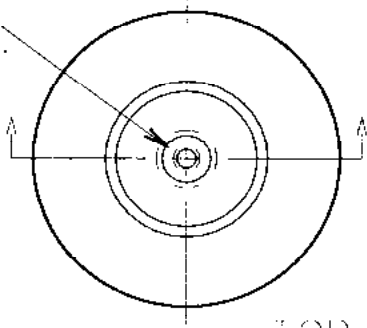

TOP VIEW

TOP AND BOTTOM
SURFACE TO BE
FULLY SUPPORTED
TO 4.1" DIA.

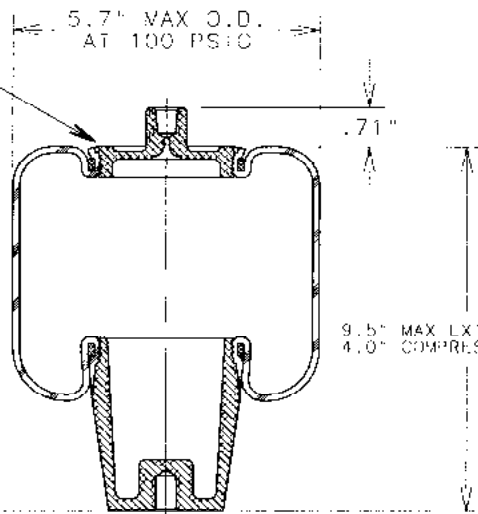

NOTE: 10 PSIG MIN.
PRESSURE REQUIRED
TO OPERATE PROPERLY

9.5" MAX EXTENDED HI.
4.0" COMPRESSED HI.

SIDE VIEW

1/2"-13 UNC-2B
x 5/8" DEEP

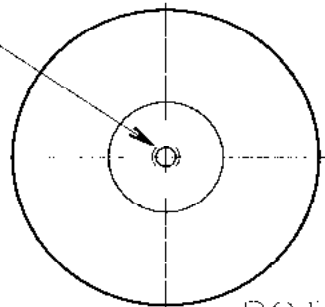

BOTTOM VIEW

ASSEMBLY NUMBER	ELASTOMER	AIR FITTING	BUMPER INCLUDED
1S5-005	WINGPRENE®	1/8"-27 NPTF COMBO STUD	NO

CONTACT A GOODYEAR ENGINEERED PRODUCTS AIR SPRINGS REPRESENTATIVE BEFORE USING AS AN ACTUATOR

SPRING FEATURES:

- LOAD RANGE (ISOLATOR).....170-1100 lb
- DEFLECTION RANGE (ISOLATOR).....6.2-7.2 in
- USEABLE STROKE (ACTUATOR).....3.5 in
- ASSEMBLY WEIGHT.....2.5 lb
- D LCAST END COMPONENTS

OTHER OPTIONS:

- COMPOSITE END COMPONENTS
- INTEGRAL QUICK CONNECT FITTINGS
- SMOOTH MOUNTING STUDS FOR USE WITH STAR CLIPS (SPELDS ASSEMBLY)
- AIR FITTING IN PISTON
- INTERNAL RUBBER BUMPER

RECOMMENDED MAX. TORQUE VALUES

1/2"-13 UNC BLEND TAP	3/4"-16 UNF COMBO STUD	1/8"-27 UNC AIR FITTING
360 in-lb 30 ft-lb	360 in-lb 30 ft-lb	180 in-lb 15 ft-lb

NOTE: SEE GUIDELINES FOR PROPER APPLICATION OF THIS PRODUCT

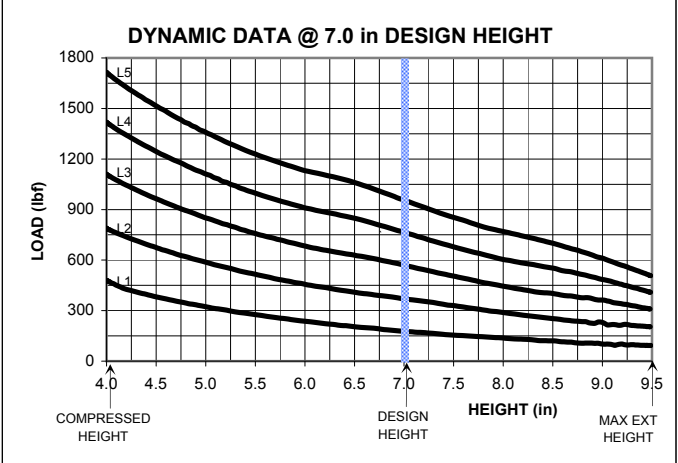
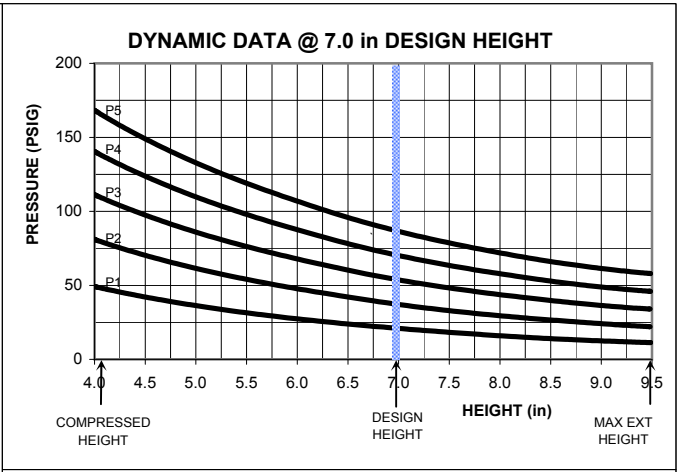
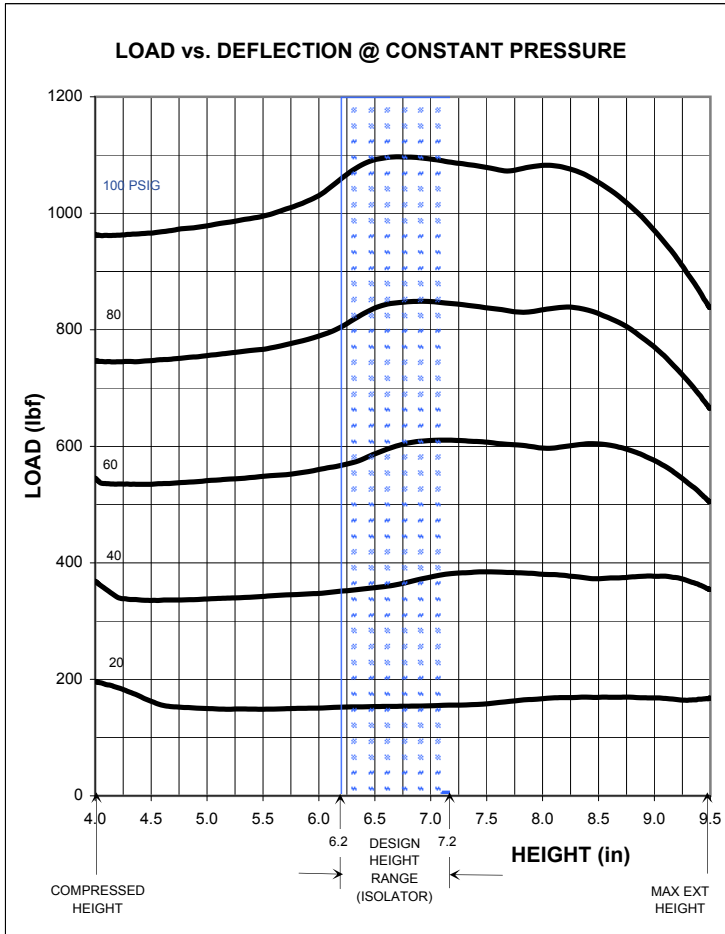

****NOTE: MAXIMUM INFLATION PRESSURE IS 100 PSIG. MAXIMUM JOUNCE PRESSURE IS 200 PSIG. IF YOUR APPLICATION WILL EXCEED THESE LIMITS, CONSULT A GOODYEAR ENGINEERED PRODUCTS AIR SPRINGS REPRESENTATIVE FOR APPLICATION ASSISTANCE.**

CONSTANT PRESSURE CHARACTERISTICS

Assembly Height (in)	Meniscus Height "M" Dim. @ 100 PSIG	Volume @ 100 PSIG (in ³)	Nominal Force (lb)				
			@ 20 PSIG	@ 40 PSIG	@ 60 PSIG	@ 80 PSIG	@ 100 PSIG
9.5	3.3	109	160	340	500	660	800
8.5	3.1	104	180	400	620	800	1050
8.0	2.8	93	180	400	620	850	1100
7.2	2.3	84	170	400	620	850	1100
7.0	2.1	82	170	400	620	850	1100
6.2	1.7	72	160	360	620	850	1100
5.5	1.1	64	160	360	560	800	1000
5.0	0.8	57	160	340	560	750	1000
4.5	0.4	51	170	340	560	750	950
4.0	0.1	45	190	360	540	750	950

DYNAMIC CHARACTERISTICS

Design Height (in)	Load (lb)	Pressure (PSIG)	Spring Rate (lb/in)	Natural Frequency	
				cpm	Hz
7.2	200	21	50	95	1.58
	400	39	100	94	1.57
	550	57	140	91	1.52
	750	73	180	89	1.48
7.0	200	21	50	95	1.58
	400	38	105	95	1.58
	550	55	150	94	1.57
	750	72	190	91	1.52
6.2	200	23	55	99	1.65
	400	40	80	85	1.42
	550	56	105	79	1.32
	750	73	135	78	1.30
5.5	200	23	55	99	1.65
	400	40	80	85	1.42
	550	56	105	79	1.32
	750	73	135	78	1.30

The GOODYEAR (and Winged Foot Design) trademark is used by Veyance Technologies, Inc. under license from The Goodyear Tire & Rubber Company. Goodyear Engineered Products are manufactured and sourced exclusively by Veyance Technologies, Inc. or its affiliates. The following trademarks are licensed to Veyance Technologies, Inc. by The Goodyear Tire & Rubber Company, including Compass, Eagle Pd, Flexten, Gatorback and GY Metric. ©2008 Veyance Technologies, Inc. All Rights Reserved.



1S5-006

3/4" -16 UNF -2A
x 5/8" M.N. THD.
COMBO STUD
1/8" -27 NPTF
AIR FITTING
(INSIDE)

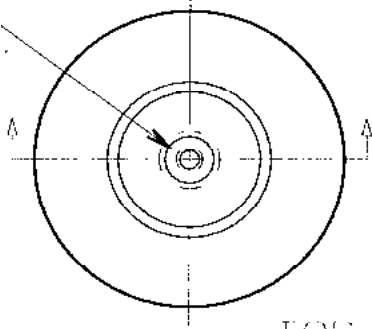

TOP VIEW

TOP AND BOTTOM
SURFACE TO BE
FULLY SUPPORTED
TO 5.1" DIA.

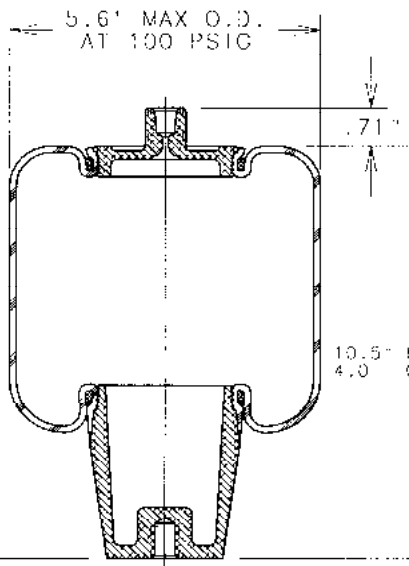

SIDE VIEW

NOTE: 10 PSIG MIN.
PRESSURE REQUIRED
TO OPERATE PROPERLY

1/2" -13 UNC -2B
x 3/8" DEEP

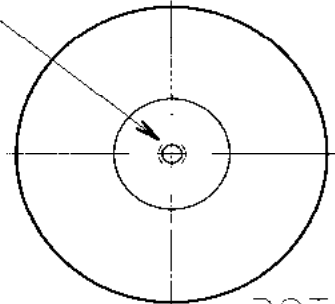

BOTTOM VIEW

ASSEMBLY NUMBER	ELASTOMER	AIR FITTING	BUMPER INCLUDED
1S5-006	WINGPRENE®	1/8" -27 NPTF COMBO STUD	NO

CONTACT A GOODYEAR ENGINEERED PRODUCTS AIR SPRINGS REPRESENTATIVE BEFORE USING AS AN ACTUATOR

SPRING FEATURES:

- LOAD RANGE (ISOLATOR).....190-1150 lb
- DESIGN HEIGHT RANGE (ISOLATOR).....7.0-9.0 in
- USABLE STROKE (ACTUATOR).....6.5 in
- ASSEMBLY WEIGHT.....2.6 lb
- DIECAST END COMPONENTS

OTHER OPTIONS:

- COMPOSITE END COMPONENTS
- INTEGRAL QUICK CONNECT FITTINGS
- SMOOTH MOUNTING STUDS FOR USE WITH STAR GLIPS (SPEEDS ASSEMBLY)
- AIR FITTING ON PISTON
- INTERNAL RUBBER BUMPER

RECOMMENDED MAX. TORQUE VALUES

1/2"-13 UNC BLIND TAP	3/4"-16 UNF COMBO STUD	1/8"-27 UNC AIR FITTING
360 in-lb 30 ft-lb	360 in-lb 30 ft-lb	180 in-lb 15 ft-lb

NOTE: SEE GUIDELINES FOR PROPER APPLICATION OF THIS PRODUCT

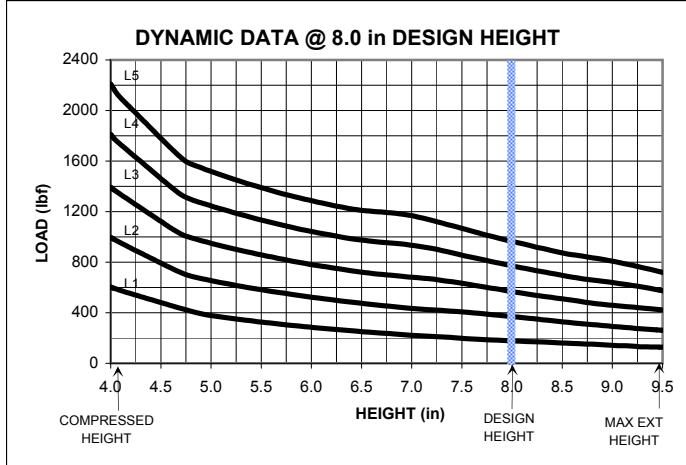
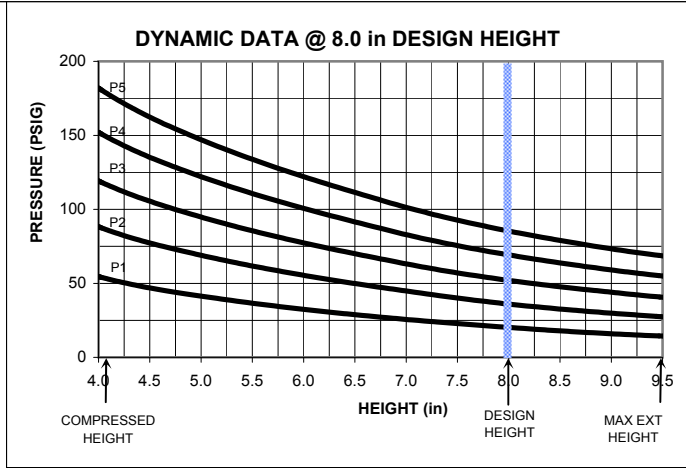
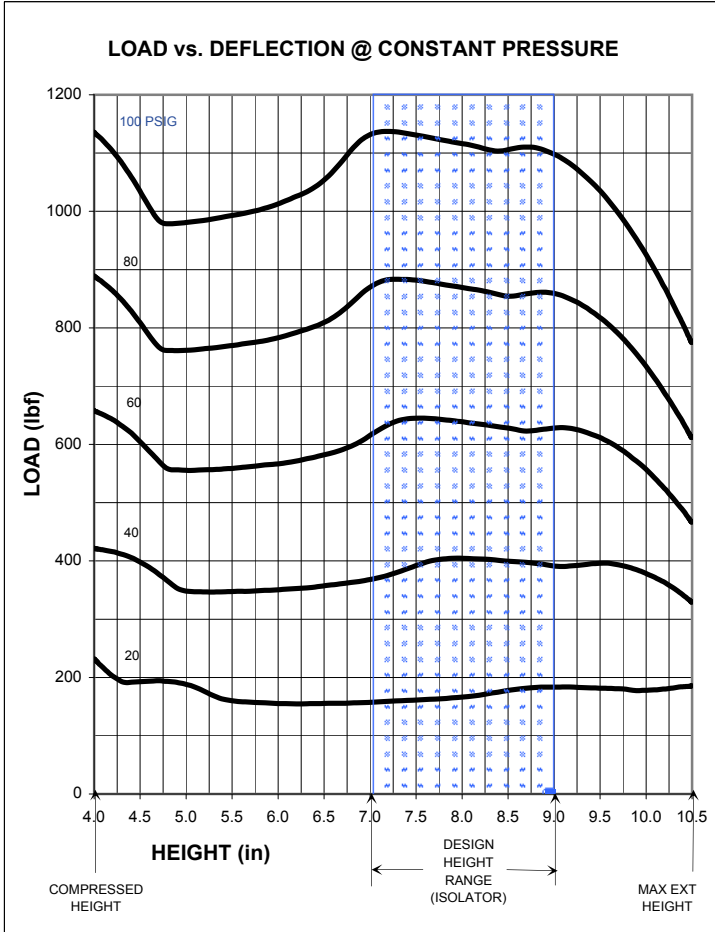

****NOTE: MAXIMUM INFLATION PRESSURE IS 100 PSIG. MAXIMUM JOUNCE PRESSURE IS 200 PSIG. IF YOUR APPLICATION WILL EXCEED THESE LIMITS, CONSULT A GOODYEAR ENGINEERED PRODUCTS AIR SPRINGS REPRESENTATIVE FOR APPLICATION ASSISTANCE.**

CONSTANT PRESSURE CHARACTERISTICS

Assembly Height (in)	Meniscus Height "M" Dim. @ 100 PSIG	Volume @ 100 PSIG (in ³)	Nominal Force (lb)				
			@ 20 PSIG	@ 40 PSIG	@ 60 PSIG	@ 80 PSIG	@ 100 PSIG
10.5	3.3	133	180	320	460	600	750
10.0	3.1	131	190	380	550	750	900
9.0	2.9	118	190	400	640	850	1100
8.5	2.7	111	190	400	640	850	1100
8.0	2.4	106	180	420	640	850	1100
7.5	2.1	100	170	420	660	900	1150
7.0	1.8	95	170	400	660	900	1150
6.0	0.9	80	160	360	580	800	1050
5.0	0.5	70	190	360	560	750	1000
4.0	0.0	58	230	420	660	850	1100

DYNAMIC CHARACTERISTICS

Design Height (in)	Load (lb)	Pressure (PSIG)	Spring Rate (lb/in)	Natural Frequency	
				cpm	Hz
9.0	200	21	50	92	1.53
	400	38	80	85	1.42
	550	55	120	84	1.40
	750	73	175	88	1.47
8.0	200	21	40	85	1.42
	400	38	95	91	1.52
	550	56	130	87	1.45
	750	73	165	85	1.42
7.0	200	22	50	92	1.53
	400	39	75	81	1.35
	550	54	120	83	1.38
	750	71	165	85	1.42
9.0	950	89	195	83	1.38
	200	22	50	92	1.53
	400	39	75	81	1.35
	550	54	120	83	1.38
7.0	750	71	165	85	1.42
	950	88	205	85	1.42

The GOODYEAR (and Winged Foot Design) trademark is used by Veyance Technologies, Inc. under license from The Goodyear Tire & Rubber Company. Goodyear Engineered Products are manufactured and sourced exclusively by Veyance Technologies, Inc. or its affiliates. The following trademarks are licensed to Veyance Technologies, Inc. by The Goodyear Tire & Rubber Company, including Compass, Eagle Pd, Flexten, Gatorback and GY Metric. ©2008 Veyance Technologies, Inc. All Rights Reserved.



1S5-010

3/8" - 16 UNC 2B
x 1/2" DEEP

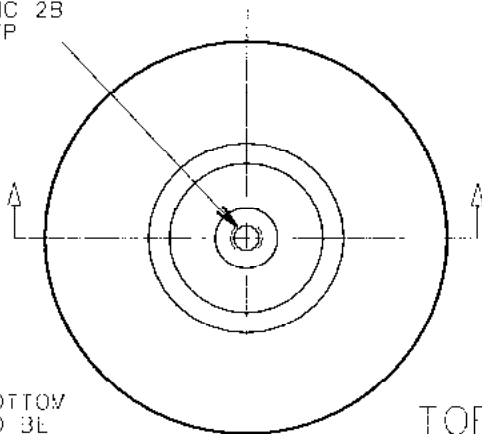

TOP VIEW

TOP AND BOTTOM SURFACE TO BE FULLY SUPPORTED TO 5.1" D.A.

5.6" MAX O.D. AT 100 PSIG

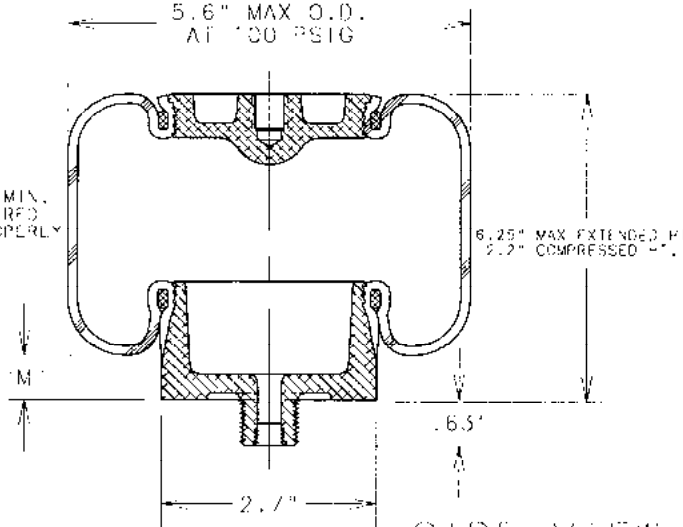

SIDE VIEW

NOTE: 10 PSIG MIN. PRESSURE REQUIRED TO OPERATE PROPERLY

3/4" - 16 UNF - 2A
x 9/16" MIN. THD.
COMBO STUD
1/8" - 27 NPTF
AIR FITTING
(INSIDE)

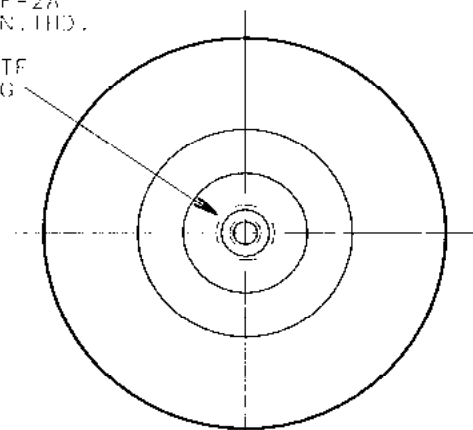

BOTTOM VIEW

ASSEMBLY NUMBER	FLASTOMER	AIR FITTING	BUMPER INCLUDED
1S5-010	WINGPRENE®	1/8"-27 NPTF COMBO STUD	NO

CONTACT A GOODYEAR ENGINEERED PRODUCTS AIR SPRINGS REPRESENTATIVE BEFORE USING AS AN ACTUATOR

SPRING FEATURES:

- LOAD RANGE (ISOLATOR).....180-1100 lb
- DESIGN HEIGHT RANGE (ISOLATOR).....3.8-4.3 in
- USFAR F STROKE (ACTUATOR).....4.0 in
- ASSEMBLY WEIGHT.....1.9 lb
- DILCAST END COMPONENTS

OTHER OPTIONS:

- COMPOSITE END COMPONENTS
- INTEGRAL QUICK CONNECT FITTINGS
- SMOOTH MOUNTING STUDS FOR USE WITH STAR CLIPS (SPEEDIS ASSEMBLY)
- AIR FITTING IN TOP

RECOMMENDED MAX. TORQUE VALUES

3/8" - 16 UNC BEIND TAP	3/4" - 16 UNF COMBO STUD	1/8" - 27 UNC AIR FITTING
350 in-lb 30 ft-lb	350 in-lb 30 ft-lb	180 in-lb 15 ft-lb

NOTE: SEE GUIDELINES FOR PROPER APPLICATION OF THIS PRODUCT

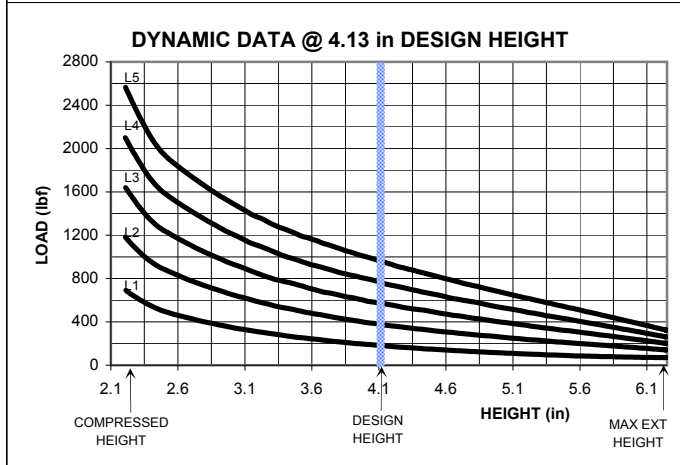
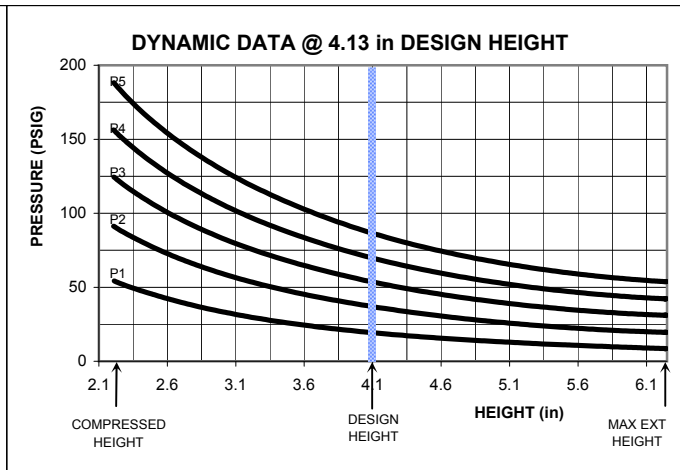
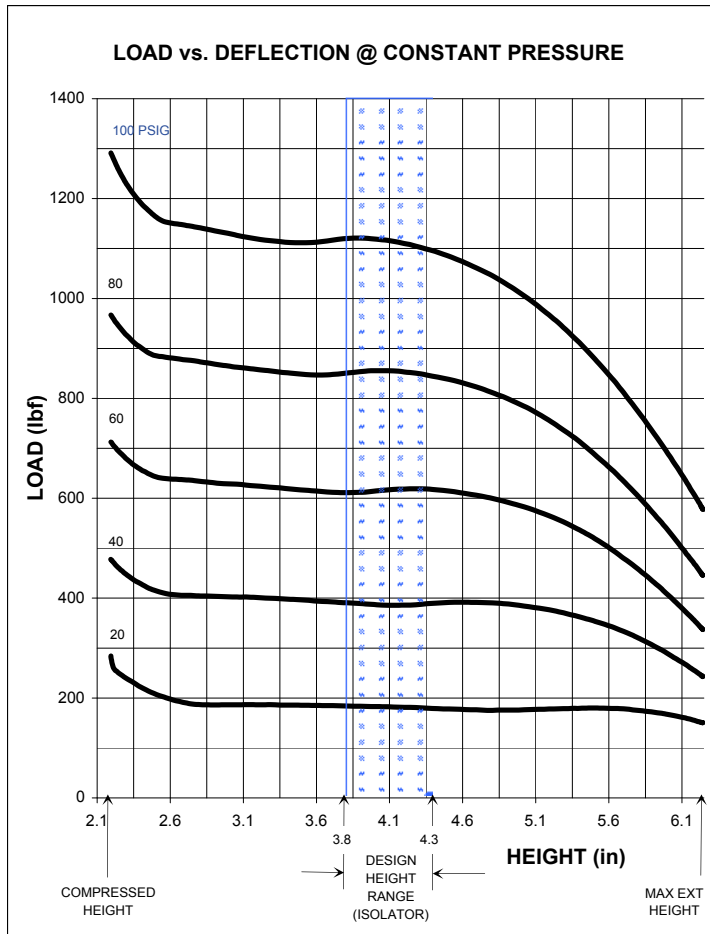

****NOTE: MAXIMUM INFLATION PRESSURE IS 100 PSIG. MAXIMUM JOUNCE PRESSURE IS 200 PSIG. IF YOUR APPLICATION WILL EXCEED THESE LIMITS, CONSULT A GOODYEAR ENGINEERED PRODUCTS AIR SPRINGS REPRESENTATIVE FOR APPLICATION ASSISTANCE.**

CONSTANT PRESSURE CHARACTERISTICS

Assembly Height (in)	Meniscus Height "M" Dim. @ 100 PSIG	Volume @ 100 PSIG (in ³)	Nominal Force (lb)				
			@ 20 PSIG	@ 40 PSIG	@ 60 PSIG	@ 80 PSIG	@ 100 PSIG
6.25	1.5	70	140	240	320	440	560
5.75	1.4	66	180	320	460	620	800
5.0	1.2	58	180	380	580	800	1000
4.3	1.1	51	180	400	620	850	1100
4.13	1.0	48	180	400	620	850	1100
3.8	0.8	45	190	400	620	850	1100
3.5	0.7	42	190	400	620	850	1100
3.0	0.3	36	190	400	640	850	1100
2.5	0.1	31	210	420	660	900	1150
2.2	0.0	28	250	460	700	950	1250

DYNAMIC CHARACTERISTICS

Design Height (in)	Load (lb)	Pressure (PSIG)	Spring Rate (lb/in)	Natural Frequency	
				cpm	Hz
4.3	200	21	100	131	2.18
	400	38	165	120	2.00
	600	55	240	119	1.98
	800	73	315	118	1.97
4.13	950	90	385	117	1.95
	200	21	105	134	2.23
	400	38	170	122	2.03
	600	55	240	119	1.98
3.8	800	72	310	117	1.95
	950	88	380	116	1.93
	200	21	100	134	2.23
	400	39	170	123	2.05
3.5	600	56	235	118	1.97
	800	74	305	116	1.93
	950	88	360	113	1.88

The GOODYEAR (and Winged Foot Design) trademark is used by Veyance Technologies, Inc. under license from The Goodyear Tire & Rubber Company. Goodyear Engineered Products are manufactured and sourced exclusively by Veyance Technologies, Inc. or its affiliates. The following trademarks are licensed to Veyance Technologies, Inc. by The Goodyear Tire & Rubber Company, including Compass, Eagle Pd, Flexten, Gatorback and GY Metric. ©2008 Veyance Technologies, Inc. All Rights Reserved.



1S6-023

M20-2.5-6g METRIC
x 10 mm MIN. THD.
COMBO STUD
1/8"-27 NPTF
AIR FITTING
(INSIDE)

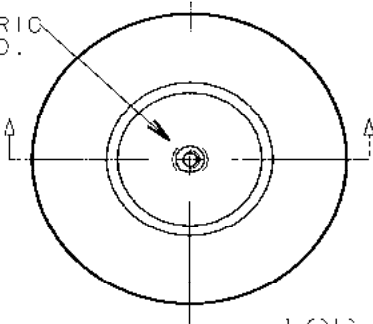

TOP VIEW

TOP AND BOTTOM
SURFACE TO BE
FULLY SUPPORTED
TO 6.3" DIA.

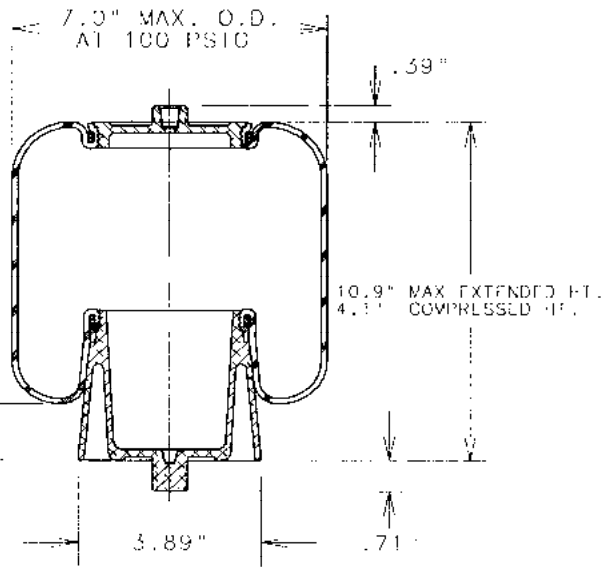

SIDE VIEW

NOTE: 10 PSIG MIN.
PRESSURE REQUIRED
TO OPERATE PROPERLY

M20-2.5-6g METRIC
x 15 mm MIN. THD.

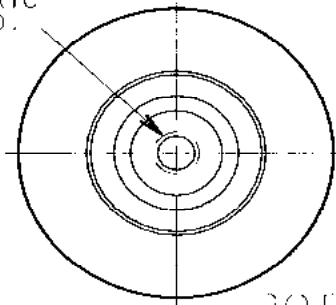

BOTTOM VIEW

ASSEMBLY NUMBER	ELASTOMER	AIR FITTING	BUMPER INCLUDED
1S6-023	WINGPRENE®	1/8"-27 NPTF COMBO STUD	NO

SPRING FEATURES:

- LOAD RANGE (ISOLATOR).....260-1800 lb
- DESIGN HEIGHT RANGE (ISOLATOR).....7.0-8.6 in
- USEABLE STROKE (ACTUATOR).....5.8 in
- ASSEMBLY WEIGHT.....2.9 lb
- DIECAST END COMPONENTS

OTHER OPTIONS:

- COMPOSITE END COMPONENTS
- SMOOTH MOUNTING STUDS FOR USE WITH STAR CLIPS (SPEEDS ASSEMBLY)
- AIR FITTING IN PISTON

RECOMMENDED MAX. TORQUE VALUES

M20-2.5-6g METRIC STUD	M20-2.5-6g METRIC COMBO STUD	1/8"-27 UNC AIR FITTING
360 in-lb 30 ft-lb	360 in-lb 30 ft-lb	180 in-lb 15 ft-lb

NOTE: SEE GUIDELINES FOR PROPER APPLICATION OF THIS PRODUCT

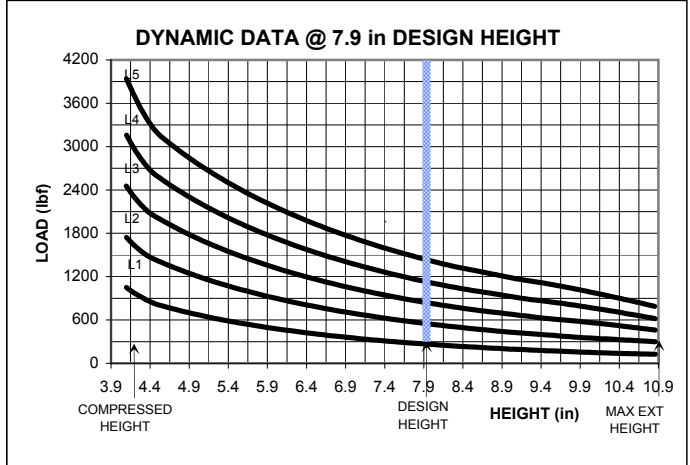
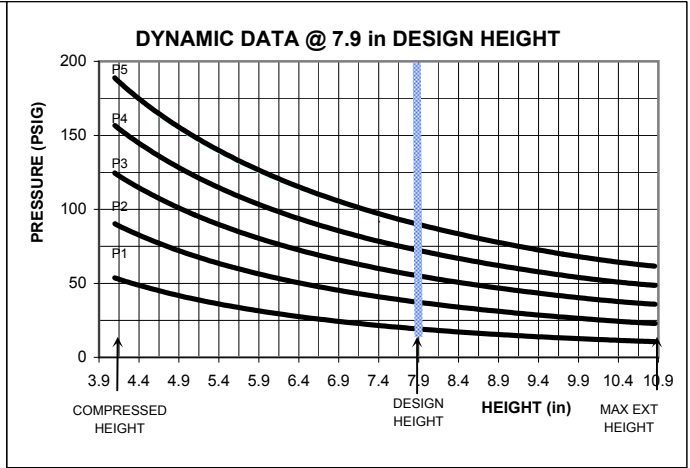
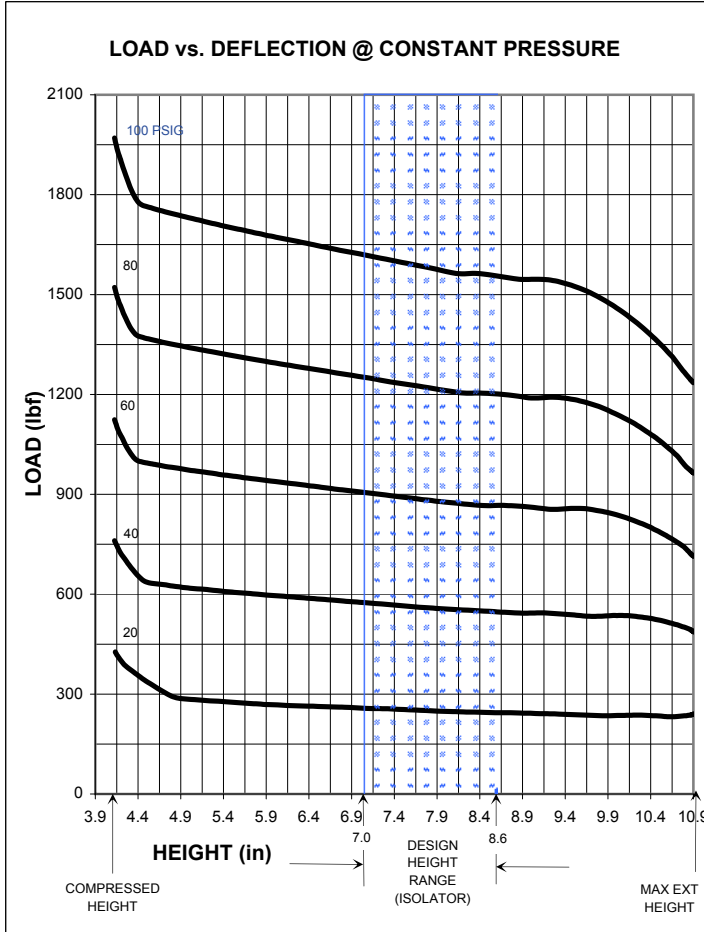

****NOTE: MAXIMUM INFLATION PRESSURE IS 100 PSIG. MAXIMUM JOUNCE PRESSURE IS 200 PSIG. IF YOUR APPLICATION WILL EXCEED THESE LIMITS, CONSULT A GOODYEAR ENGINEERED PRODUCTS AIR SPRINGS REPRESENTATIVE FOR APPLICATION ASSISTANCE.**

CONSTANT PRESSURE CHARACTERISTICS

Assembly Height (in)	Meniscus Height "M" Dim. @ 100 PSIG	Volume @ 100 PSIG (in ³)	Nominal Force (lb)				
			@ 20 PSIG	@ 40 PSIG	@ 60 PSIG	@ 80 PSIG	@ 100 PSIG
10.9	3.3	205	240	480	700	950	1200
10.0	3.1	191	260	560	850	1150	1450
9.5	2.9	182	260	560	850	1200	1500
9.0	2.7	173	260	580	900	1250	1600
8.6	2.5	167	260	580	900	1250	1600
7.9	2.0	154	260	580	900	1250	1600
7.0	1.5	140	280	600	950	1300	1600
6.0	0.9	123	280	620	950	1300	1700
5.0	0.3	107	300	640	1000	1350	1700
4.1	0.0	93	420	750	1100	1500	2000

DYNAMIC CHARACTERISTICS

Design Height (in)	Load (lb)	Pressure (PSIG)	Spring Rate (lb/in)	Natural Frequency	
				cpm	Hz
8.6	300	21	75	95	1.58
	600	40	120	83	1.38
	850	57	165	81	1.35
	1150	74	205	78	1.30
7.9	1450	92	250	77	1.28
	300	20	85	102	1.70
	600	39	140	91	1.52
	850	57	190	87	1.45
7.0	1150	75	230	82	1.37
	1450	92	275	80	1.33
	300	20	90	104	1.73
	600	39	155	96	1.60
7.0	850	56	220	92	1.53
	1250	73	265	88	1.47
	1450	90	320	87	1.45

The GOODYEAR (and Winged Foot Design) trademark is used by Veyance Technologies, Inc. under license from The Goodyear Tire & Rubber Company. Goodyear Engineered Products are manufactured and sourced exclusively by Veyance Technologies, Inc. or its affiliates. The following trademarks are licensed to Veyance Technologies, Inc. by The Goodyear Tire & Rubber Company, including Compass, Eagle Pd, Flexten, Gatorback and GY Metric. ©2008 Veyance Technologies, Inc. All Rights Reserved.