



Garantía de Calidad y Servicio

Empresa Certificada ISO 9001:2008

Catálogo de Partes Complementarias para Muelles

Julio 2013

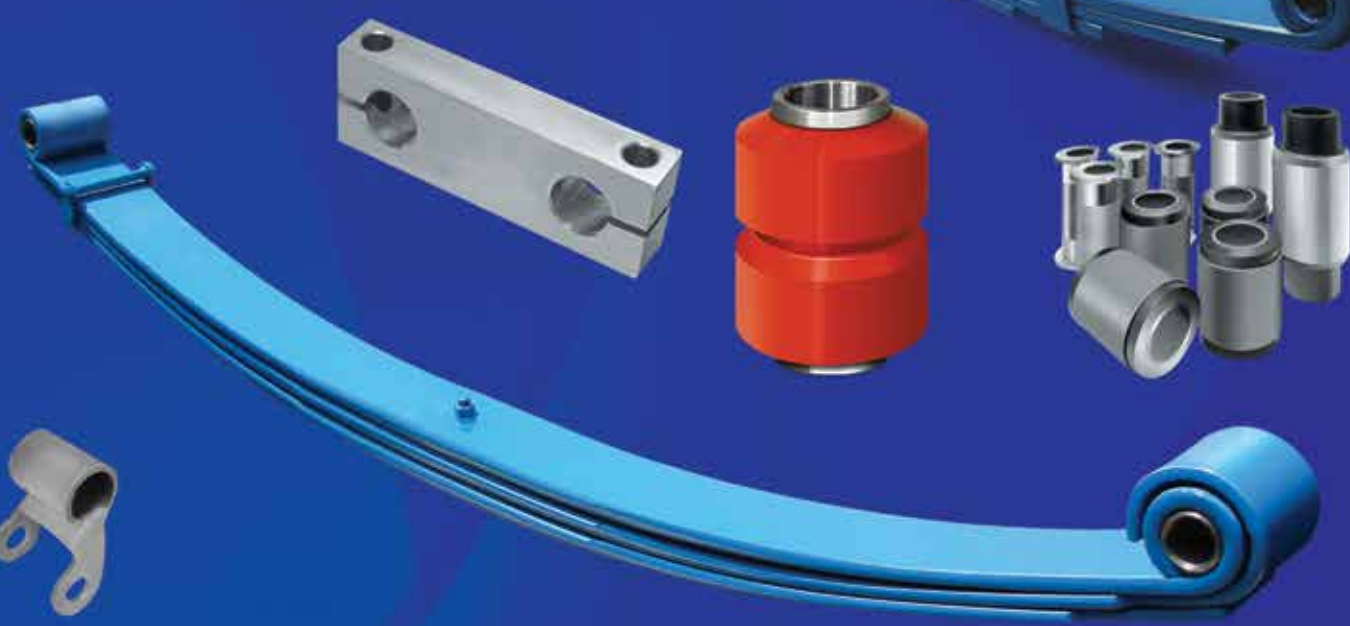
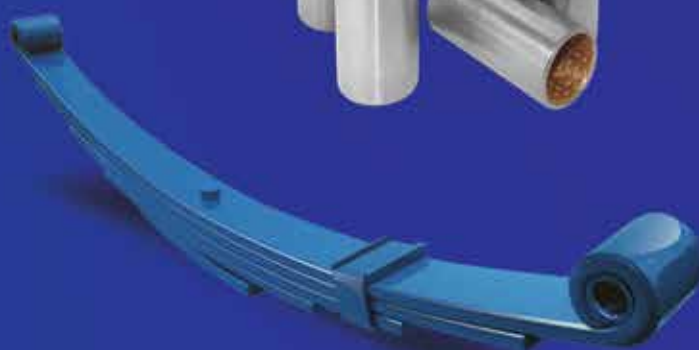

\$ 300.00 M.N.
US \$30.00





† - 1986

Manuel Álvarez Fernández

Álvarez Automotriz

CATÁLOGO DE PARTES COMPLEMENTARIAS DE MUELLES Y SUSPENSION GRUPO MAF.

Empresa fundada por el señor Manuel Álvarez Fernández en 1925, quién comenzó su camino hacia la industria automotriz conduciendo autobuses de pasajeros, posteriormente, se entregó con dedicación y entusiasmo, aunque en pequeña escala, a cambiar y adaptar muelles para camiones.

Pionero en aquella época. Siguió un camino arduo y difícil, pues no contaba con herramientas especializadas.

Abrió su taller de reparación y cambio de muelles en Corregidora 170, en el centro de la ciudad de México, ofrecía a sus clientes puntualidad, precio competitivo y excelente calidad.

El señor Manuel Álvarez Fernández mantuvo la inquietud de servir cada vez mejor a cada uno de sus clientes, lo cual llevó a adquirir maquinaria para la fabricación de muelles.

En grupo MAF hemos seguimos ofreciendo a lo largo de 60 años, nuestra línea de muelles y partes complementarias, atendiendo actualmente los mercados dentro de la Republica Mexicana, Estados Unidos y Latinoamérica.



Garantía en Calidad y Servicio

Índice de contenidos

Índice de contenidos

Chrysler	4-6
Dina	7-16
Dina Navistar	17-45
Navistar Internacional	46-71
Famsa	72-80
Frightliner	81-119
Ford	120-143
Fruehauf	144-165
General Motors	166-183
Hendrickson	184-197
Kenworth	198-218
Mercedes Benz	219-225
Nissan	226-229
Remolques QTR	230-233
Remolques Hutch	234-250
Remolques Reyco	252-255
Volvo	256-265
Apéndice	
Tomillo "U"	267
Bujes de Bronce	268-270
Bujes de Fierro y Hule	271-275
Tuercas	276-278
Tornillos	279-283
Tabla de Conversiones	284
Direcciones de sucursales	285

CHRYSLER

DODGE D600 Modelo 74 - 87 Muelle DD825

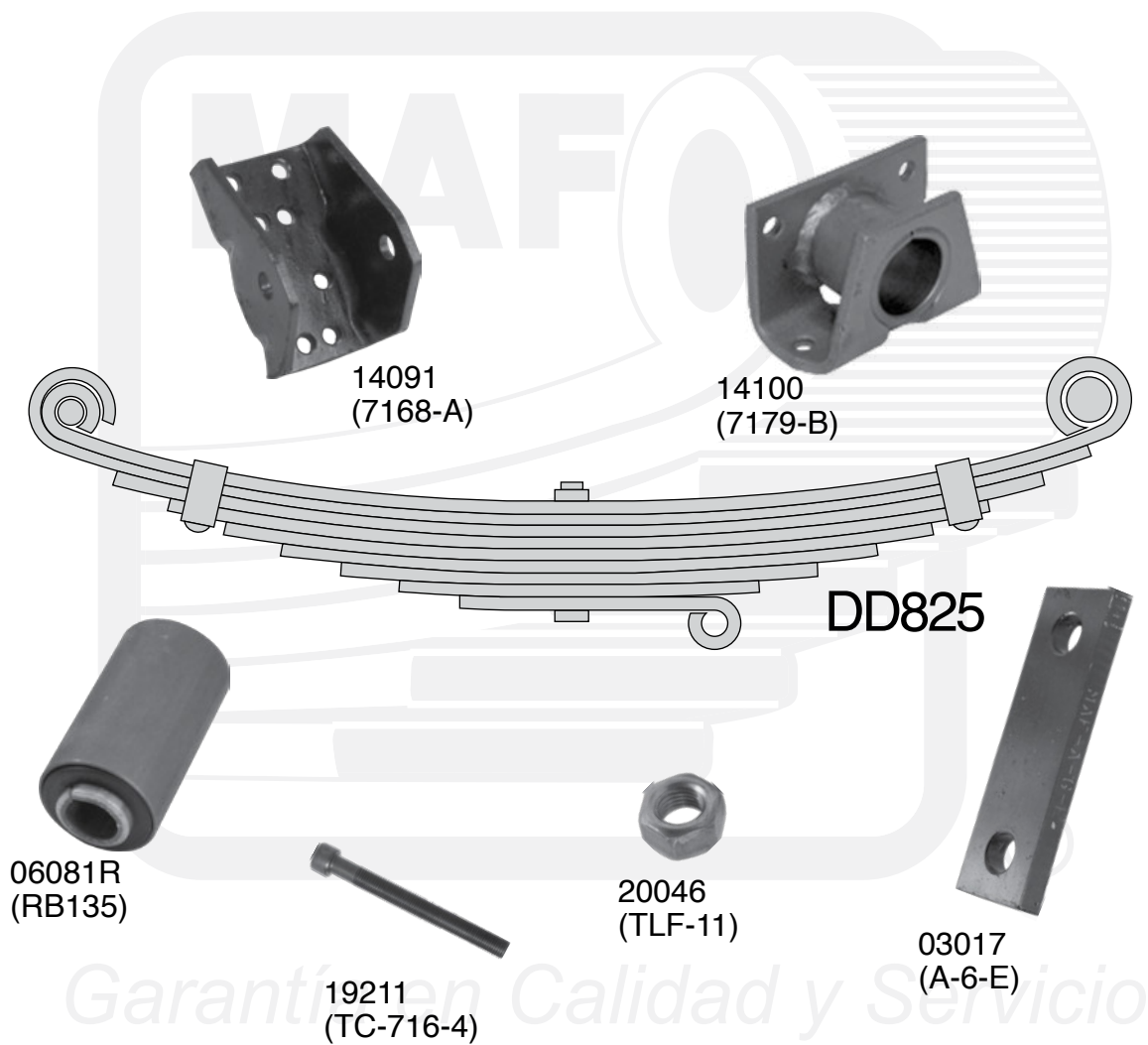

CHRYSLER

DODGE D600

Modelo 74 - 87 Muelle DD825

CÓDIGO	No. MAF	DESCRIPCIÓN	CANTIDAD
14091	7168-A	PERCHA DEL. DEL. # 1	2
14100	7179-B	PERCHA DEL. TRAS. #2	2
19211	TC-716-4	TORNILLO DE CENTRO 7/16" x 4.00"	2
03017	A-6-E	ALBARDÓN D-600 / P-600	4
20046	TLF11	TUERCA UNF. °2 DE 7/16"	2
06081R	RB-135=RB-267	BUJE FIERRO Y HULE RB-135=RB-267	4
DD825	DD-825	MUELLE 8 HOJAS CON BRAKET	2
		HOJA 01 3" x .360" x 26" x 26"	

VER CATÁLOGO DE MUELLES MAF 2011



Suspensión MAF 300

Productos MAF para otras aplicaciones

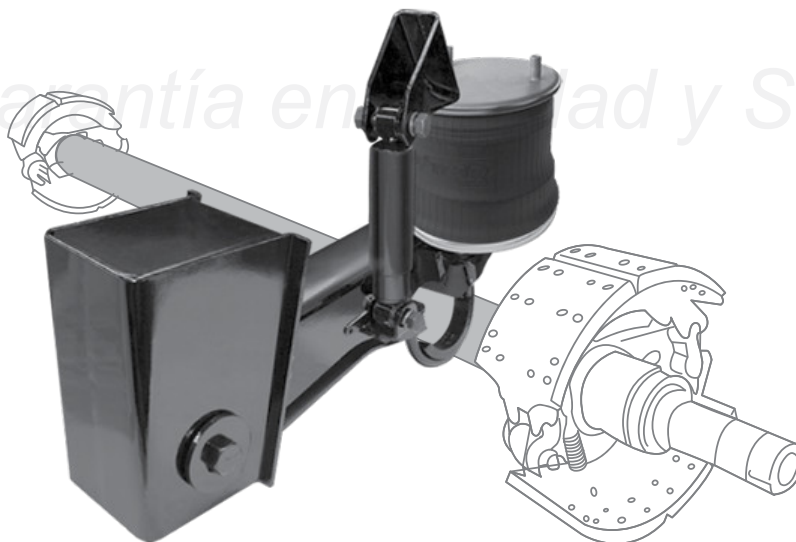

Para mayor información consulte al ejecutivo de ventas

CHRYSLER

DODGE D600 Modelo 74 - 87 Muelle DD825

PERCHA DEL. DEL.
#1



CÓDIGO: 14091
No. MAF: 7168-A

MAF

PERCHA DEL. TRAS.
#2



CÓDIGO: 14100
No. MAF: 7179-B

MAF

BUJE FIERRO Y HULE



CÓDIGO: 06081R
No. MAF: RB-135

MAF

A-6-E ALBARDÓN



CÓDIGO: 03017
No. MAF: A-6-E

MAF

TC-716 7/16"
X 4.00" T.C. COM.

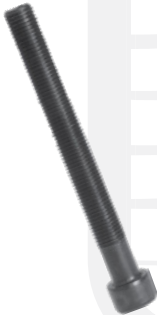

CÓDIGO: 19211
No. MAF: TC-716-4

MAF

TUERCA UNF 2
DE 7/16"



CÓDIGO: 20046
No. MAF: TLF11

MAF

Garantía en Calidad y Servicio

DINA

TRACTO-CAMIÓN DINA
S-600 Modelo 94-98
MUELLE DID234

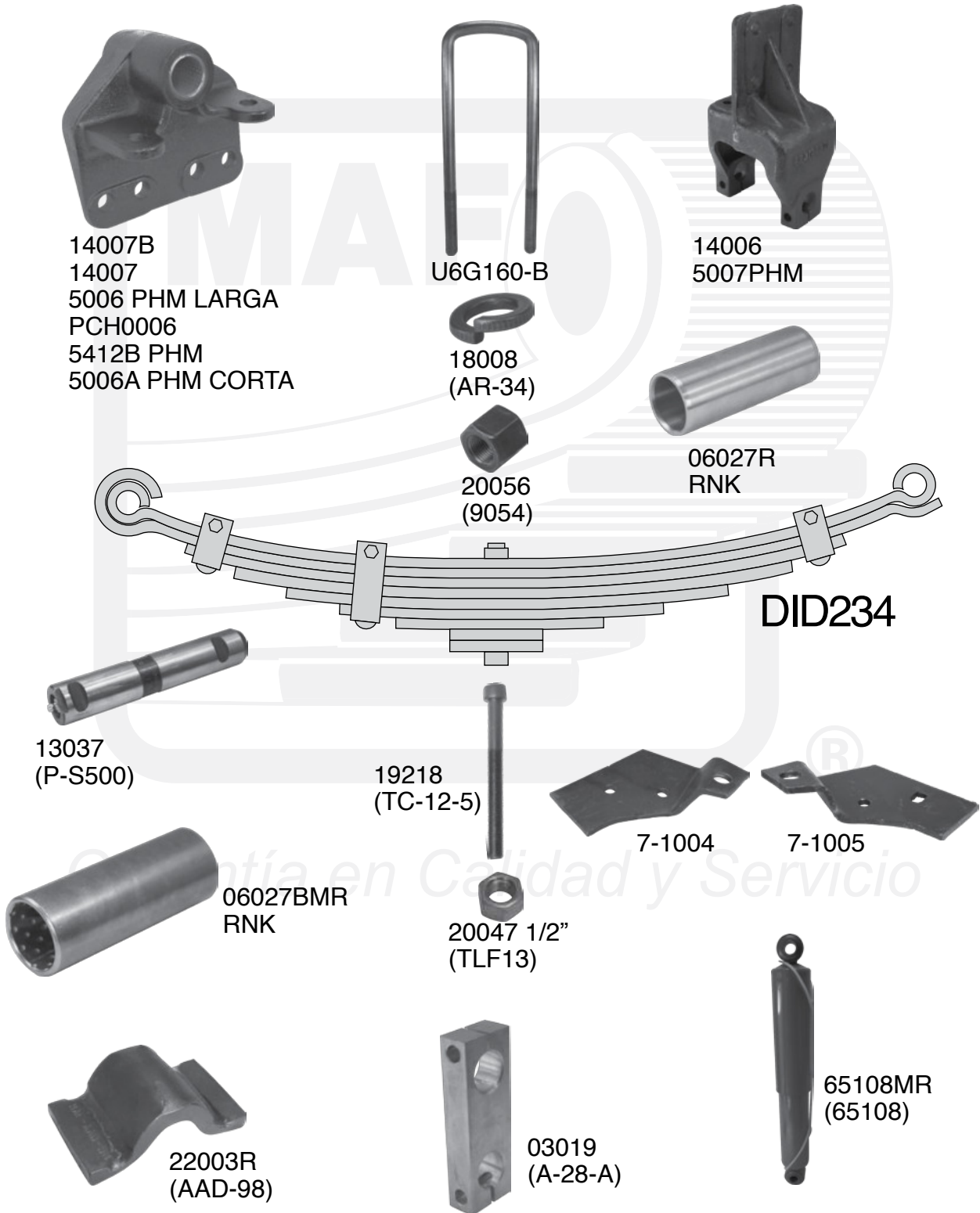

14007B
14007
5006 PHM LARGA
PCH0006
5412B PHM
5006A PHM CORTA

U6G160-B

14006
5007PHM

18008
(AR-34)

06027R
RNK

20056
(9054)

DID234

13037
(P-S500)

19218
(TC-12-5)

7-1004

7-1005

06027BMR
RNK

20047 1/2"
(TLF13)

22003R
(AAD-98)

03019
(A-28-A)

65108MR
(65108)

TRACTO-CAMIÓN DINA

S-600 Modelo 94-98













MUELLE DID234

CÓDIGO	No. MAF	DESCRIPCIÓN	CANTIDAD
14006	8505-A=5411	PERCHA DEL. DEL. PARTE FIJA 1 1/4" FUND.	2
5007	8505-A	PERCHA DEL. DEL. PARTE/FIJA 1 1/4 FUND.	2
14007B	8506-B	PERCHA DEL. TRA. DINA S-600 P/COL. 1.25 FUND.	2
14007	8506-A=5412-A	PERCHA DEL. TRA. DINA S-600 PERNO 1.25 FUND	2
5006	8506-A	PER. DE. TRAS. DINA S-600 S-700 P/COL 1 1/4"	2
PCH0006	PCH0006	PERCHA DELANTERA TRASERA	2
5412B	5412B	PERCHA DEL. TRAS. DINA 500 PERNO 1 1/4" FUND.	2
5006A	5006A	PERCHA SUS. DEL. BLUE BIRD PNO. 1 1/4" FUND.	2
06027BMR	RNK	BUJE BI-METÁLICO 1 1/2" x 1 1/4" x 4.00"	4
06027R	RNK	BUJE BRONCE 1 1/2" x 1 1/4" x 4.00"	4
13037	P-S 500	PERNO DINA S-500 Y S-600	4
65108MR	65108	AMORTIGUADOR MONROE = 85030 - 89940 MERITOR	2
U6G160-B	U-6G160-B	TORNILLO "U" 3/4" x 4" 1/16" x 16.00"	4
7-1004	7-1004	SOPORTE AMORTIGUADOR IZQUIERDO	2
7-1005	7-1005	SOPORTE AMORTIGUADOR DERECHO	2
22003R	AAD-98	ASIENTO ABRAZADERA	2
03019	A-28-A	ALBARDÓN	2
20056	9054	TUERCA FINA 3/4" °8	8
18008	AR-34	RONDANA DE PRESIÓN 3/4"	8
20047	TLF13	TUERCA UNF. °2 DE 1/2"	2
19218	TC-12-5	TORNILLO DE CENTRO 1/2" x 500"	2
DID234	DID234	MUELLE DE 10 HOJAS	2
		HOJA 01 4" x .447" x 25" x 29"	

VER CATÁLOGO DE MUELLES MAF 2011

DINA

TRACTO-CAMIÓN DINA S-600 Modelo 94-98 MUELLE DID234

<p>PERCHA DEL. DEL. PERNO 1 1/4" FUND.</p>  <p>CÓDIGO: 14006 No. MAF: 8505-A=5411</p>	<p>PERCHA DEL. DEL. PERNO 1 1/4" FUND. PHM</p>  <p>CÓDIGO: 5007 No. MAF: 8505A</p>	<p>PERCHA DEL. TRAS.</p>  <p>CÓDIGO: 14007B No. MAF: 8506B</p>	<p>PERCHA DEL. TRAS.</p>  <p>CÓDIGO: 14007 No. MAF: 8506A=5412A</p>
<p>PERCHA DEL. TRAS.</p>  <p>CÓDIGO: 5006 No. MAF: 8506A</p>	<p>PERCHA DEL. TRAS.</p>  <p>CÓDIGO: PCH0006 No. MAF: PCH0006</p>	<p>PERCHA DEL. TRAS.</p>  <p>CÓDIGO: 5412B No. MAF: 5412B</p>	<p>PERCHA SUS. DEL.</p>  <p>CÓDIGO: 5006A No. MAF: 5006A</p>
<p>BUJE BI-METÁLICO 1 1/2" X 1 1/4" 4.00"</p>  <p>CÓDIGO: 06027BMR No. MAF: RNK</p>	<p>BUJE BRONCE 1 1/2" X 1 1/4" X 4.00"</p>  <p>CÓDIGO: 06027R No. MAF: RNK</p>	<p>PERNO</p>  <p>CÓDIGO: 13037 No. MAF: P-S500</p>	<p>AMORTIGUADOR MONROE</p>  <p>CÓDIGO: 65108MR No. MAF: 65108</p>

DINA

TRACTO-CAMIÓN DINA
S-600 Modelo 94-98
MUELLE DID234

TORNILLO "U"
3/4 X 4 1/16 X 16.00



CÓDIGO: U6G160-B
No. MAF: U-6G160-B

SOPORTE
AMORTIGUADOR
INFERIOR



CÓDIGO: 7-1004
No. MAF: 7-1004

SOPORTE
AMORTIGUADOR
INFERIOR



CÓDIGO: 7-1005
No. MAF: 7-1005

ASIENTO
ABRAZADERA



CÓDIGO: 22003R
No. MAF: AAD-98

ALBARDÓN



CÓDIGO: 03019
No. MAF: A-28-A

TUERCA FINA ALTA
3/4" 8



CÓDIGO: 20056
No. MAF: 9054

RONDANA DE
PRESIÓN 3/4"



CÓDIGO: 18008
No. MAF: AR-34

TUERCA UNF.
2 DE 1/2"



CÓDIGO: 20047
No. MAF: TLF 13

Garantía en Calidad y Servicio

DINA

DINA SERIE S-500
Modelo 92-94 MUELLE DID510

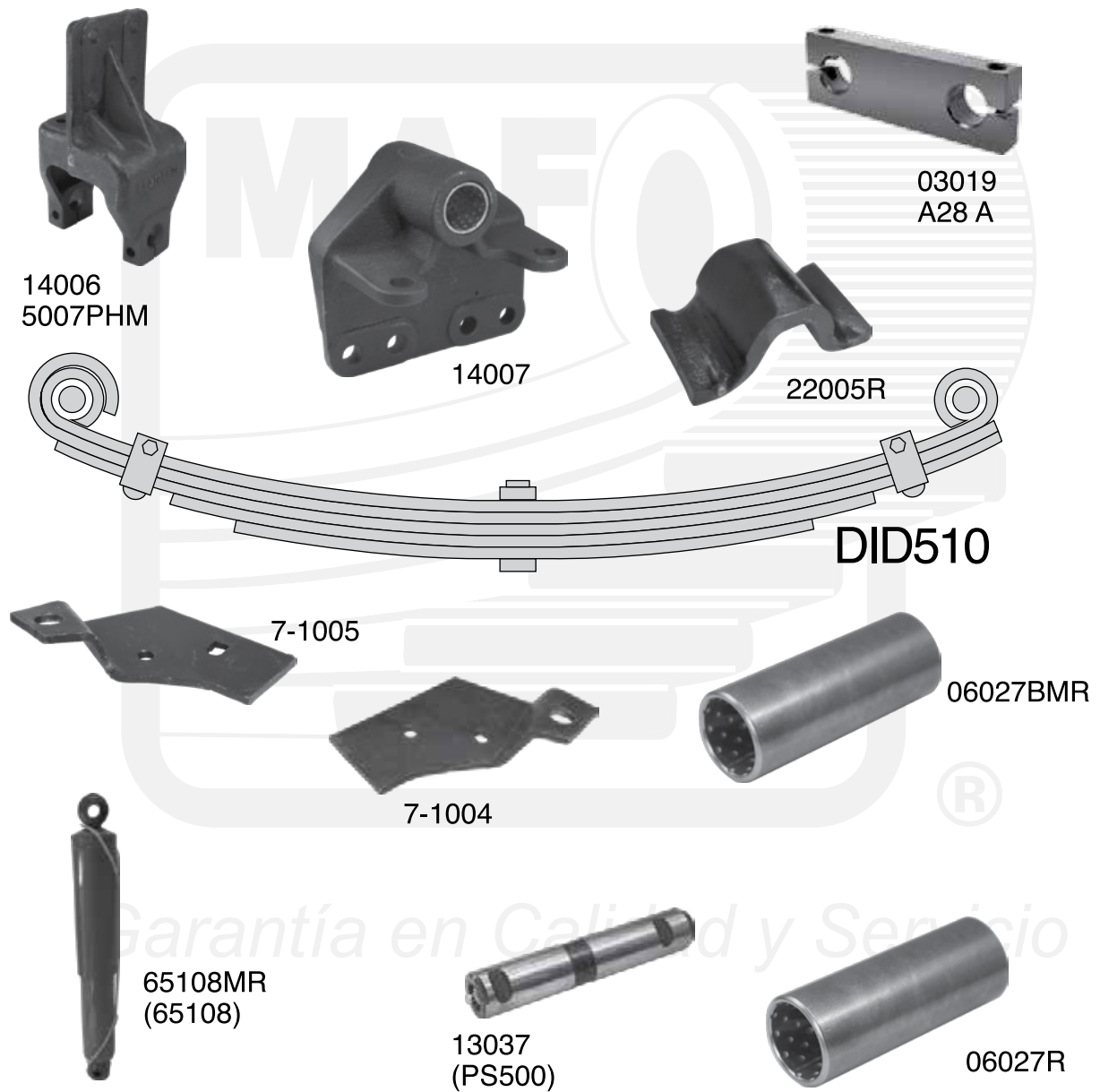

DINA

DINA SERIE S-500

Modelo 92-94 MUELLE DID510

CÓDIGO	No. MAF	DESCRIPCIÓN	CANTIDAD
14006	8505-A = 5411	8505-A PERCHA DEL. DEL. DINA 500-700 PERNO 1 1/4"	2
14007	8506-A = 5412-A	8506-A PERCHA DEL. TRA. DINA S-600 PERNO 1 1/4"	2
03019	A-28-A	A-10-M ALBARDÓN DINA S-400-500	4
13037	P-S500	P-S500 PERNO DINA S-500 (#M.POWER MPS-5)	4
22005R	AAD-99	AAD-99 ASIENTO ABRAZADERA DINA S-500	2
06027R	RNK 254-2	BUJE BRONCE 1 1/2" x 1 1/4" x 4.00" RNK 254-2	4
7-1004	7-1004	SOP. AMORT. INF. P/RABÓN DEL MUELLE DE 4" IZQ. SOP. INF.	2
7-1005	7-1005	AMORTIGUADOR P/RABÓN DEL MUELLE DE 4" DER.	2
65108MR	65108	AMORTIGUADOR MONROE = 85030-89940 MERITOR	2
DID510	DID510	MUELLE DE 5 HOJAS	2
06027BMR	RNK	BUJE BI-METÁLICO 1 1/2" x 1 1/4" x 4.00"	4
		HOJA 01 4" x .499" x 25" x 29" BUJE RNK	

VER CATÁLOGO DE MUELLES MAF 2011



Suspensión MAF 300

Productos MAF para otras aplicaciones



Para mayor información consulte al ejecutivo de ventas

DINA

DINA SERIE S-500
Modelo 92-94 MUELLE DID510

PERCHA DEL. DEL.
DINA 500-700 PERNO
1 1/4"



CÓDIGO: 14006
No. MAF: 8505-A

8506-A PERCHA DEL.
TRA. DINA S-600
PERNO 1 1/4"



CÓDIGO: 14007
No. MAF: 8506-A

A-28-A ALBARDON
DINA S-400-500



CÓDIGO: 03019
No. MAF: A-28-A

P-S500 PERNO DINA
S-500(#POWER MPS-5)



CÓDIGO: 13037
No. MAF: P-S500

AAD-99 ASIENTO
ABRAZADERA DINA
S-500



CÓDIGO: 22005R
No. MAF: AAD-99

BUJE BRONCE
1 1/2" X 1 1/4 X4.00
RNK 254-2



CÓDIGO: 06027R
No. MAF: RNK254-2

SOP. AMORT INFERIOR
P/RABON DEL MUELLE
DE 4" IZQ



CÓDIGO: 7-1004
No. MAF: 7-1004

SOP. AMORT INFERIOR
P/RABON DEL MUELLE
DE 4" DER



CÓDIGO: 7-1005
No. MAF: 7-1005

AMORT. MONROE =
85030-89940 MERITOR



CÓDIGO: 65108MR
No. MAF: 65108

Garantía en Calidad y Servicio

DINA

DINA URBANO 604, S-600
MUELLE DIT604

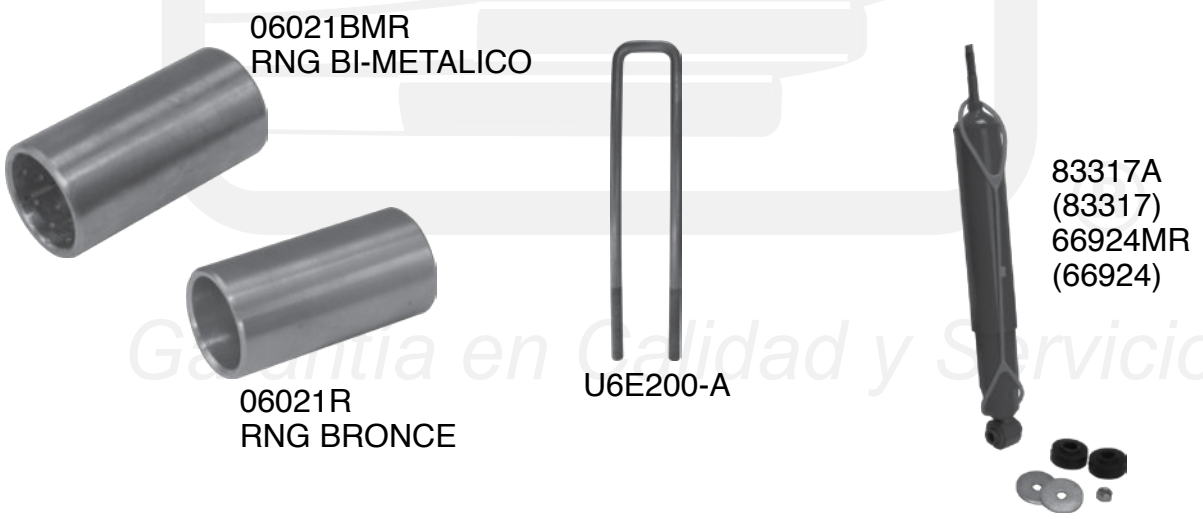
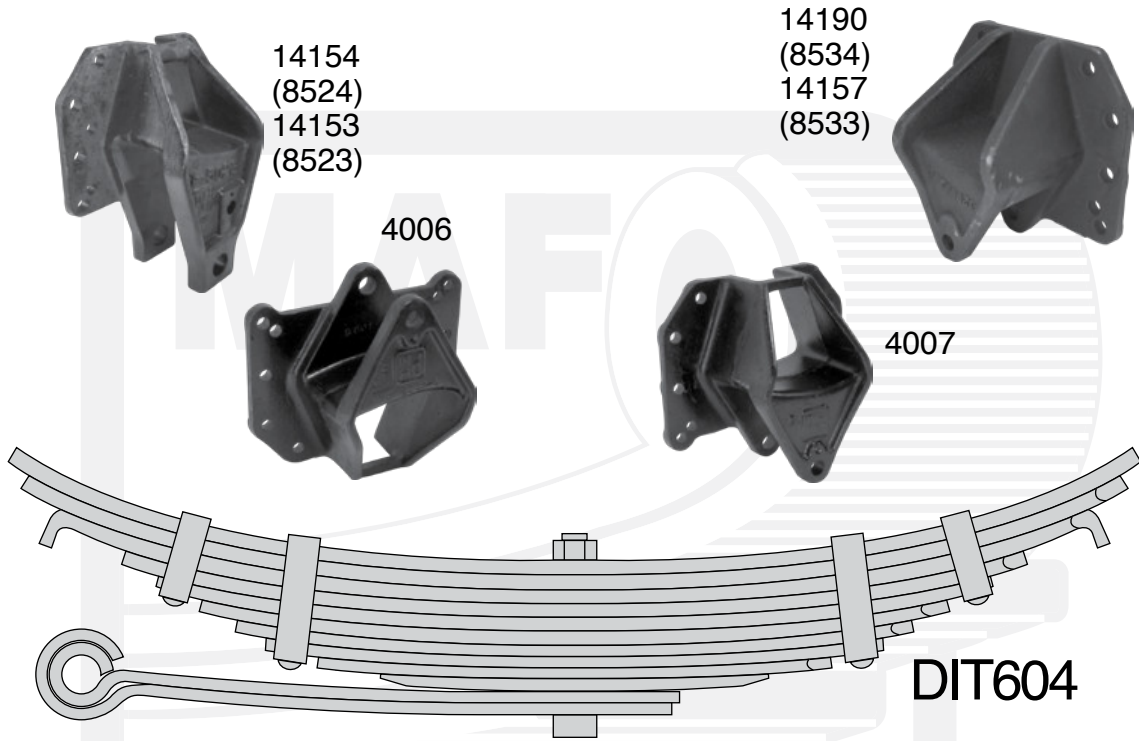

Garantía en Calidad y Servicio

DINA URBANO 604, S-600 MUELLE DIT604

CÓDIGO	No. MAF	DESCRIPCIÓN	CANTIDAD
83317A	83317	AMORT. MERITOR = 66924 MONROE K374-26	2
66924MR	66924	AMORT. MONROE = 83317 MERITOR	2
06021R	RNG	BUJE BI-METÁLICO 1 1/2" x 1 1/4" x 3.00" RNG	1
06021BMR	RNG BI-METALICO	BUJE BI-METÁLICO 1 1/2" x 1 1/4" x 3.00"	1
U6E200-A	U-6E200-A	TORNILLO "U" 3/4 x 3 1/16 x 20.00"	4
14190	8534 DER	PERCHA #4 TRAS. TRAS. DER. FUND.	2
14157	8533=8831	PERCHA #4 TRAS. TRAS. IZQ. FUND.	2
14154	8524=8522	PERCHA #3 TRAS. DEL. DER. PHM 5027 FUND.	2
14153	8523=8521	PERCHA #3 TRAS. DEL. IZQ. PHM 5028 FUND.	2
4006	4006	PERCHA TRASERA IZQ. DINA TIPO VIEJO	2
4007	4007	PERCHA TRASERA DER. DINA TIPO VIEJO	2
DIT604	DIT-604	MUELLE DE 12 HOJAS	2
		HOJA 01 3" x .499" x 38" x 38"	
		HOJA GUÍA 3" x .499" x 33 1/8" x 3 3/8"	

VER CATÁLOGO DE MUELLES MAF 2011



Garantía en Calidad y Servicio

DINA

DINA URBANO 604, S-600 MUELLE DIT604

AMORT. MERITOR
66924 MONROE
374-26



CÓDIGO: 83317A
No. MAF: 83317

MAF

AMORT. MONROE
83317 MERITOR



CÓDIGO: 66924MR
No. MAF: 66924

MAF

BUJE BRONCE
1 1/2" X 1 1/4" X 3.00"



CÓDIGO: 06021R
No. MAF: RNG

MAF

BUJE BI-METÁLICO
1 1/2" X 1.260" X 3.00"



CÓDIGO: 06021BMR
No. MAF: RNG
BI-METALICO

MAF

TORNILLO "U"
3/4" X 3 1/16 X 20.00



CÓDIGO: U6E200-A
No. MAF: U-6E200-A

MAF

PERCHA
TRAS. TRAS. DER.



CÓDIGO: 14190
No. MAF: 8534 DER

MAF

PERCHA TRAS.
TRAS. IZQ.



CÓDIGO: 14157
No. MAF: 8533=8531

MAF

PERCHA TRAS.
DEL. DER.



CÓDIGO: 14154
No. MAF: 8524=8522

MAF

PERCHA TRAS.
DEL. IZQ.



CÓDIGO: 14153
No. MAF: 8523=8521

MAF

PERCHA TRASERA IZQ.
DINA TIPO VIEJO



CÓDIGO: 4006
No. MAF: 4006

MAF

PERCHA TRASERA
DER. DINA TIPO VIEJO



CÓDIGO: 4007
No. MAF: 4007

MAF

DINA / NAVISTAR

DINA NAVISTAR

SUSPENSIÓN TANDEM

HENDRICKSON RT/RT2 DIT664

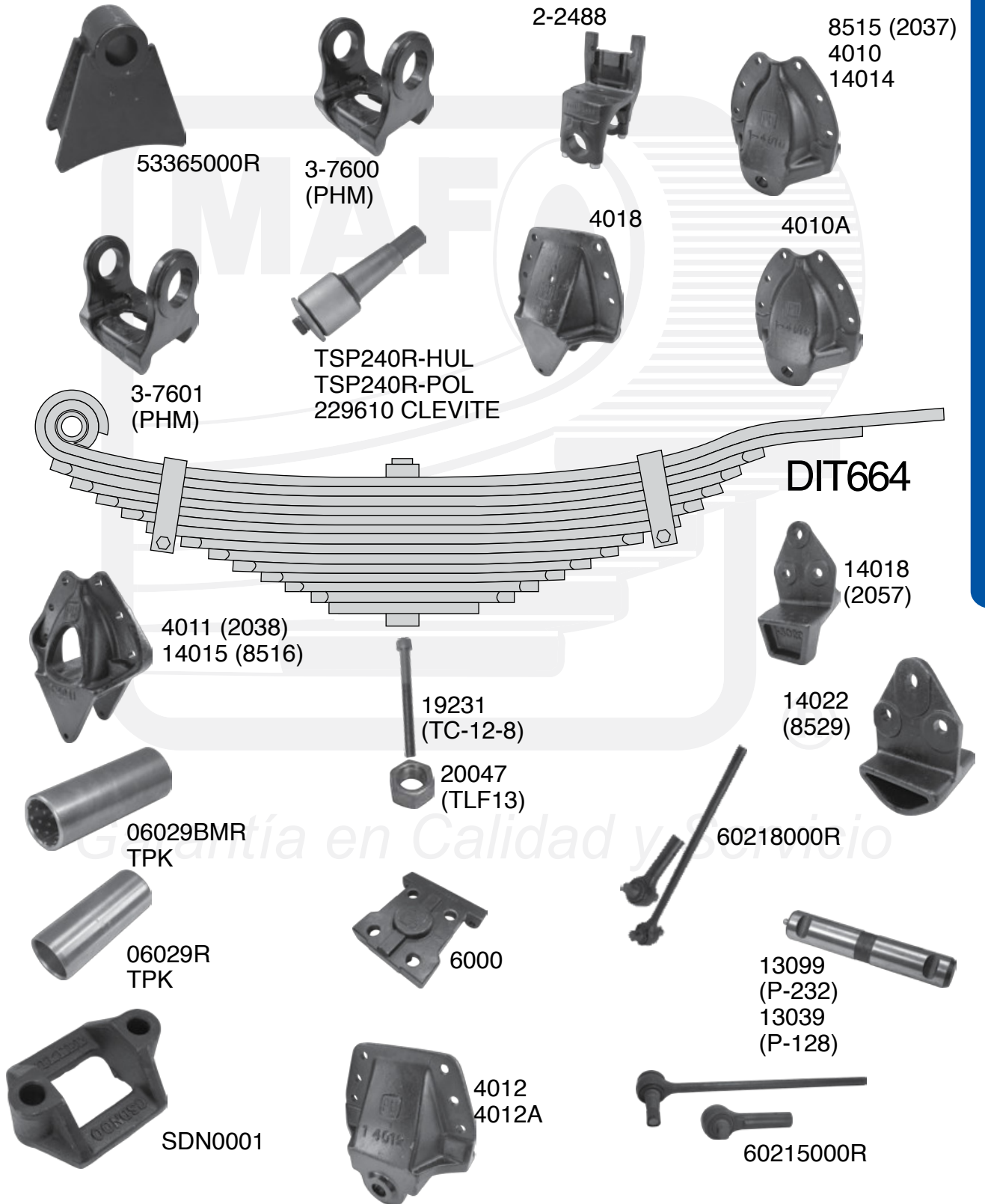

DINA / NAVISTAR

DINA NAVISTAR SUSPENSIÓN TANDEM HENDRICKSON RT/RT2 DIT664



9039DT
POLIURETANO



BP200



53090000R



53250000C
5325 CLEVITE



30437000R



TSP223J-POL
200420KP



403740PC
403740



13548



53525000R



200420K



34013087R

DINA / NAVISTAR

DINA NAVISTAR SUSPENSIÓN TANDEM HENDRICKSON RT/RT2 DIT664

CÓDIGO	No. MAF	DESCRIPCIÓN	CANTIDAD
60218000R	60218-000	BARRA DE TORSIÓN TRANS. ESTILO ESPARRAGADO	2
60215000R	60215-000	BARRA DE TORSIÓN TRANS. CÓNICA ULTRA ROD. AJUS.	2
SDN0001	SDN0001	SOPORTE P/BRAZO DE TORSIÓN DINA 881=22186000R	2
53365000R	53365-000	SOPORTE P/BARRA TORSIÓN TRANSVER. HEND.	2
4018	4018	PERCHA INTERMEDIA CENTRADA FUNDICIÓN	2
4011	8516 (2038)	PERCHA TRASERA INTERMEDIA #2	2
14015	2038 = 8516	PERCHA TRASERA INTERMEDIA PHM 40100 FUND.	2
4010A	4010A	PERCHA DEL. SUSPENSIÓN TRAS. PERNO 1 1/4" HEND.	2
4010	8515 (2037)	PERCHA TRASERA DELANTERA #1 FAMSA	2
14014	2037 = 8515	PERCHA TRASERA DELANTERA PHM 4010 FUND.	2
4012A	4012A	PERCHA DEL PERNO 1 1/4" RTE.	2
4012	8518	PERCHA TRAS. DEL. #1 DIMA 800 1 3/8"	2
13099	P-232	PERNO HENDRICKSON (# M.POWER MP-233)	2
13039	P-128	PERNO HENDRICKSON	2
6000	6000	SOBRE MUELLE	2
14018	2057=PHM5020	PERCHA TRASERA TRASERA FUNDICIÓN	2
14022	8529=PCH0118	PERCHA TRASERA TRASERA FUNDICIÓN	2
44643009LR	44643-09L	TUBO TRANSVERSAL RT	1
44642008LR	44642-008L	TUBO TRANSVERSAL RT 340	1
28129	13507	ADAPTADOR DE BUJES LATERALES (GAFF) PHM 026C	4
4500007LR	45000-07L	KIT ADAPTADOR 380-440	4
BP200	BP200	KIT GRANADA HEND. BEAM NVO. ESTILO 34013-088	4
34013088LR	34013-088L	BUJE BAR PIN ALINEABLE "HN"	4
20034013KP	200-34013KP	BUJE LATERAL BAR PIN ALINEABLE	4
34013087R	34013-087	BUJE BAR PIN NO ALINEABLE "HN"	4
20034013P	200-34013P	BUJE LATERAL BAR PIN NO ALINEABLE	4
53525000R	53525-000	53525-000 KIT DE BUJES SIN ADAPTADOR HEND.	2
53250000C	5325 CLEVITE	KIT DE BUJES CLEVITE C/ADAPTADOR MIG. HEND.	2
20047	TLF13	TUERCA HEX. LIVIANA FINA DE 1/2" °2	2
403740PC	403740	BUJE BAR PIN SOLO 2 LAINAS DE ALINEACIÓN	2

DINA / NAVISTAR

DINA NAVISTAR SUSPENSIÓN TANDEM HENDRICKSON RT/RT2 DIT664

CÓDIGO	No. MAF	DESCRIPCIÓN	CANTIDAD
53250000R	53250-000	KIT DE BUJES CON ADAPTADOR HENDRICKSON	2
53090000R	53090-000	KIT DE BUJES DE BRONCE C/ADAPTADOR HEND.	2
200420KP	200-420KP	JGO. BUJES P/VIGA IGUAL. 44000LBS TSP223J-POL.	2
200420K	200-420K	KIT DE BUJES PARBO C/ADAPTADOR	2
13548	13548	KIT DE 2 BUJES CENTRALES Y 4 LATERALES	2
9040DT	9040-D	BUJE LATERAL P/VIGA SUSPENSIÓN 4400LB HEND.	4
9039DT	9039-D	BUJE CENTRAL P/VIGA DE SUSPENSIÓN HEND.	2
45900000R	45900-000	BUJE LATERAL HEND. 5 3/4 340/343/403	4
233283	45900000	BUJE CHICO P/KIT CLEVITE. 53250000	4
06969000R	06969-000	BUJE LATERAL 34000LBS. 340 EXTREMO	4
3-7601	37601	ARETE INCLINADO PHM	2
3-7600	37600	ARETE RECTO PHM	2
49400000R	49400-000	BUJE CENTRAL HENDRICKSON 340/343/403	2
30437000R	30437-000	KIT DE BUJES BRONCE (SOLO CENTRALES)	2
110223	05919000	BUJE GRANDE DE P/KIT 53250000	2
06664000R	06664-000	06664-000 BUJE CENTRAL 34000LBS	2
TSP223J-POL	TSP223J	13508=H53012 JUEGO BUJES POLIURETANO	2
TSP240R-HUL	200-4497	GRANADA CÓNICA	2
2-2488	2-2488	SILLA DE 6"	2
06029BMR	TPK	BUJE BI-METÁLICO 1 5/8" x 1.3" x 4.00" TPK	2
06029R	TPK	BUJE BRONCE 1 5/8" x 1 3/8" x 4.00" TPK	2
19221	TC-12-10	TORNILLO DE CENTRO 1/2" x 10"	2
DIT664	DIT-664	MUELLE COMPLETA 14 HOJAS	2
		4" x .499" x 17" x 28 1/2"	

VER CATÁLOGO DE MUELLES MAF 2011

DINA / NAVISTAR DINA NAVISTAR SUSPENSIÓN TANDEM HENDRICKSON RT/RT2 DIT664

**BARRA DE TORSIÓN
TRANSVERSAL**



CÓDIGO: 60218000R
No. MAF: 6021-8000

**BARRA DE TORSIÓN
TRANSV. CÓNICA**



CÓDIGO: 60215000R
No. MAF: 60215-000

**SOPORTE P/BRAZO
DE TORSIÓN**



CÓDIGO: SDN0001
No. MAF: SDN0001

**SOPORTE P/BARRA
DE TORSIÓN**



CÓDIGO: 53365000R
No. MAF: 53365-000

**PERCHA INTERMEDIA
CENTRAL**



CÓDIGO: 4018
No. MAF: 4018

**PERCHA TRAS.
INTERMEDIA**



CÓDIGO: 4011
No. MAF: 8516 (2038)

**PERCHA TRAS.
INTERMEDIA**



CÓDIGO: 14015
No. MAF: 2038=8516

**PERCHA DELANTERA
PERNO PIN 1 1/4"**



CÓDIGO: 4010A
No. MAF: 4010A

**PERCHA DELANTERA
PERNO PIN 3/8"**



CÓDIGO: 4010
No. MAF: 8515 (2037)

**PERCHA DELANTERA
PERNO PIN 1 3/8"**



CÓDIGO: 14014
No. MAF: 2037=8515

**PERCHA DELANTERA
PIN 1 1/4" RTE**



CÓDIGO: 4012A
No. MAF: 4012A

**PERCHA DELANTERA
PIN 1 3/8" RTE**



CÓDIGO: 4012
No. MAF: 8518

DINA / NAVISTAR

DINA NAVISTAR SUSPENSIÓN TANDEM HENDRICKSON RT/RT2 DIT664

PERNO LISO
1 3/8" X 7 1/2"



CÓDIGO: 13099
No. MAF: P-232

MAF

PERNO LISO LARGO
13/8" X 7 1/2"



CÓDIGO: 13039
No. MAF: P-128

MAF

SOBRE MUELLE
TAPA SILLA



CÓDIGO: 6000
No. MAF: 6000

MAF

PERCHA SOPORTE
EXTENSIÓN



CÓDIGO: 14018
No. MAF: 2057=PHM
5020

MAF

PERCHA SOPORTE
DE EXTENSIÓN



CÓDIGO: 14022
No. MAF: 8529

MAF

TUBO TRANSVERSAL
44 7/8" X 2 7/16"



CÓDIGO: 44643009L
No. MAF: 44643-09L

MAF

TUBO TRASVERSAL
44 7/8" X 1 15/16"



CÓDIGO: 44642008L
No. MAF: 44642-008L

MAF

ADAPT. P/ DE BUJES
LAT. PHM 026C



CÓDIGO: 28129
No. MAF: 13507

MAF

KIT ADAPTADOR
308-440



CÓDIGO: 4500007LR
No. MAF: 45000-07L

MAF

KIT GRANADA BEAM
NVO. ESTILO



CÓDIGO: BP200
No. MAF: BP200

MAF

BUJE BAR PIN
ALINEABLE "HN"



CÓDIGO: 34013088LR
No. MAF: 34013-088L

MAF

BUJE LATERAL BAR
PIN ALINEABLE



CÓDIGO: 20034013KP
No. MAF: 20034013KP

MAF

DINA / NAVISTAR DINA NAVISTAR SUSPENSIÓN TANDEM HENDRICKSON RT/RT2 DIT664

**BUJE LATERAL BAR
PIN NO ALINEABLE**



CÓDIGO: 34013087R
No. MAF: 34013-087

**BUJE LATERAL BAR
PIN NO ALINEABLE**



CÓDIGO: 20034013P
No. MAF: 200-34013P

**KIT DE BUJES
SIN ADAPTADOR**



CÓDIGO: 53525000R
No. MAF: 53525-000

**KIT DE BUJES CLEVITE
C/ADAPTADOR**



CÓDIGO: 53250000C
No. MAF: 5325 CLEVITE

**KIT DE BUJES
C/ADAPTADOR**



CÓDIGO: 53250000R
No. MAF: 53250-000

**KIT DE BUJES DE
BRONCE C/
ADAPTADOR**



CÓDIGO: 53090000R
No. MAF: 53090-000

**JGO. BUJES P/VIGA
IGUALADORA
POLIURETANO**



CÓDIGO: 200420KP
No. MAF: 200-420KP

**KIT DE BUJES PARBO
C/ADAPTADOR**



CÓDIGO: 200420K
No. MAF: 200-420K

**KIT DE 2 BUJES
CENT. Y 4 LATERALES
POLIURETANO**



CÓDIGO: 13548
No. MAF: 13548

**BUJE LATERAL
PARA VIGA**

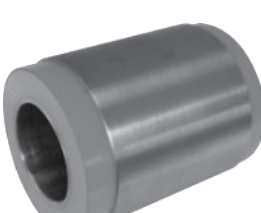

CÓDIGO: 9040DT
No. MAF: 9040-D

**BUJE POLIURETANO
CENTRAL PARA VIGA**



CÓDIGO: 9039DT
No. MAF: 9039-D

**BUJE LATERAL 5 3/4
340/343/403**



CÓDIGO: 45900000R
No. MAF: 45900-000

DINA / NAVISTAR

DINA NAVISTAR SUSPENSIÓN TANDEM HENDRICKSON RT/RT2 DIT664

BUJE CHICO
P/KIT 53250000



CÓDIGO: 233283
No. MAF: 45900000

MAF

BUJE LATERAL
34000 LBS



CÓDIGO: 06969000R
No. MAF: 06969-000

MAF

ARETE INCLINADO
PHM



CÓDIGO: 3-7601
No. MAF: 37601

MAF

ARETE RECTO
PHM



CÓDIGO: 3-7600
No. MAF: 37600

MAF

BUJE CENTRAL
340/343/403



CÓDIGO: 49400000R
No. MAF: 49400-000

MAF

KIT DE BUJES BRONCE
(SOLO CENTRALES)



CÓDIGO: 30437000R
No. MAF: 30437-000

MAF

BUJE CENTRAL



CÓDIGO: 110223
No. MAF: 05919000

MAF

BUJE CENTRAL
34000 LBS



CÓDIGO: 06664000R
No. MAF: 06664000

MAF

CONJUNTO DE BUJES
EN POLIURETANO



CÓDIGO: TSP223J-POL
No. MAF: TSP223J

MAF

SILLA
6,00" 44000 LBS



CÓDIGO: 2-2488
No. MAF: 2-2488

MAF

BUJE BI-METÁLICO
1 5/8" X 1.385" 4.00" TPK



CÓDIGO: 06029BMR
No. MAF: TPK

MAF

BUJE BRONCE
1 5/8" X 1.375 X 4.00 TPK



CÓDIGO: 06029R
No. MAF: TPK

MAF

DINA / NAVISTAR

DINA NAVISTAR SUSPENSIÓN TANDEM HENDRICKSON RT/RT2 DIT664

TUERCA HEX. LIVIANA
FINA DE 1/2" Ø2



CÓDIGO: 20047
No. MAF: TLF13

MAF

TORNILLO DE CENTRO
1/2" X 8"



CÓDIGO: 19221
No. MAF: TC-12-10

MAF

BUJE BAR PIN SOLO 2
LAINAS DE
ALINEACIÓN



CÓDIGO: 403740PC
No. MAF: 403740

MAF

GRANADA TENSORA
CÓNICA



TSP240R-HUL
TSP240R-POL
229610 CLEVITE

MAF



Ejes para remolque

Productos MAF para otras aplicaciones

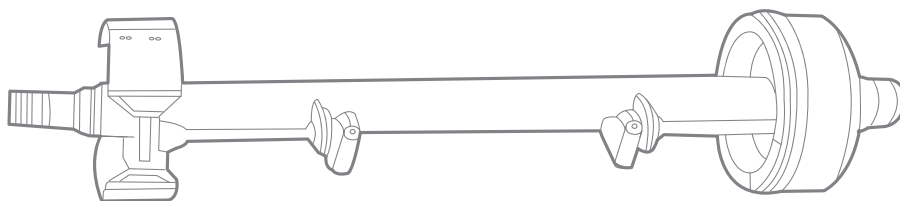

Para mayor información consulte al ejecutivo de ventas

DINA / NAVISTAR

DINA-NAVISTAR TRACTOR S700-S-9400 HENDRICKSON RTE-340/RTE2- 340 DIT836



53365000R



3-7600PHM

2-2488



8515 (2037)
4010
14014



3-7601PHM



TSP240R-HUL
TSP240R-POL
229610 CLEVITE

4018



4010A

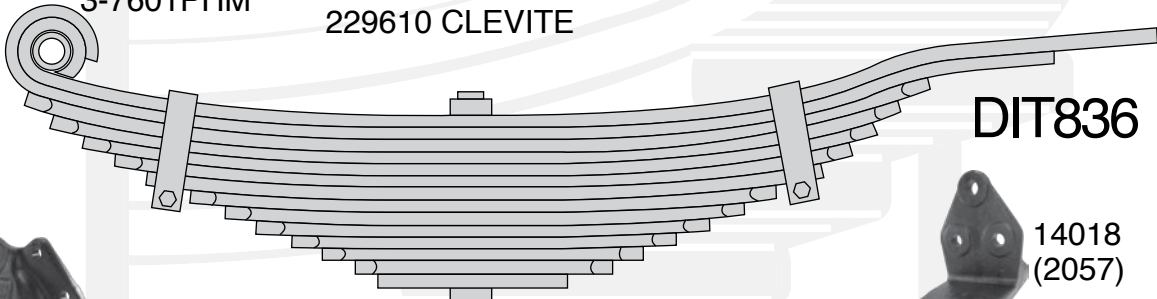

DIT836



4011 (2038)
14015 (8516)



14018
(2057)



19231
(TC-12-8)

14022
(8529)



06929R
TPK



20047
(TLF13)



60218000R



4012
4012A



6000

13099
(P-232)
13039
(P-128)



SDN0001

13039
(P-128)



60215000R



06029BMR
TPK

DINA / NAVISTAR

DINA -NAVISTAR TRACTOR S700-S-9400 HENDRICKSON RTE-340/RTE2- 340 DIT836



DINA / NAVISTAR

DINA-NAVISTAR TRACTOR S700-S-9400 HENDRICKSON RTE-340/RTE2- 340 DIT836

CÓDIGO	No. MAF	DESCRIPCIÓN	CANTIDAD
60218000R	60218-000	BARRA DE TORSIÓN TRANS. ESTILO ESPÁRRAGO	2
60215000R	60215-000	BARRA DE TORSIÓN TRANS. CÓNICA ULTRA ROD. AJUS.	2
SDN0001	SDN0001	SOPORTE P/ BRAZO DE TORSIÓN DINA 881 =22186000R	2
53365000R	53365-000	SOPORTE P/BARRA TORSIÓN TRANSVERSAL HEND.	2
4018	4018	PERCHA INTERMEDIA CENTRADA FUNDICIÓN	2
4011	8516 (2038)	PERCHA TRASERA INTERMEDIA #2	2
14015	2038=8516	PERCHA TRASERA INTER. PHM 4011 FUNDICIÓN	2
4010A	4010A	PERCHA DEL. SUS. TRA. PERNO 1 1/4" HENDRICKSON	2
4010	8515 (2037)	PERCHA TRAS. DEL #1 FAMSA	2
14014	2037=8515	PERCHA TRAS. DEL. PHM 4010 FUNDICIÓN	2
4012A	4012A	PERCHA DELANTERA PERNO 1 1/4" RTE	2
4012	8518	PERCHA TRAS. DEL. #1 DINA 800 1 3/8"	2
13099	P-232	PERNO HENDRICKSON (# M.POWER MP-233)	2
13039	P-128	PERNO HENDRICKSON	2
6000	6000	SOBRE MUELLE	2
14018	2057=PHM 5020	PERCHA TRASERA TRASERA FUNDICIÓN	2
14022	8529=PCH0118	PERCHA TRASERA TRASERA FUNDICIÓN	2
44643009LR	44643-09L	TUBO TRANSVERSAL RT	1
44642008LR	44642-008L	TUBO TRANSVERSAL RT 340	1
28129	13507	ADAPTADOR DE BUJES LATERALES(GAFF) PHM 026C	4
4500007LR	45000-07L	KIT ADAPTADOR 380-440	4
BP200	BP200	KIT GRANADA HEND. BEAM NVO. ESTILO 34013-088	4
34013088LR	34013-088L	BUJE BAR PIN ALINEABLE HN	4
20034013KP	200-34013KP	BUJE LATERAL BAR PIN ALINEABLE	4
34013087R	34013-087	BUJE BAR PIN NO ALINEABLE HN	4
20034013P	200-34013P	BUJE LATERAL BAR PIN NO ALINEABLE	4
53525000R	53525-000	53525-000 KIT DE BUJES S/ADAPTADOR HENDRICKSON	2
53250000C	5325 CLEVITE	KIT DE BUJES CLEVITE C/ADAPTADOR MIG. HEND.	2

DINA / NAVISTAR

DINA -NAVISTAR TRACTOR S700-S-9400 HENDRICKSON RTE-340/RTE2- 340 DIT836

CÓDIGO	No. MAF	DESCRIPCIÓN	CANTIDAD
53250000R	53250-000	KIT DE BUJES CON ADAPTADOR HENDRICKSON	2
53090000R	53090-000	KIT DE BUJES DE BRONCE C/ADAPT. HEND.	2
200420KP	200-420KP	JGO. BUJES P/VIGA IGUAL. 44000LBS TSP223J-POL	2
200420K	200-420K	KIT DE BUJES PARBO C/ADAPTADOR	2
13548	13548	KIT DE 2 BUJES CENTRALES Y 4 LATERALES	2
9040DT	9040-D	BUJE LATERAL P/VIGA SUSPEN. 44000 LB HEND.	4
9039DT	9039-D	BUJE CENTRAL P/VIGA DE SUSPEN. HENDRICKSON	2
45900000R	45900-000	BUJE LATERAL HEND. 5 3/4" 340/343/403	4
233283	45900000	BUJE CHICO P/KIT HENDRICKSON 53250000	4
06969000R	06969-000	BUJE LATERAL 34,000 LBS .340" EXTREMO	4
3-7601	37601	ARETE INCLINADO PHM	2
3-7600	37600	ARETE RECTO PHM	2
49400000R	49400-000	BUJE CENTRAL HENDRICKSON 340/343/403	2
30437000R	30437-000	KIT DE BUJES BRONCE (SOLO CENTRALES)	2
110223	05919000	BUJE GRANDE P/KIT 53250000	2
06664000R	06664-000	06664-000 BUJE CENTRAL 34,000 LBS.	2
TSP223J-POL	TSP223J	13508=H53012 JUEGO BUJES POLIURETANO	2
TSP240RHUL	200-4497	GRANADA CÓNICA	2
2-2488	2-2488	SILLA HENDRICKSON 6"	2
06029BMR	TPK	BUJE BI-METÁLICO 1 5/8" x 1.385" x 4.00" TPK	2
06029R	TPK	BUJE BRONCE 1 5/8" x 1.375" x 4.00" TPK	2
20047	TLF13	TUERCA HEX. LIVIANA FINA DE 1/2" °2	2
19231	TC-12-8	TORNILLO DE CENTRO 1/2" x 8"	2
DIT836	DIT-836	MUELLE COMPLETA 12 HOJAS 4" x .558" x 17" x 28 1/2"	2

VER CATALOGO DE MUELLES MAF 2011

DINA / NAVISTAR

DINA-NAVISTAR TRACTOR S700-S-9400 HENDRICKSON RTE-340/RTE2- 340 DIT836

BARRA DE TORSIÓN
TRANSVERSAL



CÓDIGO: 60218000R
No. MAF: 6021-8000

MAF

BARRA DE TORSIÓN
TRANSV. CÓNICA



CÓDIGO: 60215000R
No. MAF: 60215-000

MAF

SOPORTE P/BRAZO
DE TORSIÓN



CÓDIGO: SDN0001
No. MAF: SDN0001

MAF

SOPORTE P/BARRA
DE TORSIÓN



CÓDIGO: 53365000R
No. MAF: 53365-000

MAF

PERCHA INTERMEDIA
CENTRAL



CÓDIGO: 4018
No. MAF: 4018

MAF

PERCHA TRAS.
INTERMEDIA



CÓDIGO: 4011
No. MAF: 8516 (2038)

MAF

PERCHA TRAS.
INTERMEDIA



CÓDIGO: 14015
No. MAF: 2038=8516

MAF

PERCHA DELANTERA
PERNO PIN 1 1/4"



CÓDIGO: 4010A
No. MAF: 4010A

MAF

PERCHA DELANTERA
PERNO PIN 3/8"



CÓDIGO: 4010
No. MAF: 8515 (2037)

MAF

PERCHA DELANTERA
PERNO PIN 1 3/8



CÓDIGO: 14014
No. MAF: 2037=8515

MAF

PERCHA DELANTERA
PIN 1 1/4 RTE



CÓDIGO: 4012A
No. MAF: 4012A

MAF

PERCHA DELANTERA
PIN 1 3/8 RTE



CÓDIGO: 4012
No. MAF: 8518

MAF

DINA / NAVISTAR
 DINA -NAVISTAR TRACTOR
 S700-S-9400 HENDRICKSON
 RTE-340/RTE2- 340 DIT836

PERNO LISO
 1 3/8" x 7 1/2"



CÓDIGO: 13099
 No. MAF: P-232

MAF

PERNO LISO LARGO
 13/8" x 7 1/2"



CÓDIGO: 13038
 No. MAF: P-128

MAF

SOBRE MUELLE
 TAPA SILLA



CÓDIGO: 6000
 No. MAF: 6000

MAF

PERCHA SOPORTE
 EXTENSIÓN



CÓDIGO: 14018
 No. MAF: 2057=PHM
 5020

MAF

PERCHA SOPORTE
 DE EXTENSIÓN



CÓDIGO: 14022
 No. MAF: 8529

MAF

TUBO TRANSVERSAL
 44 7/8" x 2 7/16"



CÓDIGO: 44643009L
 No. MAF: 44643-09L

MAF

TUBO TRASVERSAL
 44 7/8" x 1 15/16"



CÓDIGO: 44642008L
 No. MAF: 44642-008L

MAF

ADAPT. P/ DE BUJES
 LAT. PHM 026C



CÓDIGO: 28129
 No. MAF: 13507

MAF

KIT ADAPTADOR
 308-440



CÓDIGO: 4500007LR
 No. MAF: 45000-07L

MAF

KIT GRANADA BEAM
 NVO. ESTILO



CÓDIGO: BP200
 No. MAF: BP200

MAF

BUJE BAR PIN
 ALINEABLE "HN"



CÓDIGO: 34013088LR
 No. MAF: 34013-088L

MAF

BUJE LATERAL BAR
 PIN ALINEABLE



CÓDIGO: 20034013KP
 No. MAF: 200-34013KP

MAF

DINA / NAVISTAR

DINA-NAVISTAR TRACTOR S700-S-9400 HENDRICKSON RTE-340/RTE2- 340 DIT836

BUJE LATERAL BAR
PIN NO ALINEABLE



CÓDIGO: 34013087R
No. MAF: 34013-087

MAF

BUJE LATERAL BAR
PIN NO ALINEABLE



CÓDIGO: 20034013P
No. MAF: 200-34013P

MAF

KIT DE BUJES
SIN ADAPTADOR



CÓDIGO: 53525000R
No. MAF: 53525-000

MAF

KIT DE BUJES CLEVITE
C/ADAPTADOR



CÓDIGO: 53250000C
No. MAF: 5325 CLEVITE

MAF

KIT DE BUJES
C/ADAPTADOR



CÓDIGO: 53250000R
No. MAF: 53250-000

MAF

KIT DE BUJES DE
BRONCE C/
ADAPTADOR



CÓDIGO: 53090000R
No. MAF: 53090-000

MAF

JGO. BUJES P/VIGA
IGUALADORA
POLIURETANO



CÓDIGO: 200420KP
No. MAF: 200-420KP

MAF

KIT DE BUJES PARBO
C/ADAPTADOR



CÓDIGO: 200420K
No. MAF: 200-420K

MAF

KIT DE 2 BUJES
CENT. Y 4 LATERALES
POLIURETANO



CÓDIGO: 13548
No. MAF: 13548

MAF

BUJE LATERAL
PARA VIGA



CÓDIGO: 9040DT
No. MAF: 9040-D

MAF

BUJE POLIURETANO
CENTRAL PARA VIGA



CÓDIGO: 9039DT
No. MAF: 9039-D

MAF

BUJE LATERAL 5 3/4"
340/343/403



CÓDIGO: 45900000R
No. MAF: 45900-000

MAF

DINA / NAVISTAR

DINA -NAVISTAR TRACTOR
S700-S-9400 HENDRICKSON
RTE-340/RTE2- 340 DIT836

BUJE CHICO
P/KIT 53250000



CÓDIGO: 233283
No. MAF: 45900000

BUJE LATERAL
34000 LBS



CÓDIGO: 06969000R
No. MAF: 06969-000

ARETE INCLINADO
PHM



CÓDIGO: 3-7601
No. MAF: 37601

ARETE RECTO
PHM



CÓDIGO: 3-7600
No. MAF: 37600

BUJE CENTRAL
340/343/403



CÓDIGO: 49400000R
No. MAF: 49400-000

KIT DE BUJES BRONCE
(SOLO CENTRALES)



CÓDIGO: 30437000R
No. MAF: 30437-000

BUJE CENTRAL
34000 LBS



CÓDIGO: 110223
No. MAF: 05919000

BUJE CENTRAL
34000 LBS



CÓDIGO: 06664000R
No. MAF: 06664000

CONJUNTO DE BUJES
EN POLIURETANO



CÓDIGO: TSP223J-POL
No. MAF: TSP223J

SILLA
6,00" 44000 LBS



CÓDIGO: 2-2488
No. MAF: 2-2488

BUJE BI-METÁLICO
1 5/8" x 1.385" x 4.00"
TPK



CÓDIGO: 06029BMR
No. MAF: TPK

BUJE BRONCE
1 5/8" x 1.375 x 4.00 TPK



CÓDIGO: 06029R
No. MAF: TPK

DINA / NAVISTAR

DINA-NAVISTAR TRACTOR
S700-S-9400 HENDRICKSON
RTE-340/RTE2- 340 DIT836

TUERCA HEX. LIVIANA
FINA DE 1/2" 02



CÓDIGO: 20047
No. MAF: TLF13



TORNILLO DE CENTRO
1/2" x 8"



CÓDIGO: 19231
No. MAF: TC-12-8



GRANADA TENSORA
CÓNICA



CÓDIGO: TSP240R-HUL
TSP240R-POL
No. MAF: 229610
CLEVITE



Amortiguadores

Productos MAF para otras aplicaciones



Para mayor información consulte al ejecutivo de ventas

DINA / NAVISTAR

DINA NAVISTAR SUSPENSIÓN TANDEM MODELOS 94-98 DIT910

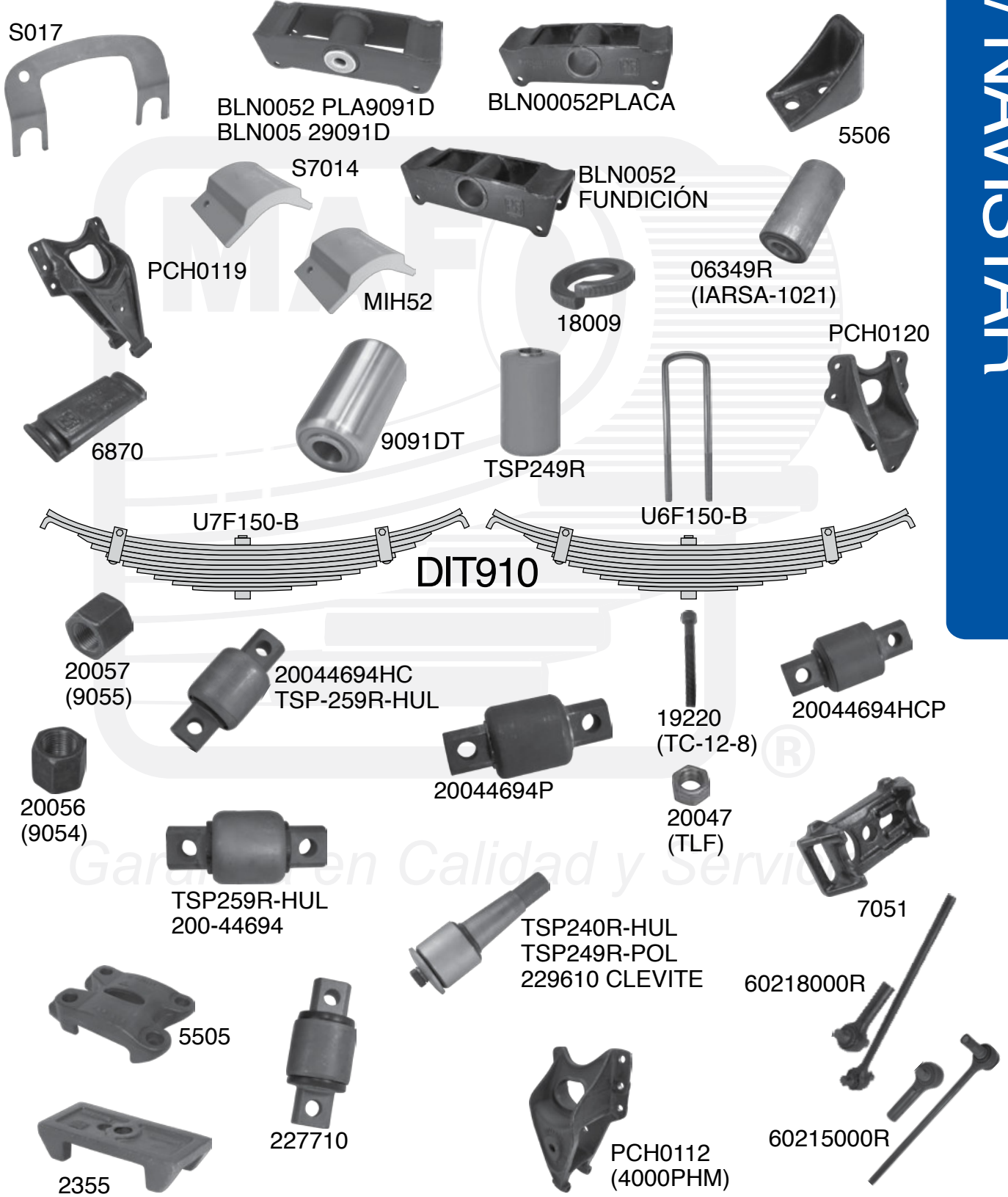

Garantía en Calidad y Servicio

DINA / NAVISTAR

DINA NAVISTAR SUSPENSIÓN
TANDEM MODELOS 94-98 DIT910

CÓDIGO	No. MAF	DESCRIPCIÓN	CANTIDAD
5505	5505	TAPA DE EJE INFERIOR	2
2355	2355	ASIENTO MUELLE C/GUÍA 1/2" x 3 1/2" x 8"	4
7051	7051	CUÑA PARA MUELLE DE 3 1/2"	4
BLN0052PLACA	BLN0052PLAC	BALANCÍN P/SUSP. (PLACA) REF. BLN0052	2
BLN0052PLA9091D	BLN0052PLA9091D	BALANCÍN PLACA C/BUJE 9091DT	2
BLN00529091D	BLN00529091D	BALANCÍN FUNDICIÓN C/BUJE 9091DT	2
BLN0052	BLN0052	BALANCÍN P/SUSP. FUNDICIÓN PHM 2185	2
PCH0120	PCH0120	PERCHA TRAS. TRAS. PHM 4002	2
5506	5506	TOPE AUXILIAR	4
PCH0112	PCH0112	PERCHA TRASERA CENTRAL FUNDICIÓN	2
PCH0119	PCH0119	PERCHA TRAS. DEL. PHM 4001 FUNDICIÓN	2
TSP249R	TSP 249-R	BUJE PARA BALANCÍN	2
TSP240R-HUL	200-44697	GRANADA CÓNICA	2
9091DT	9091-D	BUJE CENTRAL P/BALANCÍN SUSPEN. HEND.	2
06349R	IARSA-1021	BUJE CENTRAL P/BALANCÍN 497501C2 INT/NA.	2
S7014	S-7014	COJÍN (PAD) No. ORIG 571960C1	2
6870	6870	SOBRE MUELLE P/SUSPENSIÓN 3 1/2"	
4001	4001	PERCHA DEL. SUSP. MECÁNICA Y AIRE	2
S017	S017	CANGREJO DE AJUSTE 1/16" x 4 3/8"	2
20044694HC	TSP-259R-HUL	P/B TORSIÓN TRB6164 #44694 ALTO CONF. HULE	2
20044694HCP	200-44694HCP	P/B TORSIÓN TSP259R-POL ALTO CONFINAMIETO	2
20044694P	200-44694P	P/B TORSIÓN TSP259R-POL	2
227710	227710	P/B TORSIÓN TSP259R-HUL # ORIG. 44694 CLEVITE	2
GND0012	GND-0012	GRANADA	2
TSP259R-HUL	200-44694	P/B TORSIÓN	2
60218000R	60218-000	B/TORSIÓN TRANS. ESTILO ESPÁRRAGO	2

DINA / NAVISTAR

DINA NAVISTAR SUSPENSIÓN TANDEM MODELOS 94-98 DIT910

CÓDIGO	No. MAF	DESCRIPCIÓN	CANTIDAD
60215000R	60215-000	B/TORSIÓN TRANSV. CÓNICA ULTRA ROD AJUSTABLE:	2
20047	TLF13	TUERCA HEX. LIVIANA FINA DE 1/2" °2	2
19220	TCR-12-8	TORNILLO DE CENTRO 1/2" x 8.00" °8	2
U6F150-B	U-6F150-B	TORNILLO "U" 3/4" x 3 9/16" x 15.00"	2
U7F150-B	U-7F150-B	TORNILLO "U" 7/8" x 3 9/16" x 15.00"	8
20056	9054	TUERCA FINA ALTA DE 3/4" - 9054 °8	8
20057	9055	TUERCA FINA ALTA DE 7/8" - 9055 °8	8
18008	AR-34	RONDANA DE PRESIÓN 3/4" - P/REFACCIÓN	8
18009	AR-78	RONDANA DE PRESIÓN 7/8" - P/REFACCIÓN	8
DIT 910	DIT 910	MUELLE COMPLETA 9 HOJAS	4

VER CATALOGO DE MUELLES MAF 2011



Identificación del producto

Etiqueta

Garantía en Calidad y Servicio

Fecha de fabricación día 135 del año 2011

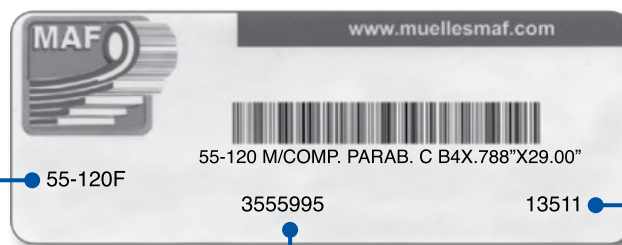

No. de parte de la hoja o muelle.

No. de orden de fabricación.

DINA / NAVISTAR

DINA NAVISTAR SUSPENSIÓN TANDEM MODELOS 94-98 DIT910

TAPA DE EJE
INFERIOR



CÓDIGO: 5505
No. MAF: 5505

MAF

ASIENTO
C/GUÍA



CÓDIGO: 2355
No. MAF: 2355

MAF

CUÑA
3 1/2"



CÓDIGO: 7051
No. MAF: 7051

MAF

BALANCÍN
(PLACA)



CÓDIGO: BLN0052placa
No. MAF: BLN0052placa

MAF

BALANCÍN PLACA
C/BUJE 9091DT



CÓDIGO: BLN0052
PLA9091D
No. MAF: BLN0052
PLA9091D

MAF

BALANCÍN FUNDICIÓN
C/BUJE 9091DT



CÓDIGO: BLN0052
9091D
No. MAF: BLN0052909D

MAF

BALANCÍN
(FUNDICIÓN)



CÓDIGO: BLN0052
No. MAF: BLN0052

MAF

PERCHA
TRAS. TRAS.



CÓDIGO: PCH0120
No. MAF: PCH0120

MAF

TOPE AUXILIAR



CÓDIGO: 5506
No. MAF: 5506

MAF

PERCHA
CENTRAL FUND.



CÓDIGO: PCH0112
No. MAF: PCH0112

MAF

PERCHA
TRAS. DEL.



CÓDIGO: PCH0119
No. MAF: PCH0119

MAF

BUJE BALANCÍN
POLIURETANO
BARRA DE TORSIÓN



CÓDIGO: TSP249R
No. MAF: TSP-249-RV

MAF

DINA / NAVISTAR

DINA NAVISTAR SUSPENSIÓN TANDEM MODELOS 94-98 DIT910

RONDANA DE PRESIÓN 7/8"



CÓDIGO: 18009
No. MAF: AR-78

BUJE CENTRAL BALANCÍN



CÓDIGO: 9091DT
No. MAF: 9091-D

BUJE CENTRAL



CÓDIGO: 713680PC
No. MAF: 713680

BUJE CENTRAL BALANCÍN F/HULE



CÓDIGO: 06349R
No. MAF: IARSA-1021

COJÍN



CÓDIGO: S7014
No. MAF: S-7014

COJÍN



CÓDIGO: MIH52
No. MAF: MIH52

SOBRE MUELLE PARA SUSP. 3 1/2"



CÓDIGO: 6870
No. MAF: 6870

PERCHA DEL PHM



CÓDIGO: 4001
No. MAF: 4001

CANGREJO DE AJUSTE



CÓDIGO: S017
No. MAF: S017

GRANADA PARA BARRA DE TORSIÓN



CÓDIGO: 20044694HC
No. MAF: TSP-259R-HUL

GRANADA PARA BARRA DE TORSIÓN ALTO CONFINAMIENTO



CÓDIGO: 20044694HCP
No. MAF: 200-44694HCP

GRANADA PARA BARRA DE TORSIÓN POLIURETANO



CÓDIGO: 20044694P
No. MAF: 200-44694P

DINA / NAVISTAR

DINA NAVISTAR SUSPENSIÓN TANDEM MODELOS 94-98 DIT910

GRANADA P/BARRA
DE TORSIÓN



CÓDIGO: 227710
No. MAF: 227710

MAF

GRANADA P/BARRA
DE TORSIÓN



CÓDIGO: 713730PC
No. MAF: 713730

MAF

GRANADA P/BARRA
DE TORSIÓN



CÓDIGO: TSP259R-HUL
No. MAF: 200-44694

MAF

TUERCA FINA ALTA
7/8" 08



CÓDIGO: 20057
No. MAF: 9055

MAF

GRANADA P/BARRA
DE TORSIÓN



CÓDIGO: TSP259-POL
No. MAF: TSP259R

MAF

BARRA DE TORSIÓN
TRANSVERSAL



CÓDIGO: 60218000R
No. MAF: 60218-000

MAF

BARRA DE TORSIÓN
TRANS. CÓNICA

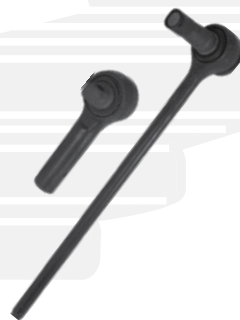

CÓDIGO: 60215000R
No. MAF: 60215-000

MAF

TORNILLO "U"
7/8" x 3 9/16" x 15.00"

CÓDIGO: U7F150-B
No. MAF: U7F150-B

MAF

TORNILLO "U"
3/4" x 3 9/16" x 15.00"



CÓDIGO: U6F150-B
No. MAF: U6F150-B

MAF

TUERCA HEX.
LIVIANA FINA 1/2" 02



CÓDIGO: 20047
No. MAF: TLF13

MAF

TORNILLO DE CENTRO
1/2" x 4.00" 08



CÓDIGO: 19220
No. MAF: TC-12-8

MAF

TUERCA FINA ALTA
3/4" 08



CÓDIGO: 20056
No. MAF: 9054

MAF

DINA / NAVISTAR

DINA NAVISTAR SUSPENSIÓN TANDEM MODELOS 94-98 DIT910

RONDANA DE PRESIÓN 3/4"



CÓDIGO: 18008
No. MAF: AR-34

MAF

TUERCA FINA ALTA 7/8" Ø8



CÓDIGO: 20057PC
No. MAF: 20057PC

MAF

TUERCA FINA ALTA 3/4" Ø8



CÓDIGO: 20056PC
No. MAF: 20056PC

MAF

GRANADA BARRA DE TORSIÓN



TSP240R-HUL
TSP240R-POL
229610 CLEVITE

MAF



Buje Trifuncional

Productos MAF para otras aplicaciones



Para mayor información consulte al ejecutivo de ventas

DINA / NAVISTAR

DINA NAVISTAR TRACTOCAMIÓN 9-400 MODELOS 90 - 00 MUELLE PARABÓLICA 55120

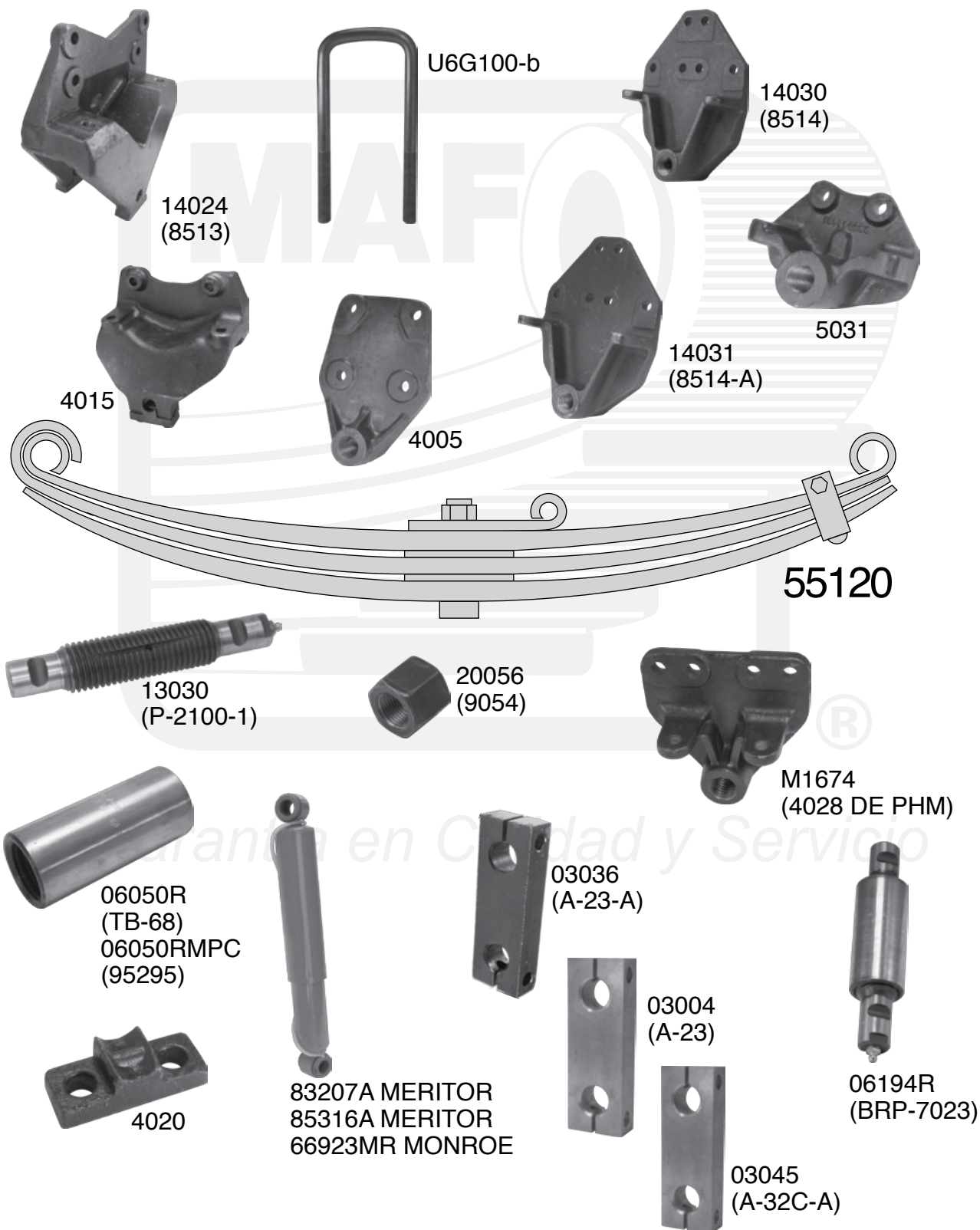

DINA / NAVISTAR

DINA NAVISTAR TRACTOCAMIÓN 9-400 MODELOS 90 - 00 MUELLE PARABÓLICA 55120

CÓDIGO	No. MAF	DESCRIPCIÓN	CANTIDAD
14024	8513	PERCHA DELANTERA DELANTERA PHM 4016	2
4015	4015	PERCHA DELANTERA DELANTERA	2
5031	5031	PERCHA	2
4020	4020	SEGURO PARA PERCHA DELANTERA.	4
M1674	M1674	PERCHA ROSCADA DINA 9400 PHM4028 FUND.	2
4005	4005	PERCHA INTER. ROSC.1 3/8,9200/9400. FUND.	2
14030	8514	PERCHA DEL. TRAS. DINA 9400 PHM 5021 FUND.	2
14031	8514-A	PERCHA DEL. TRAS. DINA 9400 IMO 5414A FUND	2
U6G100-B	U-6G100-B	TORNILLO "U" 3/4" x 4 1/16" x 10.00"	4
13030	P-2100-1	PERNO	4
06050R	TB-68	BUJE ROSCADO TB-26= TB-68	4
06050RMPC	95295	BUJE ROSCADO	4
06194R	BPR-7023	CTO. PER./BUJE DINA ÁGUILA (P-2100-1/TB-68)BPR7023	2
83207A	83207	AMORTIGUADOR MERITOR = 66886 MONROE	2
85316A	85316	AMORTIGUADOR MERITOR = 65107 MONROE	2
66923MR	66923	AMORTIGUADOR MONROE = 83102 MERITOR	2
03045	A-32C-A	ALBARDÓN ALUMINIO	4
03036	A-23-A	ALBARDÓN DINA ÁGUILA ALUMINIO	4
03004	A-23	ALBARDÓN AGUILA 9400	4
20056	9054	TUERCA FINA ALTA 3/4" - °8	4
18008	AR-34	RONDANA DE PRESIÓN 3/4"	4
55120F	55120F	MUELLE PARABÓLICA 3 HOJAS	2
		4" x .788" x 29" x 29"	

VER CATÁLOGO DE MUELLES MAF 2011

DINA / NAVISTAR

DINA NAVISTAR TRACTOCAMIÓN 9-400 MODELOS 90 - 00 MUELLE PARABÓLICA 55120

PERCHA DEL. DEL.
PHM 4016



CÓDIGO: 14024
No. MAF: 8513

MAF

PERCHA DEL. DEL.



CÓDIGO: 4015
No. MAF: 4015

MAF

SEGURO PARA
PERCHA DEL. DEL.



CÓDIGO: 4020
No. MAF: 4020

MAF

PERCHA ROSCADA
DINA 9400 PHM 4028
FUND.



CÓDIGO: M1674
No. MAF: M1674

MAF

PERCHA INTER. ROSC.
1 3/8" 9200/9400 FUND.



CÓDIGO: 4005
No. MAF: 4005

MAF

PERCHA DEL. TRAS.
DINA 9400 FUND.



CÓDIGO: 14030
No. MAF: 8514

MAF

PERCHA DEL. TRAS.
DINA 9400 PHM 5021
FUND.



CÓDIGO: 14031
No. MAF: 8514-A

MAF

TORNILLO "U"
3/4" x 4 1/16" x 10.00"



CÓDIGO: U6G100-B
No. MAF: U-6G100-B

MAF

PERNO



CÓDIGO: 13030
No. MAF: P-2100-1

MAF

BUJE ROSCADO
TB-26=TB-68MIG



CÓDIGO: 06050R
No. MAF: TB-68

MAF

BUJE ROSCADO
TB-26=TB-68
(JM TOR PAR)



CÓDIGO: 06050RMPC
No. MAF: 95295

MAF

CONJUNTO PER/BUJE
(P-2100-1/TB-68)



CÓDIGO: 06194R
No. MAF: BRP-7023

MAF

DINA / NAVISTAR

DINA NAVISTAR TRACTOCAMIÓN 9-400 MODELOS 90 - 00 MUELLE PARABÓLICA 55120

CONJUNTO PER/BUJE
(P-2100-1/TB-68)
(JM TOR PAR)



CÓDIGO: 06194RMPC
No. MAF: 09AGUILA

MAF

AMORT. MERITOR =
65107 MONROE



CÓDIGO: 85316A
No. MAF: 85316

MAF

AMORT. MERITOR =
83102 MONROE



CÓDIGO: 66923MR
No. MAF: 66923

MAF

AMORT. MERITOR =
66886 MONROE



CÓDIGO: 83207A
No. MAF: 83207

MAF

ALBARDÓN
ALUMNIO



CÓDIGO: 03036
No. MAF: A-23-A

MAF

ALBARDÓN
PLACA



CÓDIGO: 03004
No. MAF: A-23

MAF

ALBARDÓN
ALUMNIO



CÓDIGO: 03045
No. MAF: 4-32C-A

MAF

TUERCA FINA ALTA
3/4" 08



CÓDIGO: 20056
No. MAF: 9054

MAF

RONDANA DE
PRESIÓN 3/4"



CÓDIGO: 18008
No. MAF: AR-34

MAF

PERNO
ROSCADA



CÓDIGO: 5031
No. MAF: 5031

MAF

NAVISTAR INTERNATIONAL
 CAMIÓN
 NAVISTAR INTERNATIONAL 4700
 MODELOS 90-2005 ID598

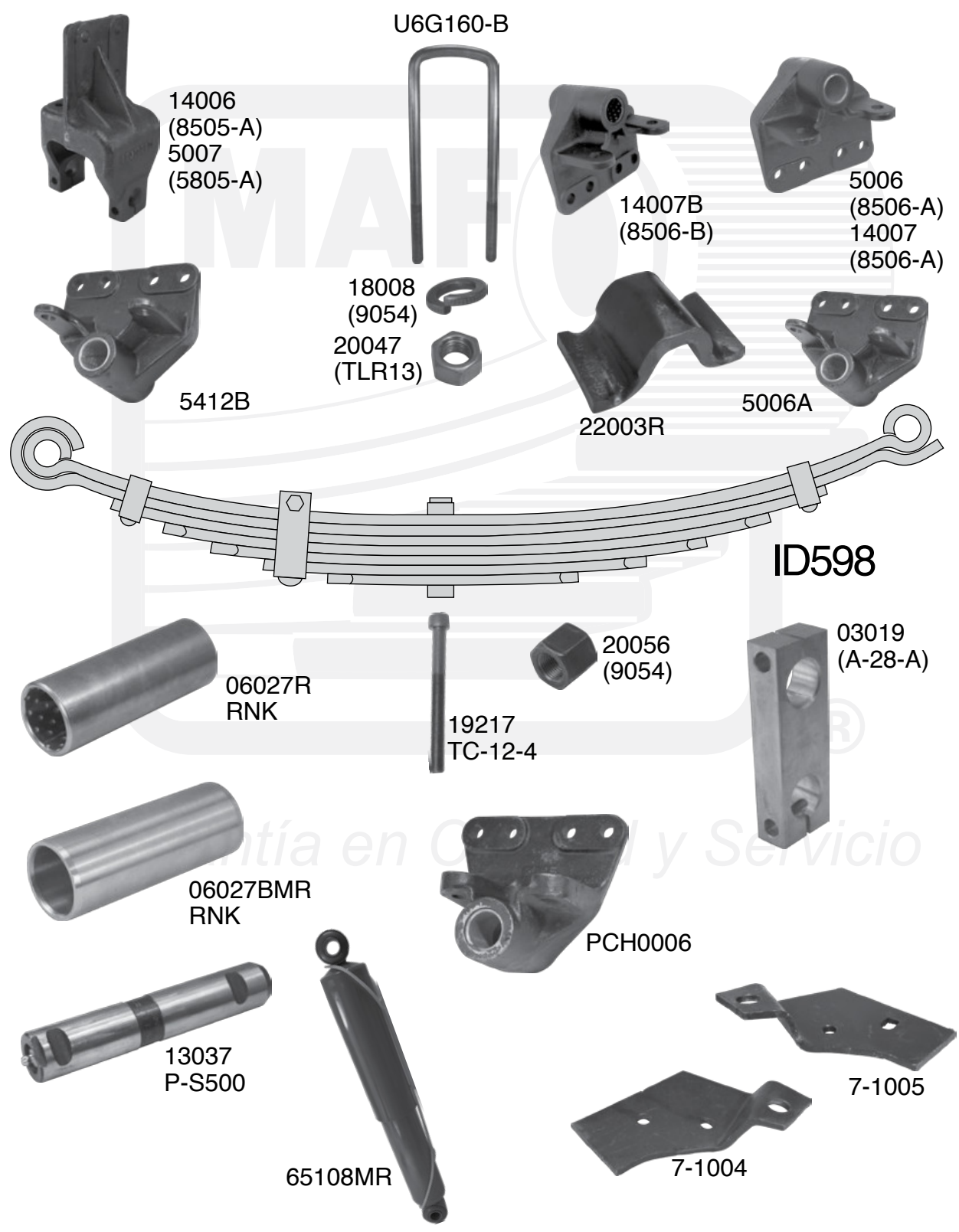

NAVISTAR INTERNATIONAL

CAMIÓN

NAVISTAR INTERNATIONAL 4700

MODELOS 90-2005 ID598

CÓDIGO	No. MAF	DESCRIPCIÓN	CANTIDAD
14006	8505-A=5411	PERCHA DEL. DEL. PERNO 1 1/4" FUND.	2
5007	8505-A	PERCHA DEL. DEL. DINA P/FIJA 1 1/4"	2
14007	8506-A	PERCHA DEL.TRA. PERNO 1 1/4 FUNDICIÓN	2
14007B	8506-B	PERCHA DEL.TRA. DINA S-600 P/COL.1.25 FUND.	2
5006	8506-A	PERCHA DEL. TRAS. P/COL 1 1/4"	2
5006A	5006A	PERCHA SUS. DEL. BLUE BIRD PNO. 1 1/4" FUND.	2
5412B	5412B	PERCHA DEL. TRAS. DINA 500 PERNO 1 1/4" FUND.	2
PCH0006	PCH0006	PERCHA DEL. TRAS. MERCEDES P/COL 1 1/4"	2
U6G160-B	U-6G160-B	TORNILLO "U" 3/4" x 4 1/16" x 16.00"	4
13037	P-S500	09682D030020 PERNO DINA S-500 Y S-600	4
06027BMR	RNK	BUJE BI-METÁLICO 1 1/2" x 1.250" x 4.00" RNK	4
06027R	RNK	BUJE BRONCE 1 1/2" x 1 1/4" x 4.00" RNK	4
03019	A-28-A	ALBARDÓN	2
22003R	AAD-98	ASIENTO ABRAZADERA	2
20047	TLF13	TUERCA FINA DE 1/2 °2	2
19217	TC-12-4	TORNILLO DE CENTRO 1/2" x 4"	2
7-1004	7-1004	SOPORTE AMORTIGUADOR IZQUIERDO	2
7-1005	7-1005	SOPORTE AMORTIGUADOR DERECHO	2
20056	9054	TUERCA FINA 3/4" °8	2
18008	AR-34	RONDANA DE PRESIÓN 3/4"	2
65108MR	65108	AMORTIGUADOR MERITOR	2
ID598	ID-598	MUELLE DE 7 HOJAS	2
		4" x 0.401" x 25" x 29" DE ROLEO 1.490" -1.498"	

PARA MAYOR DETALLE DE ESPESORES ESPECIALES
VER CATÁLOGO DE MUELLES 2011

NAVISTAR INTERNATIONAL

CAMIÓN

NAVISTAR INTERNATIONAL 4700

MODELOS 90-2005 ID598

PERCHA DEL. DEL.



CÓDIGO: 14006
No. MAF: 8505-A

PERCHA DEL. DEL.
PHM



CÓDIGO: 5007
No. MAF: 8505-A

PERCHA DEL. TRAS.



CÓDIGO: 14007
No. MAF: 8506-A

PERCHA DEL. TRAS.



CÓDIGO: 14007B
No. MAF: 8506-B

PERCHA DEL. TRAS.
PHM



CÓDIGO: 5006
No. MAF: 8500-A

PERCHA DEL. TRAS.
PHM BLUE BIRD



CÓDIGO: 5006A
No. MAF: 5006A

PERCHA DEL. TRAS.
PHM



CÓDIGO: 5412B
No. MAF: 5412B

PERCHA DEL. TRAS.



CÓDIGO: PCH0006
No. MAF: PCH0006

TORNILLO "U"
3/4" x 4 1/16" x 16.00"



CÓDIGO: U6G160-B
No. MAF: U-6G160-B

PERNO



CÓDIGO: 13037
No. MAF: P-S500

BUJE BI-METALICO
1 1/2" x 1.260" x 4.00"
RNK



CÓDIGO: 06027BMR
No. MAF: RNK

BUJE BRONCE
1 1/2" x 1 1/4" x 4.00"
RNK



CÓDIGO: 06027R
No. MAF: RNK

NAVISTAR INTERNATIONAL

CAMIÓN

NAVISTAR INTERNATIONAL 4700

MODELOS 90-2005 ID598

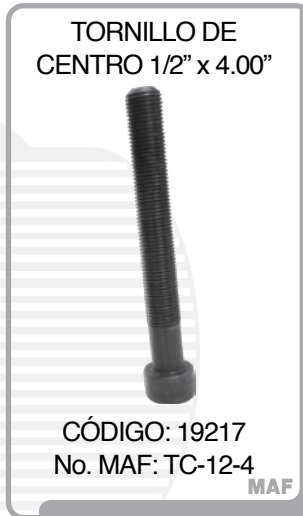

NAVISTAR INTERNATIONAL

CAMIÓN NAVISTAR INTERNATIONAL

2000 4000 Y 7000 MODELOS 89-2005

MUELLE Z 551133

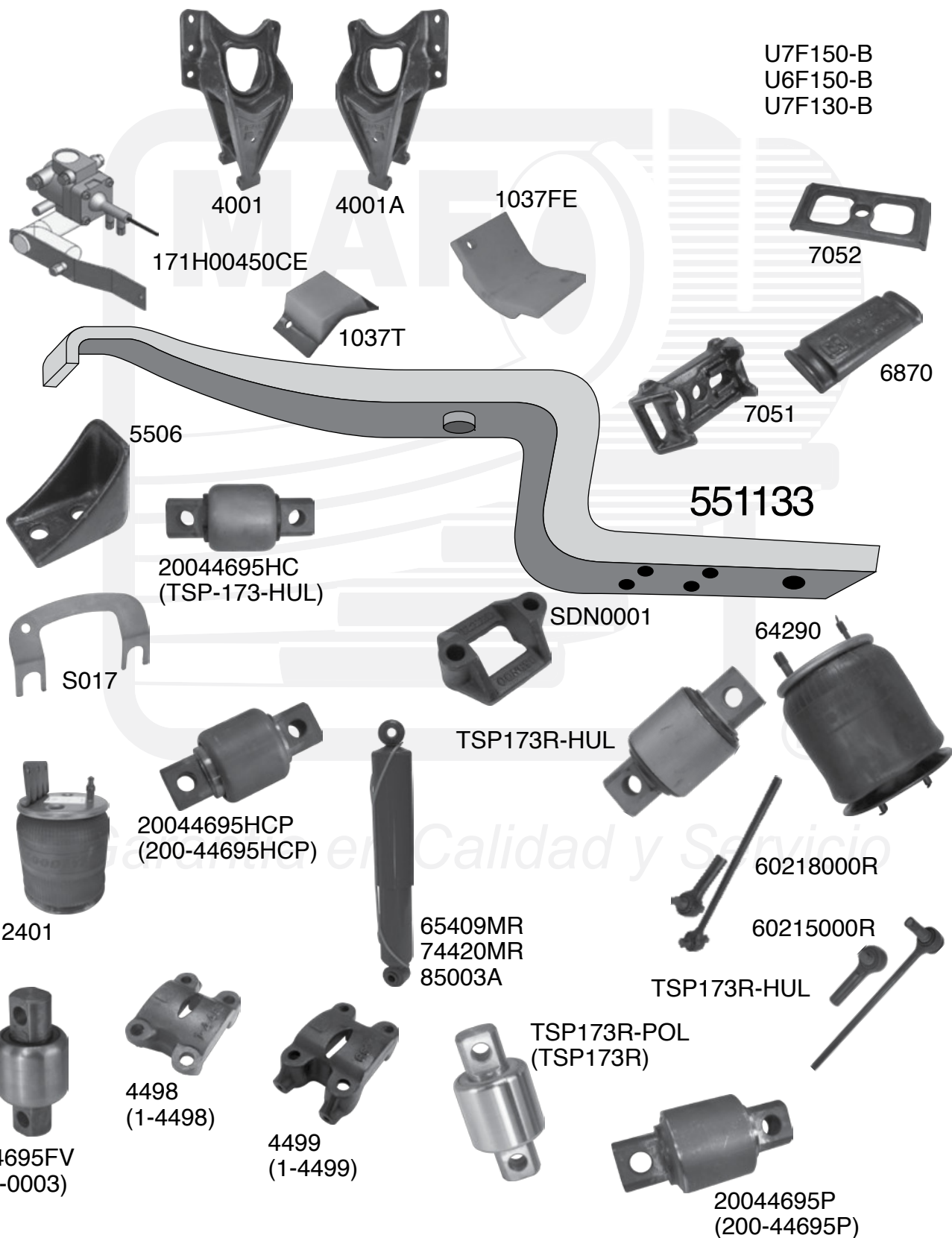

NAVISTAR INTERNATIONAL

CAMIÓN NAVISTAR INTERNATIONAL 2000 4000 Y 7000 MODELOS 89-2005 MUELLE Z 551133

CÓDIGO	No. MAF	DESCRIPCIÓN	CANTIDAD
4001A	4001A	PERCHA SUSP. DE AIRE TRAS. NAVISTAR QUINTA	2
4001	4001	PERCHA DEL. SUSP. MECÁNICA Y AIRE	2
171H00450CE	171H00450CE	VÁLVULA NIVELADORA HADLEY UNIVERSAL	2
1037FE	1037FE	SOPORTE P/MUELLE Z (PLACA)	2
1037T	1037	SOPORTE P/MUELLE Z	2
6870	6870	SOBRE MUELLE PARA SUSP. I.H.C. 3 1/2"	2
7052	7052	SEPARADOR PARA MUELLE DE 3 1/2"	4
7051	7051	CUÑA PARA MUELLE DE 3 1/2"	4
SDN0001	SDN0001	SOPORTE P/ BRAZO DE TORSIÓN DINA 881	2
5506	5506	TOPE AUXILIAR	2
U7F150-B	U-7F150-B	TORNILLO "U" 7/8" x 3 9/16" x 15.00"	2
U6F150-B	U-6F150-B	TORNILLO "U" 3/4" x 3 9/16" x 15.00"	2
U6F130-B	U-6F130-B	TORNILLO "U" 3/4" x 3 9/16" x 13.00"	2
1R12401	1R12401	1R12401=W013589371 BOLSA DE AIRE GOODYEAR	2
64290	64290	1R12401=W013589371 BOLSA AIRE CONTITECH	2
65409MR	65409	AMORTIGUADOR MONROE = 85003 MERITOR	2
74420MR	74420	AMORTIGUADOR MONROE = 85003 MERITOR	2
85003A	85003	AMORT. MERITOR=74420 Y/O 65409 MONROE k374-26	2
S017	S017	CANGREJO DE AJUSTE 1/16" x 4 3/8"	2
20044695FV	GND-0003	GRANADA KENWORTH T-800 ENCAPSULADA	2
20044695HC	TSP-173R-HUL	HEND. P/B TOR. IARSA-125 # 44695 ALTO CONF. HULE	2
20044695HCP	200-44695HCP	HEND. P/B TORSIÓN, TSP173R-POL ALTO CONF.	2
20044695P	200-44695P	HEND P/B TORSIÓN, TSP173R-POL	2
GND0003	GND-0003	GRANADA 2 3/4"	2
TSP173R-POL	TSP173R	GRANADA PARA BARRA TORSIÓN POLIURETANO	2
TSP173R-HUL	200-44695	GRANADA PARA BARRA TORSIÓN HULE	2
6021800R	60218-000	B/TORSIÓN TRANS. ESTILO ESPÁRRAGO	2
6021500R	60215-000	B/TORSIÓN TRANSV. CÓNICA ULTRA ROD. AJUS.	2
4498	1-4498	TAPA DIFERENCIAL IZQUIERDA NAVISTAR	2

NAVISTAR INTERNATIONAL
 CAMIÓN NAVISTAR INTERNATIONAL
 2000 4000 Y 7000 MODELOS 89-2005
 MUELLE Z 551133

CÓDIGO	No. MAF	DESCRIPCIÓN	CANTIDAD
4499	1-4499	TAPA DIFERENCIAL I.H.C 3 1/2" AIRE DERECHA NAV.	2
551133	55-1133	MUELLE TIPO "Z" 1.500" x 3 1/2" x 25 1/8" x 21 15/16"	2
ITA637LT	ITA-637LT	BRACKET IZQUIERDO .401" x 3 1/2" x 3 3/8" x 6 5/16"	2
ITA637RT	ITA-637RT	BRACKET DERECHO .401" x 3 1/2" x 3 3/8" x 6 5/16"	2

VER CATÁLOGO DE MUELLES 2011



Línea de frenos

Productos MAF para otras aplicaciones



Garantía e Calidad Servicio

Para mayor información consulte al ejecutivo de ventas

NAVISTAR INTERNATIONAL

CAMIÓN NAVISTAR INTERNATIONAL

2000 4000 Y 7000 MODELOS 89-2005

MUELLE Z 551133

PERCHA DEL QUINTA RUEDA



CÓDIGO: 4001A
No. MAF: 4001A

PERCHA SUPERIOR DELANTERA



CÓDIGO: 4001
No. MAF: 4001

VALVULA NIVELADORA HADLEY UNIVERSAL

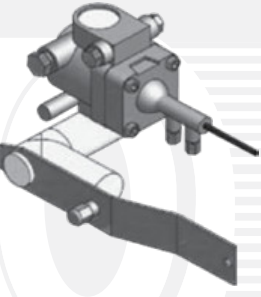

CÓDIGO: 171H00450CE
No. MAF: 171H00450CE

SOPORTE P/MUELLE "Z" (PLACA)



CÓDIGO: 1037FE
No. MAF: 1037FE

SOPORTE P/MUELLE "Z"



CÓDIGO: 1037T
No. MAF: 1037

SOBRE MUELLE P/ SUSPENSIÓN I.H.C 3 1/2"

CÓDIGO: 6870
No. MAF: 6870

SEPARADOR PARA MUELLE 3 1/2"

CÓDIGO: 7052
No. MAF: 7052

CUÑA PARA MUELLE DE 3 1/2"

CÓDIGO: 7051
No. MAF: 7051

SOPORTE P/BRAZO DE TORSIÓN



CÓDIGO: SDN0001
No. MAF: SDN0001

TOPE AUXILIAR



CÓDIGO: 5506
No. MAF: 5506

TORNILLO "U" 7/8" x 3 9/16" x 15.00"



CÓDIGO: U7F150-B
No. MAF: U-7F150-B

TORNILLO "U" 3/4" x 3 9/16" x 15.00"



CÓDIGO: U6F150-B
No. MAF: U-6F150-B

NAVISTAR INTERNATIONAL
CAMIÓN NAVISTAR INTERNATIONAL
2000 4000 Y 7000 MODELOS 89-2005
MUELLE Z 551133

<p>TORNILLO "U" 3/4" x 3 9/16" x 13.00"</p>  <p>CÓDIGO: U6F130-B No. MAF: U6F130-B</p>	<p>BOLSA DE AIRE GOODYEAR.</p>  <p>CÓDIGO: 1R12401 No. MAF: 1R12401</p>	<p>BOLSA DE AIRE CONTITECH</p>  <p>CÓDIGO: 64290 No. MAF: 64290</p>	<p>AMORT. MONROE = 85003 MERITOR</p>  <p>CÓDIGO: 65409MR No. MAF: 65409</p>
<p>AMORT. MONROE = 85003 MERITOR</p>  <p>CÓDIGO: 74420MR No. MAF: 74420</p>	<p>AMORT. MERITOR = 74420 Y/O 65409</p>  <p>CÓDIGO: 85003A No. MAF: 85003</p>	<p>CANGREJO DE AJUSTE</p>  <p>CÓDIGO: S017 No. MAF: S017</p>	<p>GRANADA KENWORTH T-800 ENCAPSULADA</p>  <p>CÓDIGO: 20044695FV No. MAF: GND-0003</p>
<p>P/B TORSIÓN IARSA 125 # 44695 ALTO CONF. HULE</p>  <p>CÓDIGO: 20044695HC No. MAF: TSP-173R-HUL</p>	<p>P/B TORSIÓN TSP173-POL ALTO CONF.</p>  <p>CÓDIGO: 20044695HCP No. MAF: 200-44695HCP</p>	<p>P/B TORSIÓN TSP173R-POL</p>  <p>CÓDIGO: 20044695P No. MAF: 200-44695P</p>	<p>GRANADA PARA BARRA DE TORSIÓN PLIURETANO</p>  <p>CÓDIGO: TSP173R-POL No. MAF: TSP173</p>

NAVISTAR INTERNATIONAL

CAMIÓN NAVISTAR INTERNATIONAL

2000 4000 Y 7000 MODELOS 89-2005

MUELLE Z 551133

GRANADA PARA
BARRA DE TORSIÓN
HULE



CÓDIGO: TSP173R-HUL
No. MAF: 200-44695

MAF

B/TORSIÓN TRANS.
ESTILO ESPARRAGO



CÓDIGO: 6021800R
No. MAF: 60218-000

MAF

B/TORSIÓN TRANS.
CÓNICA ULTRA ROD.
AJUSTADA

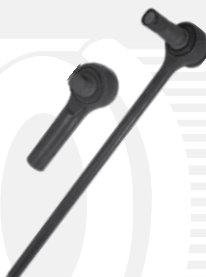

CÓDIGO: 6021500R
No. MAF: 60215-000

MAF

TAPA DIFERENCIAL
IZQUIERDA

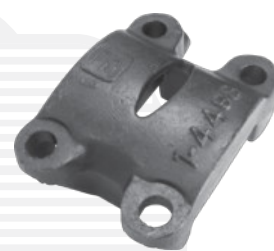

CÓDIGO: 4498
No. MAF: 1-4498

MAF

TAPA DIFERENCIAL
DERECHA



CÓDIGO: 4499
No. MAF: 1-4499

MAF

Garantía en Calidad y Servicio

NAVISTAR INTERNATIONAL
 TRACTO CAMIÓN NAVISTAR
 INTERNATIONAL 9200
 MODELOS 89-2000 551176

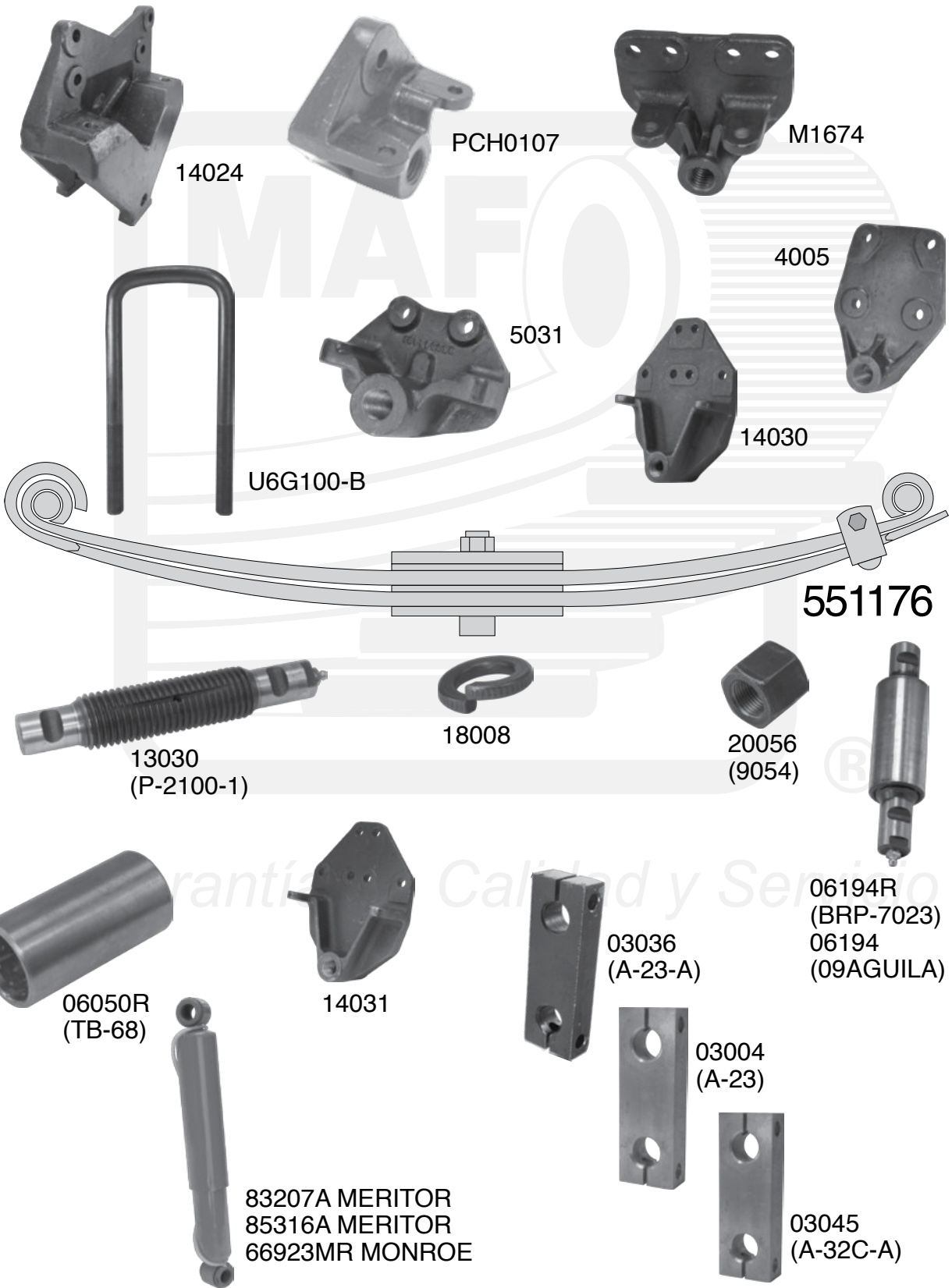

NAVISTAR INTERNATIONAL

TRACTO CAMIÓN NAVISTAR INTERNATIONAL 9200 MODELOS 89-2000 551176

CÓDIGO	No. MAF	DESCRIPCIÓN	CANTIDAD
14024	8513	PERCHA DEL. DEL. DINA 9400 PHM 4016 FUNDICIÓN	2
M1674	M1674	PERCHA ROSCADA DINA 9400 PHM4028 FUNDICIÓN	2
5031	5031	PERCHA TRAS. DEL. ROSC. 1 3/8" NAVISTAR	2
PCH0107	PCH0107	PERCHA DELANTERA TRASERA	2
4005	4005	PERCHA ROSCADA INTERNATIONAL PHM 4028 FUND.	2
14030	8514	PERCHA DEL. TRAS. DINA 9400 PHM 5021 FUND.	2
14031	8514-A	PERCHA DEL. TRAS. DINA 9400 IMO5414A FUND.	4
U6G100-B	U-6G100-B	TORNILLO "U" 3/4" x 4 1/16" x 10.00"	8
13030	P-2100-1	P-2100-1 PERNO	4
06050R	TB-68	BUJE ROSCADO TB-26= TB-68	4
06194R	06194R	CTO. PER./BUJE P-2100-1/TB-68)BPR7023	2
83207A	83207	AMORTIGUADOR MERITOR = 66886 MONROE	2
85316A	85316	AMORTIGUADOR MERITOR = 65107 MONROE	2
66923MR	66923	AMORTIGUADOR MONROE = 83102 MERITOR	2
03036	A-23-A	ALBARDÓN 9400	4
03004	A-23	ALBARDÓN 9400	4
03045	A-32C-A	ALBARDÓN ALUMINIO	4
20056	9054	TUERCA FINA ALTA 3/4" - °8	1
18008	AR-34	RONDANA DE PRESIÓN 3/4"	8
551176F	55-1176F	MUELLE PARABÓLICA 2 HOJAS 4" x .999" x 29" x 29"	2

VER CATÁLOGO DE MUELLES MAF 2011

NAVISTAR INTERNATIONAL

TRACTO CAMIÓN NAVISTAR INTERNATIONAL 9200

MODELOS 89-2000 55-1176

PERCHA DEL. DEL.
DINA 9400PHM 4016
FUND.



CÓDIGO: 14024
No. MAF: 8513

MAF

PERCHA DEL. TRAS.
ROSCA DE 1 3/8



CÓDIGO: 5031
No. MAF: 5031

MAF

PERCHA DEL. TRAS.
P/COL. ROSC. INTER C1



CÓDIGO: PCH0107
No. MAF: PCH0107

MAF

PERCHA INTER ROSC.
1 3/8 9200/9400 FUND.



CÓDIGO: 4005
No. MAF: 4005

MAF

PERCHA DEL. TRAS.
DINA 9400 PHM 5021
FUND.



CÓDIGO: 14030
No. MAF: 8514

MAF

TORNILLO "U"
3/4" x 4 1/16" x 10.00"



CÓDIGO: U6G100-B
No. MAF: U-6G100-B

MAF

AMORT. MERITOR =
83102 MERITOR



CÓDIGO: 66923MR
No. MAF: 66923

MAF

AMORT. MERITOR =
66886 MONROE



CÓDIGO: 83207A
No. MAF: 83207

MAF

PERNO



CÓDIGO: 13030
No. MAF: P-2100-1

MAF

BUJE ROSCADO
TB-26 = TB-68



CÓDIGO: 06050R
No. MAF: TB-68

MAF

CONJUNTO PER/BUJE
(P-2100-1/TB-68)



CÓDIGO: 06194R
No. MAF: BPR-7032

MAF

AMORT. MERITOR =
65107 MONROE



CÓDIGO: 85316A
No. MAF: 85316

MAF

NAVISTAR INTERNATIONAL

TRACTO CAMIÓN NAVISTAR INTERNATIONAL 9200 MODELOS 89-2000 55-1176

TUERCA FINA ALTA
3/4" 98



CÓDIGO: 20056
No. MAF: 9054

MAF

RONDANA DE
PRESIÓN 3/4"



CÓDIGO: 18008
No. MAF: AR-34

MAF

ALBARDÓN
ALUMINIO



CÓDIGO: 03036
No. MAF: A-23-A

MAF

ALBARDÓN
PLACA



CÓDIGO: 03004
No. MAF: A-23

MAF

ALBARDÓN
ALUMINIO



CÓDIGO: 03045
No. MAF: A-32C-A

MAF

PERCHA ROSCADA
DINA 9400
PHM4028 FUND.



CÓDIGO: M1674
No. MAF: M1674

MAF

PERCHA DEL. TRANS.
DINA 9400



CÓDIGO: 14031
No. MAF: 8514-A

MAF

Garantía en Calidad y Servicio

NAVISTAR INTERNATIONAL
CAMIÓN NAVISTAR INTERNATIONAL
SERIE 800 MODELOS 90-2005
MUELLE PARABÓLICA 551326

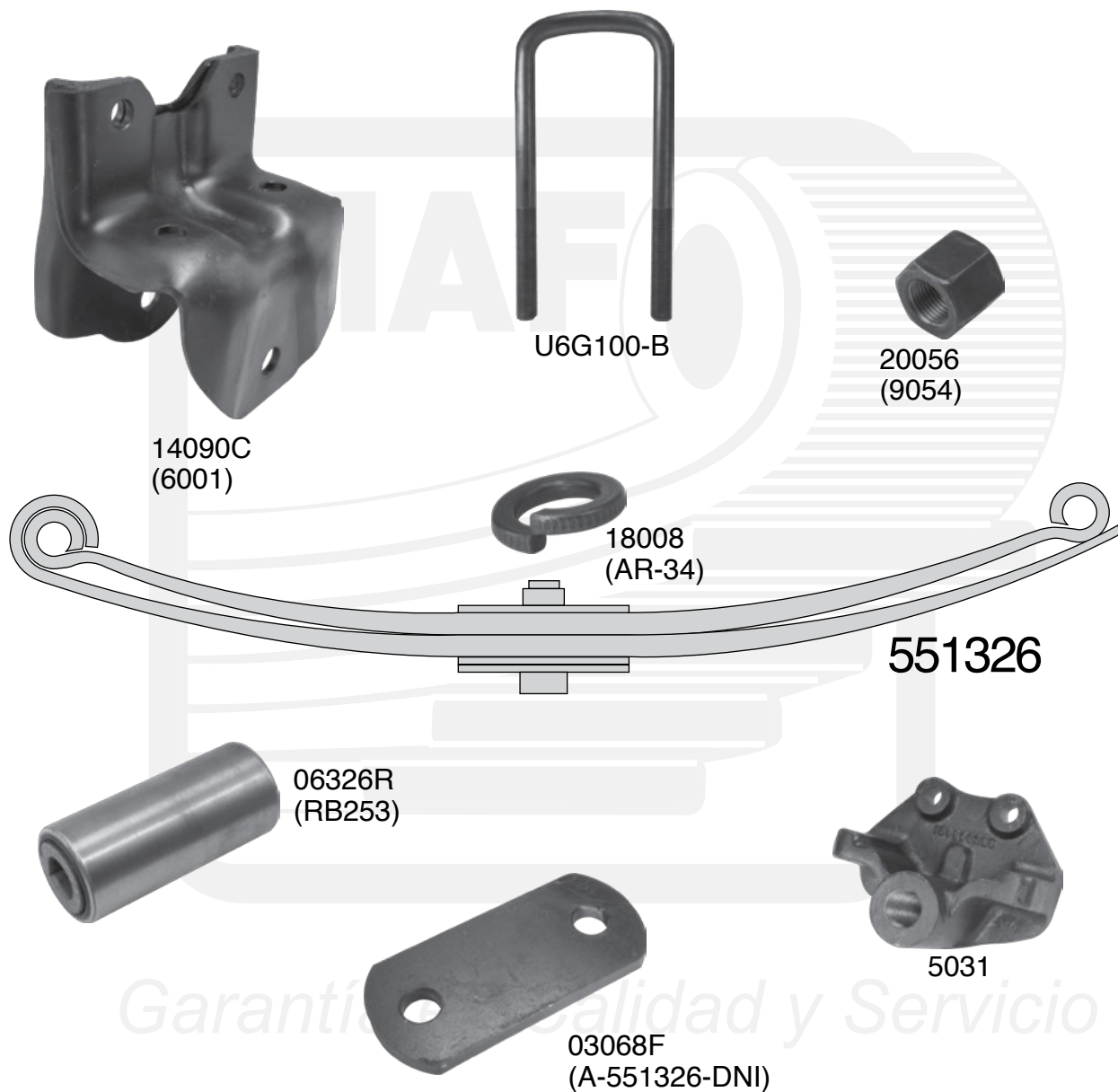

NAVISTAR INTERNATIONAL

CAMIÓN NAVISTAR INTERNATIONAL

SERIE 800 MODELOS 90-2005

MUELLE PARABÓLICA 551326

CÓDIGO	No. MAF	DESCRIPCIÓN	CANTIDAD
03068F	A-551326-DNI	ALBARDÓN	4
06326R	RB253	BUJE FIERRO Y HULE	2
5031	5031	PERCHA TRAS. DEL. ROSC.1 3/8"	2
14090C	6001	PERCHA DEL. DEL.	2
U6G100-B	U-6G100-B	TORNILLO "U" 3/4" x 4 1/16" x 10.00"	4
20056	9054	TUERCA FINA ALTA 3/4" °8	8
18008	AR-34	RONDANA DE PRESIÓN 3/4"	8
06326R	RB-253	BUJE PARA MUELLE RB-253 EXT 1 13/16 INT 3/4 LG 4 1	2
551326F	55-1326F	MUELLE PARABÓLICA DE 2 HOJAS	2
		4" x .815" x 25" x 29" BUJES	

PARA MAYOR DETALLE DE ESPESORES ESPECIALES
VER CATÁLOGO DE MUELLES 2011



Válvula niveladora

Productos MAF para otras aplicaciones

Garantía de Calidad y Servicio

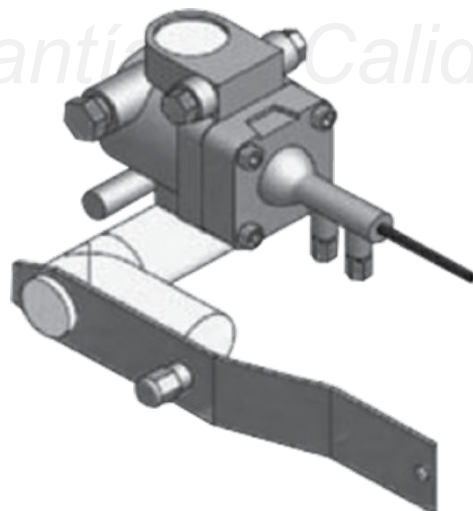

Para mayor información consulte al ejecutivo de ventas

NAVISTAR INTERNATIONAL
 CAMIÓN NAVISTAR INTERNATIONAL
 SERIE 800 MODELOS 90-2005
 MUELLE PARABÓLICA 551326

ALBARDÓN



CÓDIGO: 03068F
 No. MAF: A-551326-DNI
 MAF

BUJE FIERRO
 Y HULE



CÓDIGO: 06326R
 No. MAF: RB253
 MAF

PERCHA DEL. TRAS.
 DEL. ROSC 1 3/8"



CÓDIGO: 5031
 No. MAF: 5031
 MAF

PERCHA DEL. DEL.



CÓDIGO: 14090C
 No. MAF: 6001
 MAF

TORNILLO "U"
 3/4" x 4 1/16" x 10.00"

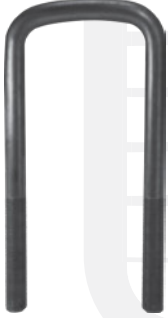

CÓDIGO: U6G100-B
 No. MAF: U-6G100-B
 MAF

TUERCA FINA ALTA
 3/4" 8



CÓDIGO: 20056
 No. MAF: 9054
 MAF

RONDANA DE
 PRESIÓN 3/4"



CÓDIGO: 18008
 No. MAF: AR-34
 MAF

Garantía en Calidad y Servicio

NAVISTAR INTERNATIONAL

NAVISTAR INTERNATIONAL

SUSPENSIÓN NEUMÁTICA

MUELLE "Z" 55067

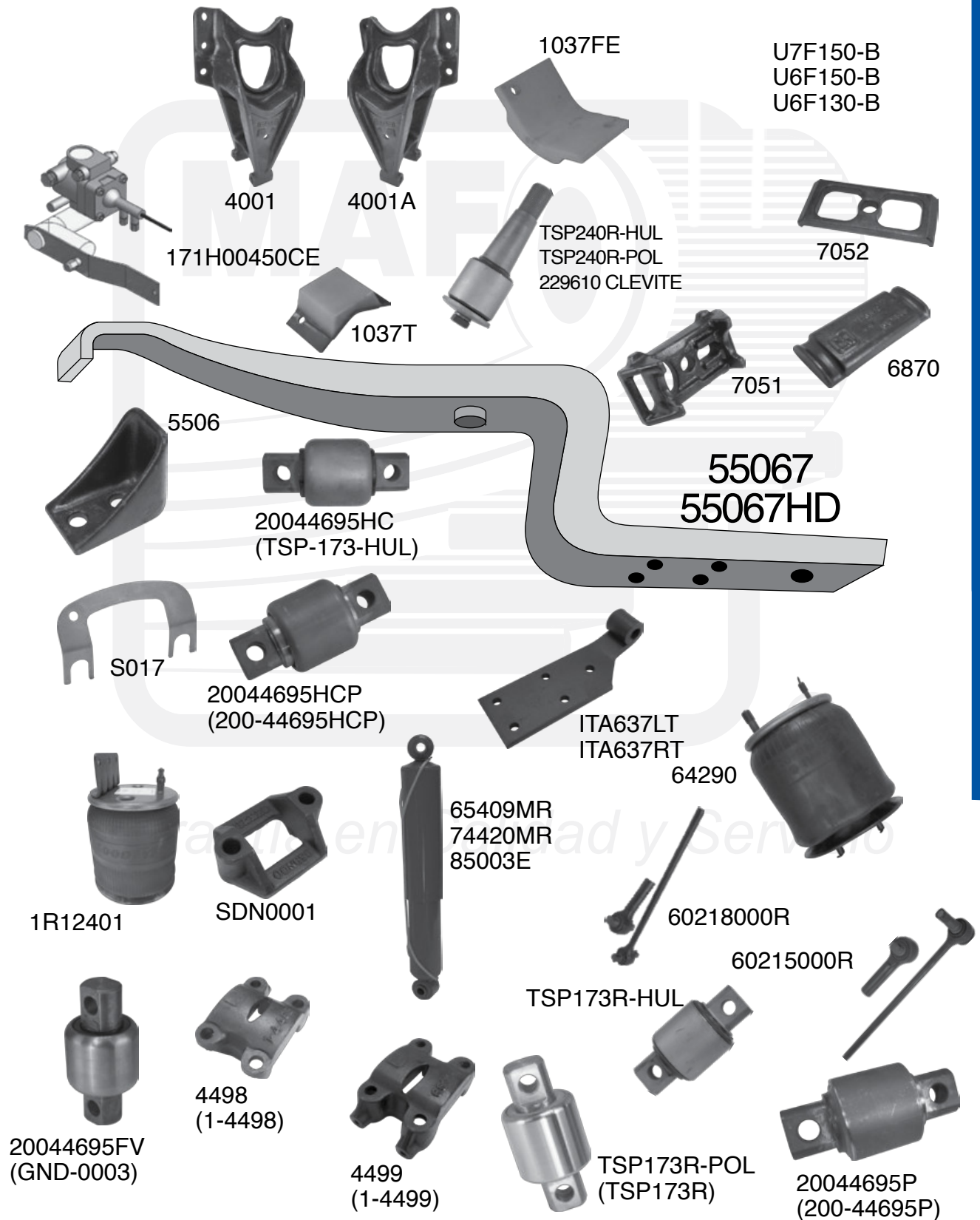

NAVISTAR INTERNATIONAL

NAVISTAR INTERNATIONAL

SUSPENSIÓN NEUMÁTICA

MUELLE "Z" 55067

CÓDIGO	No. MAF	DESCRIPCIÓN	CANTIDAD
4001A	4001A	PERCHA SUSP. DE AIRE TRA. NAVISTAR QUINTA	2
4001	4001	PERCHA DEL. SUSP. MECÁNICA Y AIRE	2
171H00450CE	171H00450CE	VÁLVULA NIVELADORA HADLEY UNIVERSAL	2
1037FE	1037FE	SOPORTE P/MUELLE "Z" (PLACA)	2
1037T	1037	SOPORTE P/MUELLE "Z"	2
6870	6870	SOBRE MUELLE P/SUSPENSIÓN I.H.C. 3 1/2"	2
7052	7052	SEPARADOR PARA MUELLE DE 3 1/2"	4
7051	7051	CUÑA PARA MUELLE DE 3 1/2"	4
SDN0001	SDN0001	SOPORTE P/ BRAZO DE TORSIÓN DINA 881	2
5506	5506	TOPE AUXILIAR	2
U7F150-B	U-7F150-B	TORNILLO "U" 7/8" x 3 9/16" x 15.00"	2
U6F150-B	U-6F150-B	TORNILLO "U" 3/4" x 3 9/16" x 15.00"	2
U6F130-B	U-6F130-B	TORNILLO "U" 3/4" x 3 9/16" x 13.00"	2
1R12401	1R12401	1R12401=W013589371 BOLSA DE AIRE GOODYEAR	2
64290	64290	1R12401=W013589371 BOLSA AIRE CONTITECH	2
65409MR	65409	AMORTIGUADOR MONROE = 85003 MERITOR	2
74420MR	74420	AMORTIGUADOR MONROE = 85003 MERITOR	2
85003A	85003	AMORT MERITOR=74420 Y/O 65409 MONROE k374-26	2
S017	S017	CANGREJO DE AJUSTE 1/16" x 4 3/8"	2
20044695FV	GND-0003	GRANADA KENWORTH T-800 ENCAP. HEND. P/B	2
20044695HC	TSP-173R-HUL	TORSIÓN IARSA-125 # 44695 ALTO CONF. HULE	2
20044695HCP	200-44695HCP	HEND. P/B TORSIÓN, TSP173R-POL. ALTO CONF.	2
20044695P	200-44695P	HEND. P/B TORSIÓN, TSP173R-POL.	2
GND0003	GND-0003	GRANADA 2 3/4"	2
TSP173R-POL	TSP173R	GRANADA PARA BARRA TORSIÓN POLIURETANO	2
TSP173R-HUL	200-44695	GRANADA PARA BARRA TORSIÓN HULE	2
TSP240R-HUL	200-44697	GRANADA CÓNICA	2
6021800R	60218-000	B/TORSIÓN TRANS. ESTILO ESPÁRRAGO	2
6021500R	60215-000	B/TORSIÓN TRANSV. CÓNICA ULTRA ROD AJUS.	2

NAVISTAR INTERNATIONAL

NAVISTAR INTERNATIONAL

SUSPENSIÓN NEUMÁTICA

MUELLE "Z" 55067

CÓDIGO	No. MAF	DESCRIPCIÓN	CANTIDAD
4498	1-4498	TAPA DIFERENCIAL IZQUIERDA NAVISTAR	2
4499	1-4499	TAPA DIFERENCIAL I.H.C 3 1/2 AIRE DERECHA NAV	2
ITA637LT	ITA-637LT	BRACKET IZQUIERDO 3 1/2" x .401" x 3 3/8" x 6 5/16"	2
ITA637RT	ITA-637RT	BRACKET DERECHO 3 1/2" x .401" x 3 3/8" x 6 5/16"	2
55067	55-067	MUELLE TIPO Z 3 1/2" x 1.315" x 25 1/8" x 18 15/16"	2
55067HD	55-067HD	MUELLE TIPO Z 3 1/2" x 1.500" x 25 1/8" x 18 15/16"	2

VER CATÁLOGO DE MUELLES 2011



Kit de levante

Productos MAF para otras aplicaciones

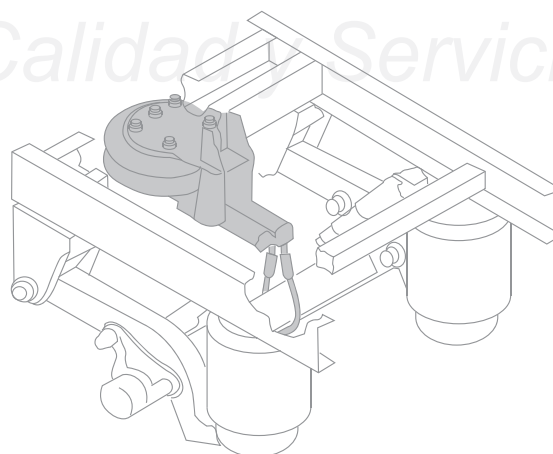

NAVISTAR INTERNATIONAL

NAVISTAR INTERNATIONAL

SUSPENSIÓN NEUMÁTICA

MUELLE "Z" 55067

PERCHA SUSP. DE AIRE
TRA. NAVISTAR QUINTA



CÓDIGO: 4001A
No. MAF: 4001A

MAF

PERCHA DEL. SUSP.
MECÁNICA Y AIRE



CÓDIGO: 4001
No. MAF: 4001

MAF

VÁLVULA NIVELADORA
HADLEY UNIVERSAL

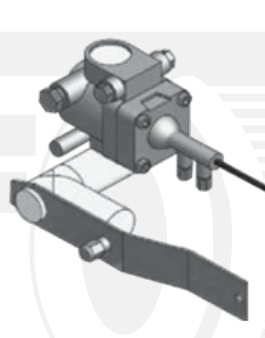

CÓDIGO: 171H00450CE
No. MAF: 171H00450CE

MAF

SOPORTE P/MUELLE
"Z" (PLACA)



CÓDIGO: 1037FE
No. MAF: 1037FE

MAF

SOPORTE P/MUELLE
"Z"



CÓDIGO: 1037T
No. MAF: 1037

MAF

SOBRE MUELLE
P/SUSP. I-H.C. 3 1/2"



CÓDIGO: 6870
No. MAF: 6870

MAF

SEPARADORA
PARA MUELLE 3 1/2"



CÓDIGO: 7052
No. MAF: 7052

MAF

CUÑA PARA
MUELLE DE 3 1/2"



CÓDIGO: 7051
No. MAF: 7051

MAF

SOPORTE P/BRAZO
DE TORSIÓN



CÓDIGO: SDN0001
No. MAF: SDN0001

MAF

TOPE AUXILIAR



CÓDIGO: 5506
No. MAF: 5506

MAF

TORNILLO "U"
7/8 x 3 9/16 x 15.00



CÓDIGO: U7F150-B
No. MAF: U-7F150-B

MAF

TORNILLO "U"
3/4 x 3 9/16" x 15.00



CÓDIGO: U6F150-B
No. MAF: U6F150-B

MAF

NAVISTAR INTERNATIONAL

NAVISTAR INTERNATIONAL

SUSPENSIÓN NEUMÁTICA

MUELLE "Z" 55067



NAVISTAR INTERNATIONAL

NAVISTAR INTERNATIONAL

SUSPENSIÓN NEUMÁTICA

MUELLE "Z" 55067

GRANADA P/BARRA
TORSIÓN HULE



CÓDIGO: TSP173R-HUL
No. MAF: 200-44695

MAF

B/TORSIÓN TRANS.
ESTILO ESPARRAGO



CÓDIGO: 6021800R
No. MAF: 60218-000

MAF

B/TORSIÓN TRANSV.
CÓNICA ULTRA ROD.
AJUS.

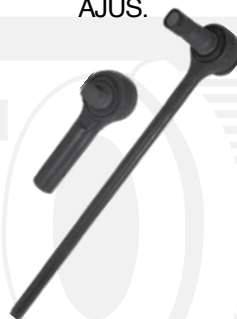

CÓDIGO: 6021500R
No. MAF: 60215-000

MAF

TAPA DIFERENCIAL
IZQUIERDA

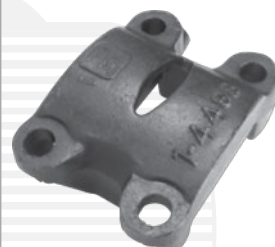

CÓDIGO: 4498
No. MAF: 1-4498

MAF

TAPA DIFERENCIAL
DERECHA



CÓDIGO: 4499
No. MAF: 1-4499

MAF

GRANADA BARRA
TORSIÓN



TSP240R-HUL
TSP240R-POL
229610 CLEVITE

MAF

BRACKET IZQUIERDO



CÓDIGO: ITA637LT
No. MAF: ITA-637LT

MAF

BRACKET DERECHO



CÓDIGO: ITA637RT
No. MAF: ITA-637RT

MAF

Garantía en Calidad y Servicio

NAVISTAR

MUELLE DELANTERA COMPLETA MODELO 2003 NAVISTAR 9000 PARABOLICA 55964F

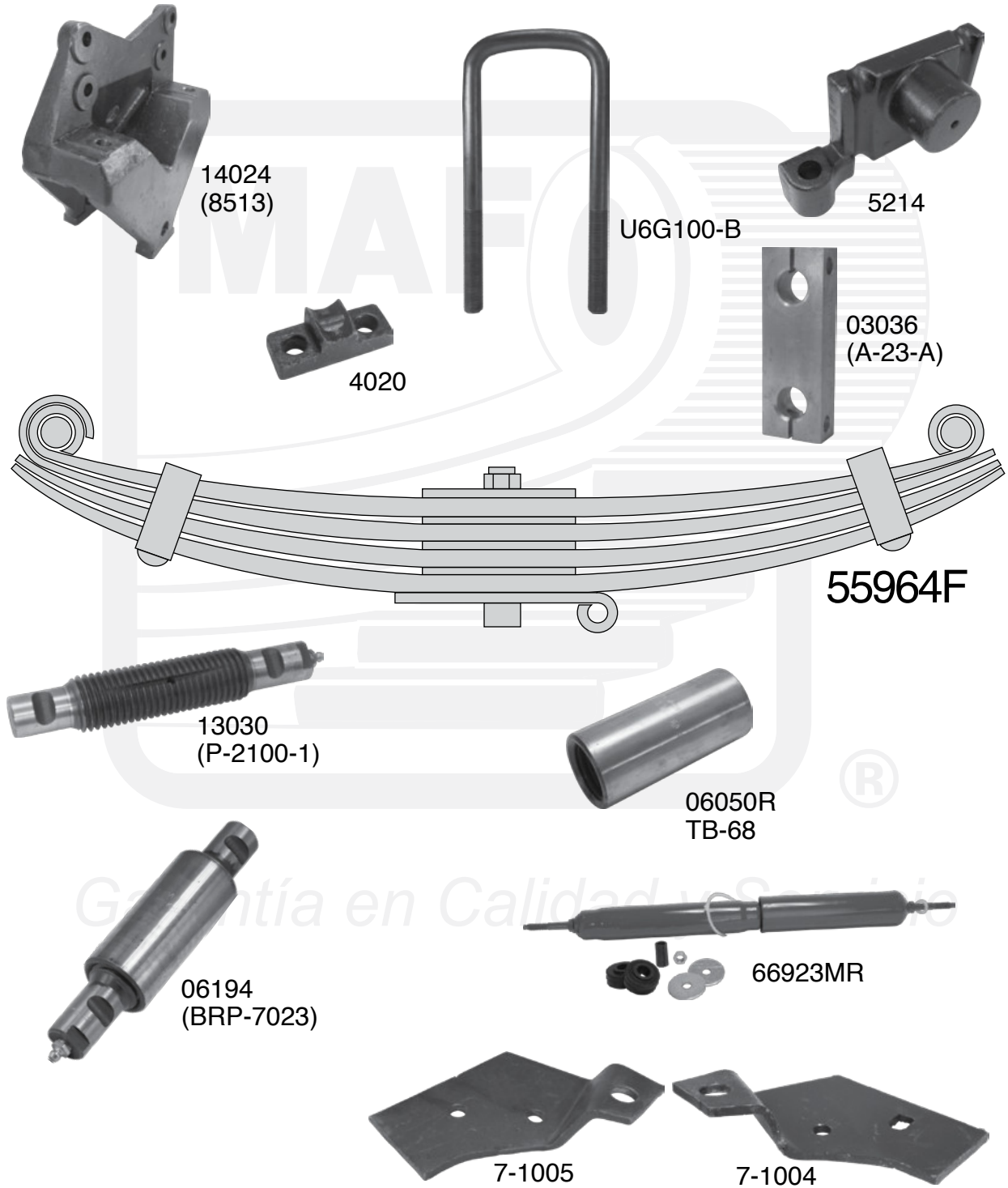

NAVISTAR

MUELLE DELANTERA COMPLETA MODELO 2003 NAVISTAR 9000 PARABOLICA 55964F

CÓDIGO	No. MAF	DESCRIPCIÓN	CANTIDAD
14024	8513	8513 PERCHA DEL. DEL. DINA 9400 PHM 4016 FUNDICIÓN	2
13030	P-2100-1	P-2100-1 PERNO (AGUILA O T-400)	4
5214	5214	SOBRE MUELLE DEL.4" C/SOPORTE DE AMORTIGUADOR	2
03036	A-23-A	A-23-A ALBARDÓN DINA S-600	4
06194R	BPR-7023	CTO. PER./BUJE DINA AGUILA (P-2100-1/TB-68)BPR7023	2
66923MR	66923	66923 AMORT. MONROE = 83102 MERITOR	2
7-1004	7-1004	SOP. AMORT INFERIOR P/RABÓN DEL MUELLE DE 4" IZQ	2
7-1005	7-1005	SOP. AMORT INFERIOR P/RABÓN DEL MLLE DE 4" DER.	2
4020	4020	SEGURO INTER. P/PERCHAS	4
U6G100-B	U-6G100-B	TORNILLO "U" 3/4" x 4 1/16" x 10.00"	8
55-964F	55-964F	PARABOLICA 4.00" x .788" x 25.0" x 29.00"	2

VER CATÁLOGO DE MUELLES MAF 2011



Acordeones o Bolsters

Productos MAF para otras aplicaciones

Garantía en Calidad y Servicio



Para mayor información consulte al ejecutivo de ventas

NAVISTAR

MUELLE DELANTERA COMPLETA MODELO 2003 NAVISTAR 9000 PARABÓLICA 55964F

<p>PERCHA DEL. DEL. DINA 9400</p>  <p>CÓDIGO: 14024 No. MAF: 8513</p> <p>MAF</p>	<p>SOPORTE DE AMORT. DEL. SUP.</p>  <p>CÓDIGO: 13030 No. MAF: P-2100-1</p> <p>MAF</p>	<p>SOBRE MUELLE DEL, 4" C/SOPORTE DE AMORTIGUADOR.</p>  <p>CÓDIGO: 5214 No. MAF: 5214</p> <p>MAF</p>	<p>A-23 ALBARDÓN DINA.</p>  <p>CÓDIGO: 03036 No. MAF: A-23-A</p> <p>MAF</p>
<p>CTO. PER./BUJE DINA AGUILA (P-2100-1/TB-68) BPR7023</p>  <p>CÓDIGO: 06194R No. MAF: BPR-7023</p> <p>MAF</p>	<p>66923 AMORT. MONROE = 83102 MERITOR</p>  <p>CÓDIGO: 66923MR No. MAF: 66923</p> <p>MAF</p>	<p>SOP. AMORT. INFERIOR P/RABÓN DEL. MUELLE DE 4" IZQ</p>  <p>CÓDIGO: 7-1004 No. MAF: 7-1004</p> <p>MAF</p>	<p>SOP. AMORT. INFERIOR P/RABÓN DEL. MUELLE DE 4" DER.</p>  <p>CÓDIGO: 7-1005 No. MAF: 7-1005</p> <p>MAF</p>
<p>TORNILLO "U" 3/4" x 4 1/16" x 10.00"</p>  <p>CÓDIGO: U6G100-B No. MAF: U-6G100-B</p> <p>MAF</p>	<p>SEGURO INTERNO P/PERCHAS</p>  <p>CÓDIGO: 4020 No. MAF: 4020</p> <p>MAF</p>	<p>Calidad y Servicio</p>	

FAMSA

TRACTO-CAMIÓN
S-2500 FAD2500

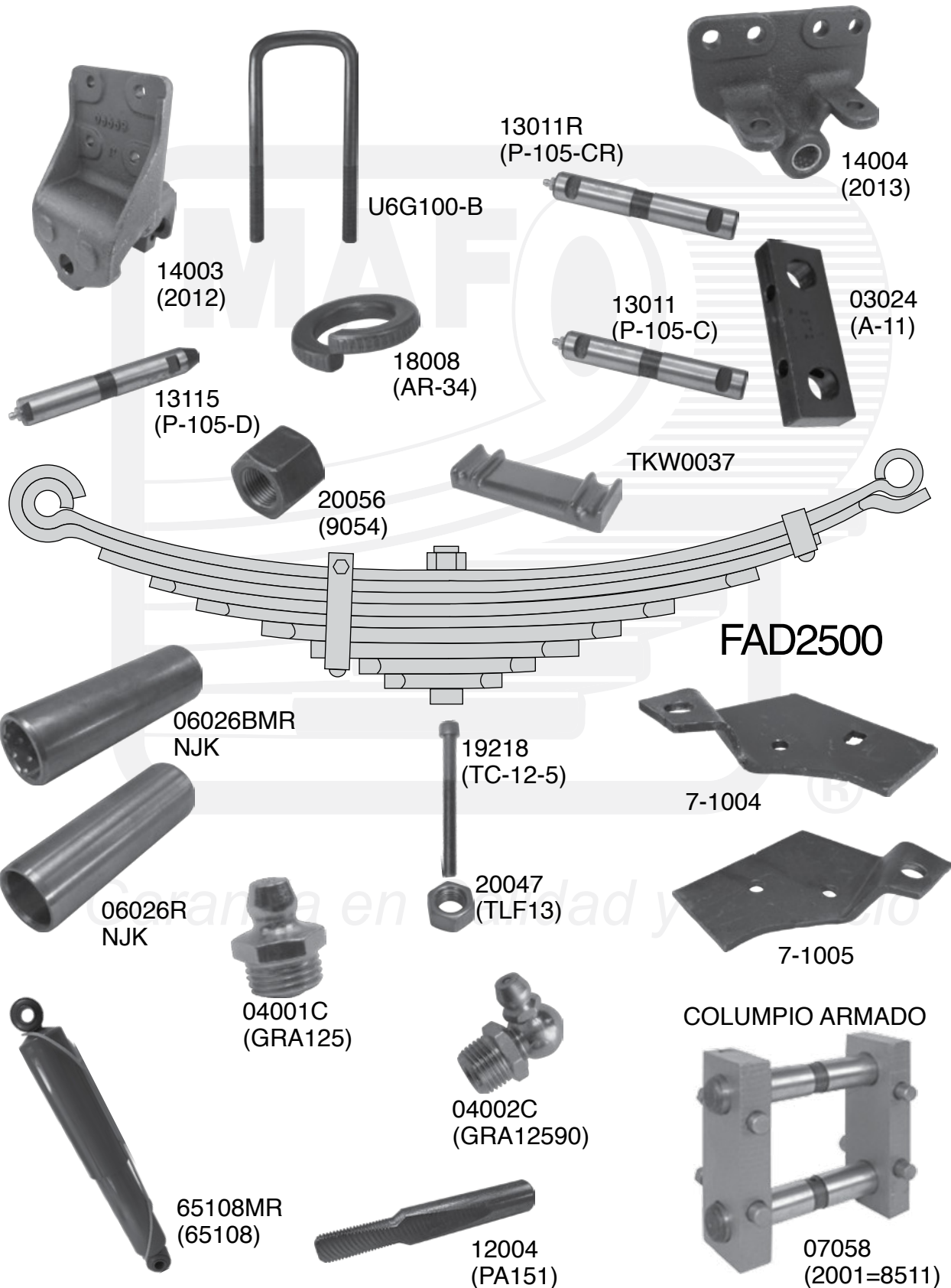

TRACTO-CAMIÓN
S-2500 FAD2500

CÓDIGO	No. MAF	DESCRIPCIÓN	CANTIDAD
14003	2012	PERCHA # 1 PERNO 1"	2
14004	2013	PERCHA # 2 PERNO 1"	2
12004	PA151	PERNO PASADOR	8
03024	A-11	ALBARDÓN F-190 / 251 / 2500	4
13011	P-105-C	PERNO 1" x 6 5/16" seguro cuadrado	2
13011R	P-105-CR	PERNO 1" x 6 5/16" seguro redondo	2
13115	P 105-D	PERNO 105D 7/8" x 7" tipo lápiz	2
U6G100-B	U6G100-B	TORNILLO "U" 3/4" x 4 1/16" x 10"	4
04001C	GRA125	GRASERA RECTA NPT 1/8"	4
04002C	GRA12590	GRASERA DE 1/8 NPT 90°	4
06026R	NJK	BUJE DE BRONCE NJK 11/4" x 1" x 4"	4
06026BMR	NJK	BUJE BI-METÁLICO NJK 1 1/4" x 1.010" x 4"	4
20047	TLF13	TUERCA FINA DE 1/2" °2	2
19218	TC-12-5	TORNILLO DE CENTRO 1/2" x 5"	2
7-1004	7-1004	SOPORTE AMORTIGUADOR IZQUIERDO	1
7-1005	7-1005	SOPORTE AMORTIGUADOR DERECHO	1
TKW0037	TKW0037	SOBRE CAMA DE MUELLE	2
20056	9054	TUERCA FINA ALTA 3/4" °8	8
18008	AR-34	RONDANA DE PRESIÓN 3/4"	8
65108MR	65108	AMORTIGUADOR MERITOR	2
07058	2001-8511	COLUMPIO ARMADO, CONJUNTO CON:	1
		2 PERNOS PA 105 C (13011)	
		2 ALBARDONES A-11 (03024)	
		4 PERNOS PA151 (12004)	
		4 TUERCAS TLF09 (20004)	
		4 RONDANAS DE PRESIÓN AR38 (18003)	
FAD2500	FAD-2500	MUELLE DE 9 HOJAS	2
		4" x 0.401" x 25" x 29" DE ROLEO 1.240" -1.248"	
		HOJAS DE REFUERZO	2
		FAD2500-03R 4" x 0.401" x 22 3/4" x 26 1/2"	2
		FAD2500-04R 4" x 0.401" x 20 1/8" x 23 3/4"	

FAMSA

TRACTO-CAMIÓN S-2500 FAD2500

PERCHA FAMSA DEL.
DEL. PERNO 1"



CÓDIGO: 14003
No. MAF: 2012

MAF

PERCHA FAMSA DEL.
TRAS. PERNO 1"



CÓDIGO: 14004
No. MAF: 2013

MAF

PERNO PASADOR
CUADRADO.



CÓDIGO: 12004
No. MAF: PA151

MAF

ALBARDÓN
5 1/2" x 2" x .800"



CÓDIGO: 03024
No. MAF: A-11

MAF

PERNO 1" X 6 5/8"
SEGURO CUADRADO



CÓDIGO: 13011
No. MAF: P-105-C

MAF

PERNO 1" X 6 5/8"
SEGURO REDONDO



CÓDIGO: 13011R
No. MAF: P-105-CR

MAF

PERNO 1" X 7"
SEGURO TIPO LÁPIZ



CÓDIGO: 130115
No. MAF: P-105D

MAF

TORNILLO "U"
3/4" x 4 1/16" x 10.00"



CÓDIGO: U6G100-B
No. MAF: U-6G100-B

MAF

GRASERA DE 1/8
NPT 90°



CÓDIGO: 04002C
No. MAF: GRA12590

MAF

GRASERA RECTA
NPT 1/8"



CÓDIGO: 04001C
No. MAF: GRA125

MAF

BUJE BRONCE
1 1/4" x 1.00" x 4.00"



CÓDIGO: 06026R
No. MAF: NJK

MAF

BUJE BI-METÁLICO
1 1/4" x 1.010 x 4.00"
NJK



CÓDIGO: 06026BR
No. MAF: NJJK

MAF

FAMSA

TRACTO-CAMIÓN
S-2500 FAD2500

TURCA UNF °2



CÓDIGO: 20047
No. MAF: TLF13

TORNILLO DE CENTRO
1/2" x 5.00



CÓDIGO: 19218
No. MAF: TC-12-5

SOPORTE
AMORTIGUADOR IZQ.



CÓDIGO: 7-1004
No. MAF: 7-1004

SOPORTE
AMORTIGUADOR DER.



CÓDIGO: 7-1005
No. MAF: 7-1005

SOBRE CAMA DE
MUELLE



CÓDIGO: TKW0037
No. MAF: TKW0037

TUERCA FINA ALTA
3/4" °8



CÓDIGO: 20056
No. MAF: 9054

RONDANA DE
PRESIÓN 3/4"



CÓDIGO: 18008
No. MAF: AR-34

COLUMPIO ARMADO



CÓDIGO: 07058
No. MAF: 2001=8511

AMORTIGUADOR
MERITOR



CÓDIGO: 65108MR
No. MAF: 65108

Garantía en Calidad y Servicio

FAMSA

FAMSA S-1900
SUSPENSIÓN TRASERA
Mod. 79-89 FAT1900

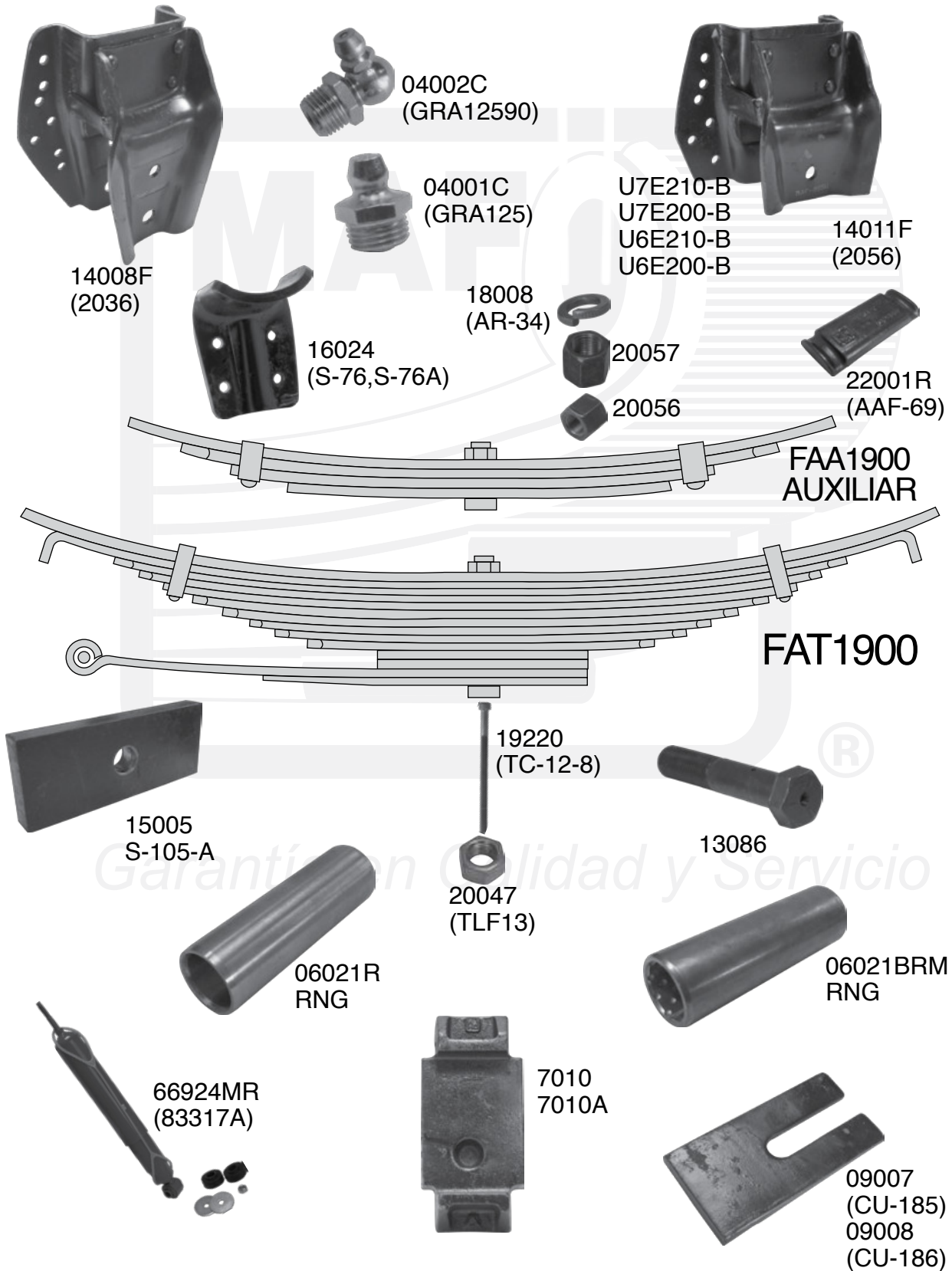

FAMSA S-1900 SUSPENSIÓN TRASERA Mod. 79-89 FAT1900

CÓDIGO	No. MAF	DESCRIPCIÓN	CANTIDAD
14008F	2036	PERCHA DER-IZQ TRAS. DEL # 3	2
14011F	2056	PERCHA DER-IZQ. TRAS. TRAS. #4	2
U6E200-B	U-6E200-B	TORNILLO "U" 3/4" x 3 1/16" x 20.00"	4
U7E200-B	U-7E200-B	TORNILLO "U" 7/8" x 3 1/16" x 20.00"	4
U6E210-B	U-6E210-B	TORNILLO "U" 3/4" x 3 1/16" x 21.00"	4
U7E210-B	U-7E210-B	TORNILLO "U" 7/8" x 3 1/16" x 21.00"	4
13086	13086	PERNO CAB.HEX. 1.00" x 5.00" C/GRASERA	4
04001C	GRA125	GRASERA RECTA DE 1/8" NPT	2
04002C	GRA12590	GRASERA DE 1/8" NPT 90°	2
16024	S-76,S-76-A	SOPORTE	4
22001R	AAF-69	ASIENTO ABRAZADERA	2
19220	TC-12-8	TORNILLO DE CENTRO 1/2" x 8"	2
19206	TC-38-4	TORNILLO DE CENTRO 3/8" x 4"	2
20047	TLF13	TUERCA UNF GRADO DE 1/2"	4
15005	S-105-A	SEPARADOR 3.00" x 7 1/2" x 7/8"	4
06021BM	RNG	BUJE BI-METÁLICO 1 1/2" x 1 1/4" x 3.00"	2
06021R	RNG	BUJE BRONCE 1 1/2" x 1 1/4" x 3.00"	2
66924MR	66924	AMORT. MONROE = 83317 MERITOR	2
09007	CU-185	CUÑA	2
09008	CU-186	CUÑA	2
7010	7010	CUÑA DERECHA	1
7010A	7010A	CUÑA IZQUIERDA	1
20056	9054	TUERCA FINA ALTA DE 3/4" °8	8
20057	9055	TUERCA FINA ALTA DE 7/8" °8	8
18009	AR-78	RONDANA DE PRESIÓN 3/4" P/REFACCIÓN	8
FAA1900	FAA-1900	MUELLE AUXILIAR 4 HOJAS	8
		3." x .360" x 19 3/4" x 19 3/4"	
FAT1900	FAT-1900	MUELLE COMPLETA 14 HOJAS	2
		HOJA 01 3. x .499" x 30 1/4" x 30 1/4"	2

VER CATÁLOGO DE MUELLES MAF 2011

FAMSA

FAMSA S-1900 SUSPENSIÓN TRASERA Mod. 79-89 FAT1900

PERCHA FAMSA DER.
IZQ. TRAS. DEL. #3



CÓDIGO: 14008F
No. MAF: 2036

MAF

PERCHA FAMSA
DER. IZQ. TRAS. TRAS.
#4



CÓDIGO: 14011F
No. MAF: 2056

MAF

TORNILLO "U"
3/4" x 3 1/16" x 20.00



CÓDIGO: U6E200-B
No. MAF: U-6E150-B

MAF

TORNILLO "U"
7/8" x 3 1/16" x 20.00



CÓDIGO: U7E200-B
No. MAF: U-7E200-B

MAF

TORNILLO "U"
3/4" x 3 1/16" x 21.00



CÓDIGO: U6E210-B
No. MAF: U-6E210-B

MAF

TORNILLO "U"
7/8" x 3 1/16" x 21.00



CÓDIGO: U7E210-B
No. MAF: U-7E210-B

MAF

PERNO CAB. HEX.
1.00" x 5.00"
C/GRASERA



CÓDIGO: 13086
No. MAF: 13086

MAF

TORNILLO DE
CENTRO 1/2" x 8.00"



CÓDIGO: 19220
No. MAF: TC-12-8

MAF

GRASERA DE 1/8
NPT 90°



CÓDIGO: 04002C
No. MAF: GRA12590

MAF

GRASERA RECTA
NPT 1/8"



CÓDIGO: 04001C
No. MAF: GRA125

MAF

SOPORTE



CÓDIGO: 16024
No. MAF: S-76, S-76A

MAF

ASIENTO
ABRAZADERA



CÓDIGO: 22001R
No. MAF: AAF-69

MAF

FAMSA

FAMSA S-1900 SUSPENSIÓN TRASERA Mod. 79-89 FAT1900

<p>TUERCA FINA ALTA 7/8" Ø8</p>  <p>CÓDIGO: 20057 No. MAF: 9055</p> <p>MAF</p>	<p>TUERCA UNF Ø2 DE 1/2"</p>  <p>CÓDIGO: 20047 No. MAF: TLF13</p> <p>MAF</p>	<p>BUJE BRONCE 1 1/2" x 1 1/4" x 3.00"</p>  <p>CODIGO: 06021R No. MAF: RNG</p> <p>MAF</p>	<p>BUJE BRONCE 1 1/2" x 1 1/4" x 3.00"</p>  <p>CODIGO: 06021BM No. MAF: RNG</p> <p>MAF</p>
<p>CUÑA</p>  <p>CÓDIGO: 09007 No. MAF: CU-185</p> <p>MAF</p>	<p>CUÑA</p>  <p>CÓDIGO: 09008 No. MAF: CU-186</p> <p>MAF</p>	<p>CUÑA DERECHA</p>  <p>CÓDIGO: 7010 No. MAF: 7010</p> <p>MAF</p>	<p>CUÑA IZQUIERDA</p>  <p>CÓDIGO: 7010A No. MAF: 7010A</p> <p>MAF</p>
<p>TUERCA FINA ALTA 3/4" Ø8</p>  <p>CÓDIGO: 20056 No. MAF: 9054</p> <p>MAF</p>	<p>RONDANA DE PRESIÓN 3/4"</p>  <p>CÓDIGO: 18008 No. MAF: AR-34</p> <p>MAF</p>	<p>SEPARADOR 3.00" x 7 1/2" x 7/8"</p>  <p>CÓDIGO: 15005 No. MAF: S-105-A</p> <p>MAF</p>	<p>AMORTIGUADOR MONROE = 83317 MERITOR</p>  <p>CÓDIGO: 66924MR No. MAF: 66924</p> <p>MAF</p>

FAMSA

FAMSA S-1900
SUSPENSIÓN TRASERA
Mod. 79-89 FAT1900RONDANA DE
PRESIÓN 7/8"CÓDIGO: 18009
No. MAF: AR-78

MAF



Muelles parabólicas

Productos MAF para otras aplicaciones



Para mayor información consulte al ejecutivo de ventas

FREIGHTLINER
TRACTOCAMIÓN FREIGHTLINER
FLC / FLD 120 85- 2005 MUELLE
PARABÓLICA DEL. 46220F

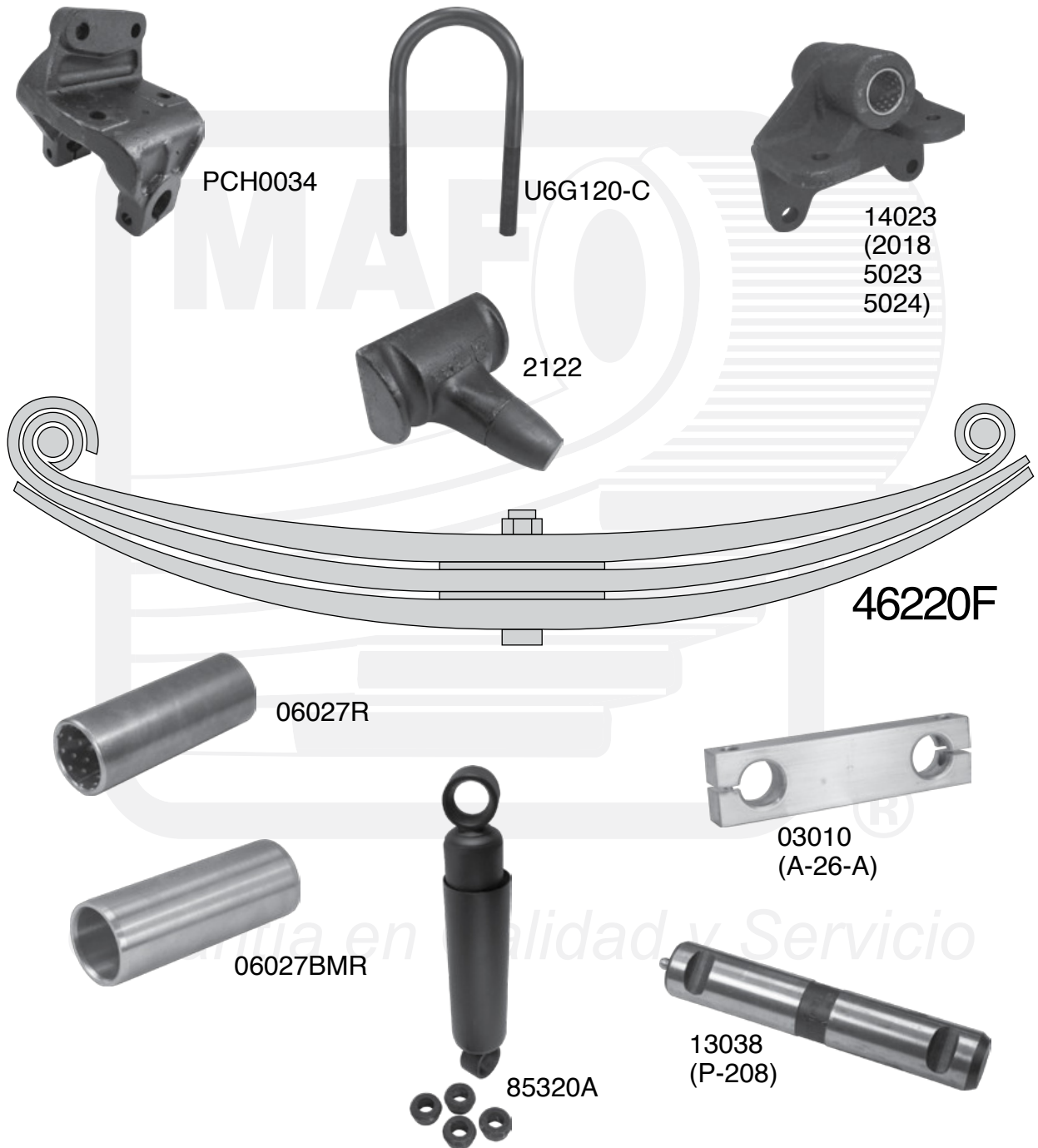

FREIGHTLINER

TRACTOCAMIÓN FREIGHTLINER
FLC / FLD 120 85- 2005 MUELLE
PARABÓLICA DEL. 46220F

CÓDIGO	No. MAF	DESCRIPCIÓN	CANTIDAD
13038	P-208	P-208 PERNO FREIGHTLINER (# M.POWER. MP-209)	6
03010	A-26-A	ALBARDÓN FREIGHTLINER LARGO (.667 kg.)	4
85320A	85320	AMORTIGUADOR MERITOR = 65103 MONROE	2
5023	2018	PERCHA DEL TRASERA PHM	
5024	5024	PERCHA PARA FREIGHT. TIPO VIEJO FUNDICIÓN	2
14023	2018	PERCHA DELANTERA TRASERA	2
2122	2122	SOBRE MUELLE P/FREIGHTLINER C/TOPE DE HULE	2
PCH0034	PCH0034	PERCHA DEL. DEL. FREIGHTLINER (5602) PHM 4013	4
06027R	RNK 254-2	BUJE BRONCE 1 1/2" x 1 1/4" x 4.00" RNK 254-2	
06027BMR	RNK BIMETALICO	BUJE BI-METÁLICO 1 1/2" x 1 1/4" x 4.00"	4
U6G120-C	U-6G120-C	TORNILLO "U" 3/4" x 4 1/16" x 12.00"	
46220F	46-220	MUELLE COMPLETA PARABÓLICA 3 HOJAS	2

4" x .662" x 26" x 29" CON BUJES RNK

VER CATÁLOGO DE MUELLES MAF 2011 PARA MÁS

DETALLE DE ESPESORES



Garantía en Calidad y Servicio

FREIGHTLINER TRACTOCAMIÓN FREIGHTLINER FLC / FLD 120 85- 2005 MUELLE PARABÓLICA DEL. 46220F

PERNO FREIGHTLINER
(#M. POWER. MP-209)
MIG



CÓDIGO: 13038
No. MAF: P-208

MAF

ALBARDÓN
FREIGHTLINER LARGO
(.677kg)



CÓDIGO: 03010
No. MAF: A-26-A

MAF

AMORT. MERITOR =
65103 MONROE



CÓDIGO: 85320A
No. MAF: 85320

MAF

PERCHA DEL. TRAS.
FREIGHTLINER P/COL
(IMO-5603)



CÓDIGO: 5023
No. MAF: 2018

MAF

SOBRE MUELLE
C/TOPE DE HULE



CÓDIGO: 2122
No. MAF: 2122

MAF

PERCHA DEL. DEL.



CÓDIGO: PCH0034
No. MAF: PCH0034

MAF

BUJE BRONCE
1 1/2" x 1 1/4" x 4.00"



CODIGO: 06027R
No. MAF: RNK 254-2

MAF

BUJE-BIMETALICO
1 1/2" x 1 1/4" x 4.00"



CODIGO: 06027BMR
No. MAF: RNK
BIMETALICO

MAF

TORNILLO "U"
3/4" x 4 1/16" x 12.00"



CÓDIGO: U6G120-C
No. MAF: U-6G120-C

MAF

PERCHA PARA
FREIGHTLINER TIPO
VIEJO FUND.



CÓDIGO: 5024
No. MAF: 5024

MAF

PERCHA DEL. TRAS.



CÓDIGO: 14023
No. MAF: 2018

MAF

FREIGHTLINER

FREIGHTLINER FL70/FL8

MODELO 94/2000

MUELLE DEL. 461240F

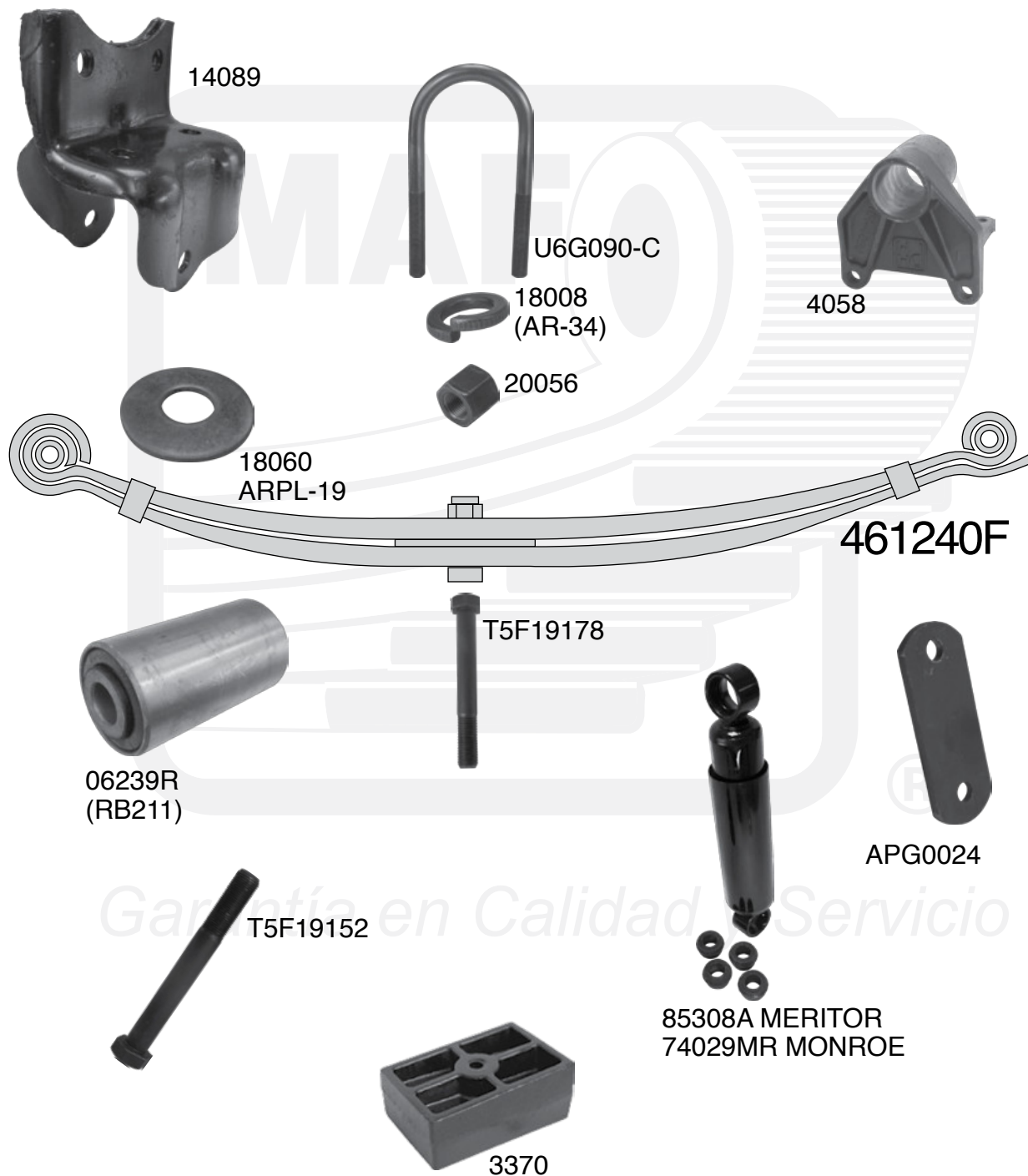

FREIGHTLINER

FREIGHTLINER FL70/FL8

MODELO 94/2000

MUELLE DEL. 461240F

CÓDIGO	No. MAF	DESCRIPCIÓN	CANTIDAD
14089	5001	PERCHA DEL. DEL. FREIGHTLINER FL-70,80 00-03	2
4058	4058	PERCHA COLUMPIO PARA BUJE RB FLT A16-14725	2
3370	3370	CUÑA MUELLE 4" DELANTERA 5 STERLING,FTL	2
06239R	RB-211	BUJE FIERRO Y HULE, RB-211=RB-233=RB-1017 IARSA	6
06239RC	RB-211	BUJE BR-211=RB-1017=RB-233 CLEVITE	
2122	2122	SOBRE MUELLE P/FREIGHTLINER C/TOPE DE HULE	2
T5F19152	T5F19152	TORNILLO CAB. HEXAGONAL 5 NF DE 3/4" x 6.00"	6
T5F19152PC	T5F19152PC	TORNILLO CAB. HEXAGONAL 5 NF DE 3/4" x 6.00"	6
T5F19178	T5F19178	TORNILLO CAB. HEXAGONAL 5 NF DE 3/4" x 7.00"	6
T5F19178PC	T5F19178PC	TORNILLO CAB. HEXAGONAL 5 NF DE 3/4" x 7.00"	2
APG0024	APG0024	ALBARDÓN PLACA C120064ST FLT MOD. 99-05	2
U6G090-C	U-6G090-C	TORNILLO "U" 3/4" x 4 1/16" x 9.00"	4
20056	9054	TUERCA FINA ALTA DE 3/4" - 9054 °8	8
18008	AR-34	RONDANA DE PRESIÓN 3/4"	8
18060	ARPL-19	RONDANA PLANA DE 3/4"	6
85308A	85308	AMORTIGUADOR MERITOR 74029 MONROE	2
74029MR	74029	AMORTIGUADOR MONROE = 85308 MERITOR	2
461240F	461240F	MUELLE COMPLETA PARAB. DE 2 HOJAS	2
		HOJA 01 Y 02 4." x .788" x 28" x 33" BUJE RB-211	
461240R	461240R	MUELLE CON UNA HOJA DE REFUERZO	2
		HOJA 03 4" x .815" x 29" x 34"	

VER CATÁLOGO DE MUELLES 2011

FREIGHTLINER

FREIGHTLINER FL70/FL8 MODELO 94/2000 MUELLE DEL. 461240F

PERCHA DEL. DEL.



CÓDIGO: 14089
No. MAF: 5001

MAF

PERCHA DEL. TRAS.
C/BUJE RB



CÓDIGO: 4058
No. MAF: 4058

MAF

CUÑA MUELLE #4
DELANTERA °5



CÓDIGO: 3370
No. MAF: 3370

MAF

BUJE FIERRO Y HULE
RB-211 = RB-233 =
RB-1017 IARSA

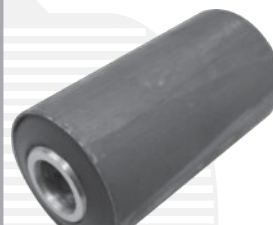

CÓDIGO: 06239R
No. MAF: RB211

MAF

SOBRE MUELLE



CÓDIGO: 2122
No. MAF: 2122

MAF

TORNILLO CAB. HEX
°5 NF DE 3/4" x 6.00"



CÓDIGO: T5F19152
No. MAF: T5F19152

MAF

TORNILLO CAB. HEX
°5 NF DE 3/4" x 7.00"



CÓDIGO: T5F19178
No. MAF: T5F19178

MAF

ALBARDÓN PLACA



CÓDIGO: APG0024
No. MAF: APG0024

MAF

TORNILLO "U"
3/4" x 4 1/16" x 9.00



CÓDIGO: U6G090-C
No. MAF: U-6G090-C

MAF

TUERCA FINA ALTA
3/4" °8



CÓDIGO: 20056
No. MAF: 9054

MAF

RONDANA DE
PRESIÓN 3/4"



CÓDIGO: 18008
No. MAF: AR-34

MAF

RONDANA PLANA
DE 3/4"



CÓDIGO: 18060
No. MAF: ARPL-19

MAF

FREIGHTLINER
 FREIGHTLINER FL70/FL8
 MODELO 94/2000
 MUELLE DEL. 461240F

AMORT. MERITOR =
74029 MONROE



CÓDIGO: 85308A
 No. MAF: 85308

MAF

TORNILLO CAB. HEX
°5 NF DE 3/4" x 6.00"



CÓDIGO: T5F19152PC
 No. MAF: T5F19152PC

MAF

TORNILLO CAB. HEX
°5 NF DE 3/4" x 7.00"



CÓDIGO: T5F19178PC
 No. MAF: T5F19178PC

MAF



Muelles tipo "Z"

Productos MAF para otras aplicaciones



Garantía en Calidad y Servicio

Para mayor información consulte al ejecutivo de ventas

FREIGHTLINER

BUSINESS CLASS M2 SUSPENSIÓN TRASERA FLT338

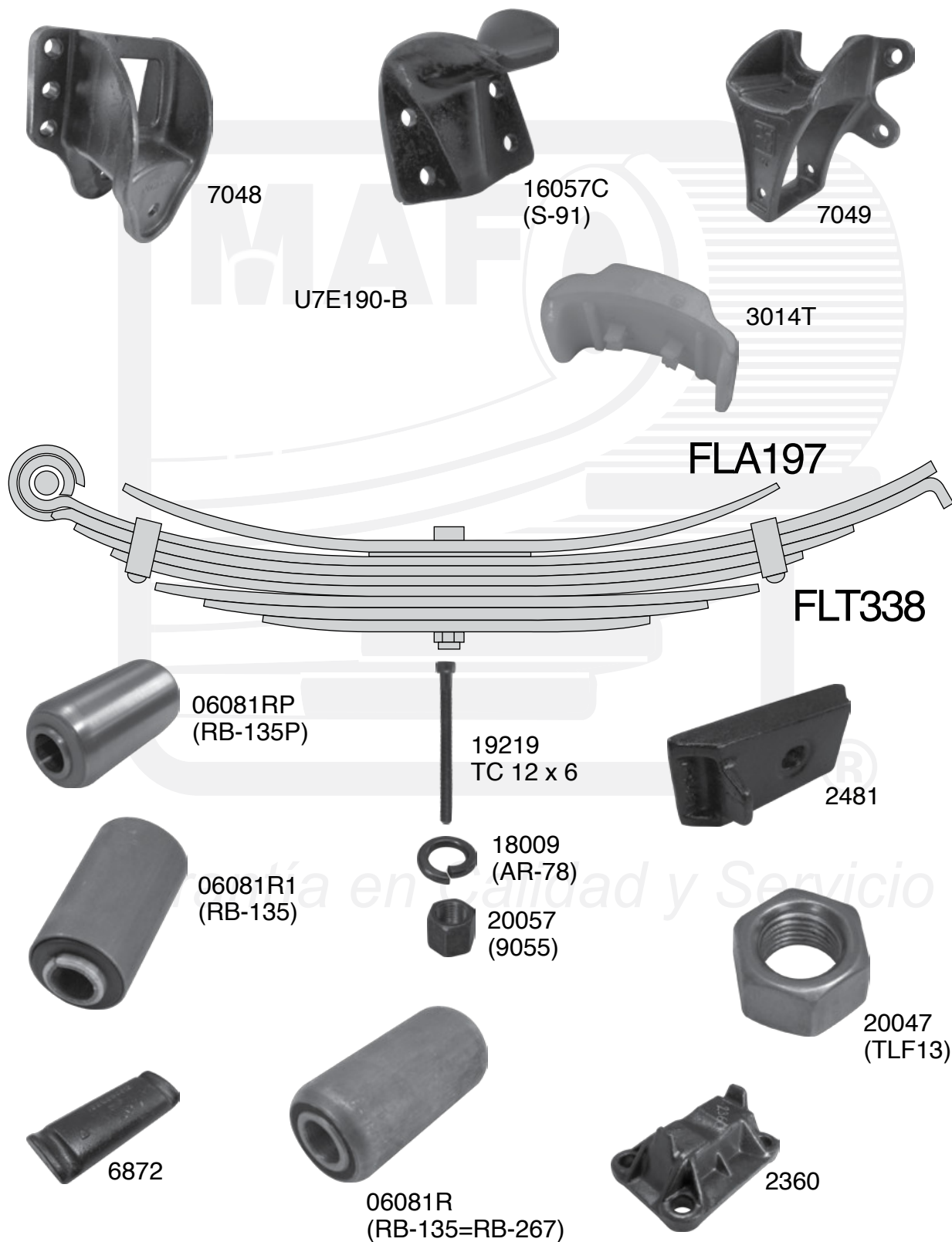

FREIGHTLINER

BUSINESS CLASS M2

SUSPENSIÓN TRASERA FLT338

CÓDIGO	No. MAF	DESCRIPCIÓN	CANTIDAD
7048	7048	PERCHA TRASERA DELANTERA	2
7049	7049	PERCHA TRASERA TRASERA	2
16057C	S-91	SOPORTE SOBRE CARGA	2
2360	2360	TAPA INFERIOR	2
6872	6872	ASIENTO ABRAZADERA	2
2481	2481	ASIENTO MUELLE	2
3014T	3014T	ZAPATA DE DESGASTE	2
U7E190-B	U-7E190-B	TORNILLO "U" 7/8" x 3 1/16" x 19.00"	4
06081RP.	RB-135P	BUJE FIERRO Y POLIURETANO	2
06081RI	RB-135	BUJE FIERRO Y HULE ENGARGOLADO	2
06081R	RB-135=RB-267	BUJE FIERRO Y HULE NORMAL	2
18009	AR-78	RONDANA DE PRESIÓN 7/8"	8
20057	9055	TUERCA FINA ALTA DE 7/8" °8	8
19219	TC-12-6	TORNILLO CENTRO 1/2" x 6.00"	2
20047	TLF13	TUERCA UNF. °2 1/2"	2
FLA197	FLA-197	HOJA AUXILIAR	2
		3.00" x .788" x 19 1/4" x 19 1/4"	
FLT338	FLT-338	MUELLE COMPLETA 7 HOJAS	2
		HOJA 01 4" x .702" x 26 1/8" x 30 1/2"	

VER CATÁLOGO DE MUELLES MAF 2011

Garantía en Calidad y Servicio

FREIGHTLINER BUSINESS CLASS M2 SUSPENSIÓN TRASERA FLT338

PERCHA TRAS. DEL.
FUNDICIÓN



CÓDIGO: 7048
No. MAF: 7048

MAF

PERCHA TRAS.
FUNDICIÓN



CÓDIGO: 7049
No. MAF: 7049

MAF

SOPORTE SOBRE
CARGA.



CÓDIGO: 16057C
No. MAF: S-91

MAF

TAPA INFERIOR



CÓDIGO: 2360
No. MAF: 2360

MAF

ASIENTO DE
ABRAZADERA



CÓDIGO: 6872
No. MAF: 6872

MAF

ASIENTO
MUELLE



CÓDIGO: 2481
No. MAF: 2481

MAF

ZAPATA DE
DESGASTE



CÓDIGO: 3014T
No. MAF: 3014T

MAF

TORNILLO "U"
7/8" x 3 1/16" x 19.00"

CÓDIGO: U7E190-B
No. MAF: U-7E190-B

MAF

BUJE DE FIERRO Y
POLIURETANO



CÓDIGO: 06081RP
No. MAF: RB-135P

MAF

BUJE DE FIERRO Y
HULE ENGARGOLADO



CÓDIGO: 06081R1
No. MAF: RB-135

MAF

BUJE DE FIERRO Y
HULE NORMAL



CÓDIGO: 06081R
No. MAF: RB-135/RB-267

MAF

RONDANA DE
PRESIÓN 7/8"



CÓDIGO: 18009
No. MAF: AR-78

MAF

FREIGHTLINER

BUSINESS CLASS M2

SUSPENSIÓN TRASERA FLT338

TUERCA FINA ALTA
7/8" Ø8



CÓDIGO: 20057
No. MAF: 9055

MAF

TORNILLO CENTRO
1/2" x 6.00"



CÓDIGO: 19219
No. MAF: TC-12-6

MAF

TUERCA UNF
1/2" Ø2



CÓDIGO: 20047
No. MAF: TLF-13

MAF



Catálogo de muelles



Para mayor información consulte al ejecutivo de ventas

FREIGHTLINER

FREIGHTLINER M2 DELANTERA 461464RF (A16-16789-000)

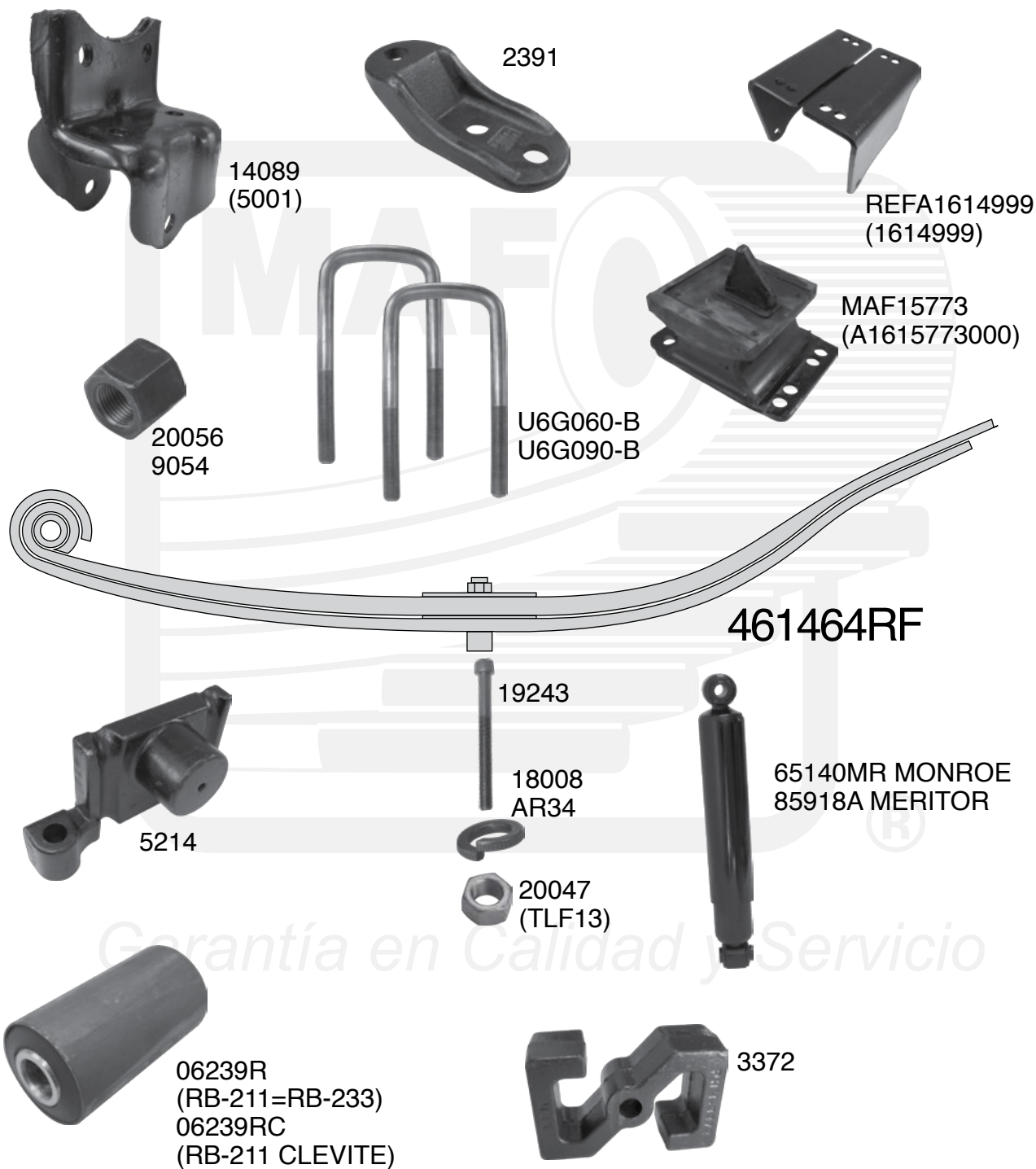

Garantía en Calidad y Servicio

MUELLE ORIGINAL

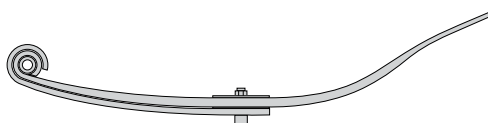

FREIGHTLINER

FREIGHTLINER M2 DELANTERA 461464RF (A16-16789-000)

CÓDIGO	No. MAF	DESCRIPCIÓN	CANTIDAD
2391	2391	SOPORTE AMORTIGUADOR	2
REFA1614999	614999	SOPORTE DEL. SUSPENSIÓN FREIGHTLINER	2
14089	5001	PERCHA DELANTERA-DELANTERA.	2
5214	5214	SOBRE MUELLE C/SOPORTE DE AMORTIGUADOR	2
06239R	RB-211=RB-233	BUJE FIERRO Y HULE	2
06239RC	RB-211	BUJE FIERRO Y HULE CLEVITE	2
3372	3372	TACÓN SEPARADOR Z DE 2 1/4" x 4" x 6 3/8"	2
MAF15773	A1615773000	SOPORTE DE CARGA	2
65140MR	65140	AMORTIGUADOR MONROE	2
85918A	85918A	AMORTIGUADOR MERITOR	2
U6G060-B	U-6G060-B	TORNILLO "U" 3/4" x 4" 1/16" x 6.00"	2
U6G090-B	U-6G090-B	TORNILLO "U" 3/4" x 4" 1/16" x 9.00"	2
19243	19243	TORNILLO DE CENTRO 1/2" x 3 1/4" x 3/4" x 7/16"	2
20047	TLF13	TUERCA FINA 1/2" °2	8
20056	9054	TUERCA FINA ALTA 3/4" °8	8
18008	AR34	RONDANA DE PRESIÓN 3/4"	2
461464RF	46-1464RF	MUELLE PARABÓLICA 2 HOJAS	2
461464BF-01	46-1464BF-01	HOJA 1ra 4." x .999" x 26" x 33"	
461464F-02	46-1464F-02	HOJA 2da 4." x .401" x 26" x 3 1/2"	
461464F-02R	46-1464F-02R	HOJA 2da REFUERZO 4." x .815" x 26" x 29"	

Garantía en Calidad y Servicio

VER CATÁLOGO DE MUELLES MAF 2011

FREIGHTLINER

FREIGHTLINER M2 DELANTERA 461464RF (A16-16789-000)

<p>PERCHA DEL. DEL.</p>  <p>CÓDIGO: 14089 No. MAF: 5001</p> <p>MAF</p>	<p>TORNILLO "U" 3/4" x 4.00" x 9.00"</p>  <p>CÓDIGO: U6G090-B No. MAF: U-6G090-B</p> <p>MAF</p>	<p>TORNILLO "U" 3/4" x 4.00" x 6.00"</p>  <p>CÓDIGO: U6G060-B No. MAF: U-6G060-B</p> <p>MAF</p>	<p>SOPORTE DELANTERO</p>  <p>CÓDIGO: REFA1614999 No. MAF: 1614999</p> <p>MAF</p>
<p>SOPORTE DE CARGA</p>  <p>CÓDIGO: MAF15773 No. MAF: A1615773000</p> <p>MAF</p>	<p>TACÓN SEPARADOR</p>  <p>CÓDIGO: 3372 No. MAF: 3372</p> <p>MAF</p>	<p>BUJE FIERRO Y HULE</p>  <p>CÓDIGO: 06239R No. MAF: RB-211</p> <p>MAF</p>	<p>SOBRE MUELLE C/SOPORTE</p>  <p>CÓDIGO: 5214 No. MAF: 5214</p> <p>MAF</p>
<p>SOPORTE AMORTIGUADOR</p>  <p>CÓDIGO: 2391 No. MAF: 2391</p> <p>MAF</p>	<p>AMORTIGUADOR MONROE</p>  <p>CÓDIGO: 65140MR No. MAF: 65140</p> <p>MAF</p>	<p>TORNILLO DE CENTRO 1/2" 3 1/4" x 3/4" x 7/16"</p>  <p>CÓDIGO: 19243 No. MAF: 19243</p> <p>MAF</p>	<p>TUERCA FINA ALTA 1/2" 2</p>  <p>CÓDIGO: 20047 No. MAF: TLF13</p> <p>MAF</p>

FREIGHTLINER

FREIGHTLINER M2 DELANTERA

461464RF (A16-16789-000)

BUJE PARA MUELLE
RB-211 EXT 2 1/4 INT 3/4
LG 4 1/4



CÓDIGO: 06239RC
No. MAF: RB-211

TUERCA FINA ALTA
3/4" 98



CÓDIGO: 20056
No. MAF: 9054

RONDANA DE PRESIÓN 3/4"



CÓDIGO: 18008
No. MAF: AR-34

AMORTIGUADOR MERITOR



CÓDIGO: 85918A
No. MAF: 85918A

Especificaciones de seguridad y mantenimiento para los Tornillos "U" fabricados por MAF

Los Tornillos "U" fabricados por MAF con ACERO 1045 grado 5 sufre mínimo estiramiento, si se excede del toque indicado.

Los Tornillos "U" con tuercas del mismo grado deben de mantenerse apretados conforme a la siguiente tabla:

0 1/2"	92Lbs/pie	0 5/8"	154Lbs/pie	0 7/8"	382Lbs/pie	0 1 1/8"	872Lbs/pie
0 9/16"	114Lbs/pie	0 3/4"	257Lbs/pie	0 1"	587Lbs/pie	0 1 1/4"	1,211Lbs/pie

*Fuente de información: <http://www.thelenchannel.com/1torque.php>

"Al hacer caso omiso de reapretar nuevamente los Tornillos "U", la suspensión y la muelle podrían sufrir un serio daño."



FREIGHTLINER

FAS II AIRLINER EJE SENCILLO Y DOBLE MODELO 90 -00 MUELLE 461217F

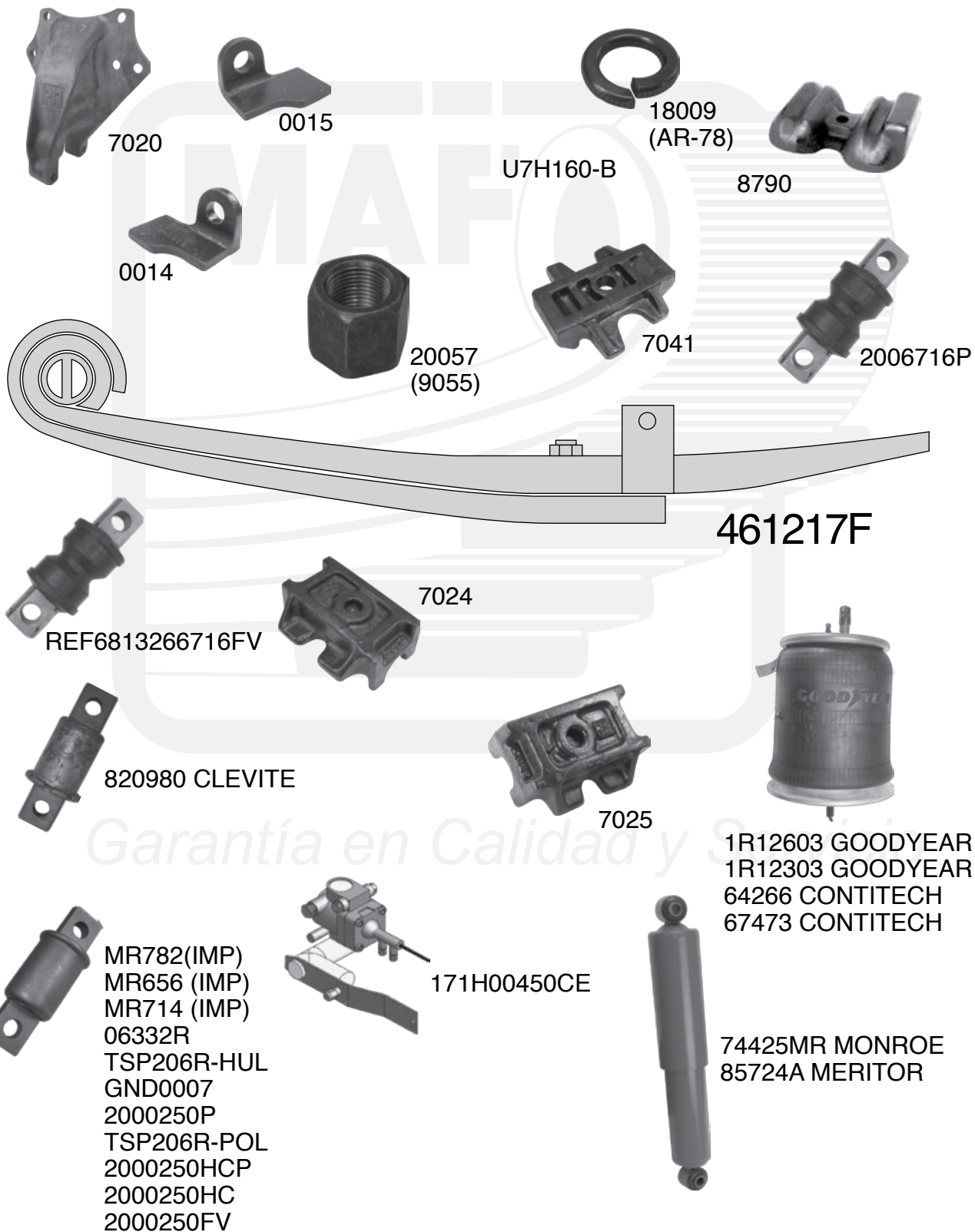

FREIGHTLINER

FAS II AIRLINER

EJE SENCILLO Y DOBLE

MODELO 90 -00 MUELLE 461217F

CÓDIGO	No. MAF	DESCRIPCIÓN	CANTIDAD
7020	7020	PERCHA FREIGHTLINER FAS II FUNDICIÓN	2
7041	7041	CUÑA FREIGHTLINER °3	2
820980	820980	P/B TORSIÓN TSP206R-HUL #ORIG.681-325-01-05	2
MR782	MR782	GRANADA C/GUARDAPOLVO (OEM=1616412)	2
0014	0014	ZAPATA DE DESGASTE DERECHA	2
0015	0015	ZAPATA DE DESGASTE IZQUIERDA	2
8790	8790	ASIENTO ABRAZADOR SUSPENSIÓN DE AIRE	2
7024	7024	CUÑA SUSPENSIÓN IZQUIERDA	2
7025	7025	CUÑA SUSPENSIÓN DERECHA	2
REF6813266716FV	6813266716	GRANADA DE HULE 2 1/16"	2
1R12603	1R12603	W013589780 AIR SPRING GOODYEAR	2
1R12303	1R12303	AIR SPRING GOODYEAR	2
64266	64266	BOLSA DE AIRE CONTITECH	2
67473	67473	BOLSA DE AIRE CONTITECH	2
06332R	RB.205	BUJE FIERRO Y HULE RB-205	2
TSP206R-HUL	RB-205	BUJE PARA BARRA DE TORSIÓN HULE	2
TSP206R-POL	TSP206R	BUJE PARA BARRA DE TORSIÓN POLIURETANO	2
171H00450CE	171H00450CE	VÁLVULA NIVELADORA HADLEY UNIVERSAL	1
U7H160-B	U-7H160-B	TORNILLO "U" 7/8" x 5 1/16" x 16.00"	4
20057	9055	TUERCA ALTA 7/8" °8	8
18009	AR-78	RONDANA DE PRESIÓN 7/8"	8
2000250HC	TSP-206R-HUL	P/B TORSIÓN #681-325-01-50 ALTO CONF. HULE	2
2000250HCP	200-0250HCP	P/B TORSIÓN TSP206R - POL. ALTO CONF.	2
2000250P	200-0250P	FREIGHTLINER P/B TORSIÓN	2
GND0007	GND-0007	GRANADA FREIGHTLINER	2
MR656	MR656	GRANADA DE HULE RB-205 2 1/2" x 3" x 7 1/2"	2
MR714	MR714	BUJE MUELLE	2
74425MR	74424	AMORTIGUADOR MONROE = 85724 MERITOR	2

FREIGHTLINER

FAS II AIRLINER
EJE SENCILLO Y DOBLE
MODELO 90 -00 MUELLE 461217F

CÓDIGO	No. MAF	DESCRIPCIÓN	CANTIDAD
85724A	85724	AMORTIGUADOR MERITOR = 65490 Y/O 74425 MONROE	2
2000250FV	GND-0007	GRANADA FREIGHTLINER	2
2006716P	200671	NÚCLEO PARA TENSOR POLIURETANO	2
461217F	461217F	MUELLE DE 2 HOJAS PARABÓLICA	2
		3" x 1.625" x 25 3/4" x 20" CON GRANADA RB-205	
461217		SOPORTE AMORTIGUADOR P/MUELLE 461217	2

VER CATÁLOGO DE MUELLES MAF 2011

Recomendaciones para la instalación de Tornillos "U"

1. Se debe de tener mucho cuidado al apretar los Tornillos "U" que sujetan la muelle al eje procurando que asienten correctamente en el eje y asientos de los Tornillos "U" con su respectivo torque de apriete.
2. De quedar flojos, originarán el desplazamiento de la muelle, rompimiento de la cabeza del tornillo de centro y fractura de las hojas al centro, donde está la perforación central. (Esta área debe de quedar sin movimiento).
3. Si queda demasiado apretado, se atasca la tuerca, desprendimiento de los hilos de la cuerda, posible fractura del Tornillo "U", esto provoca que se desprenda de su lugar, dejando suelta la muelle repercutiendo en una falla.
4. Se recomienda reapretar los Tornillos "U" después de haberse instalados, los primeros 500 kilómetros de recorrido y a los siguientes 1000 Km. Esto garantiza el torque hasta una próxima reparación de la muelle.



No es recomendable volver a usar los Tornillos "U", al reparar las muelles, estos ya cumplieron su ciclo de vida.

FREIGHTLINER

FAS II AIRLINER

EJE SENCILLO Y DOBLE

MODELO 90 -00 MUELLE 461217F

PERCHA FAS II
FUNDICIÓN



CÓDIGO: 7020
No. MAF: 7020

MAF

CUÑA '03



CÓDIGO: 7041
No. MAF: 7041

MAF

GRANADA DE HULE
RB-205
2 1/2" x 3" x 7 1/2"



CÓDIGO: 820980
No. MAF: 820980

MAF

GRANADA CUADRADA
C/GUARDA POLVO
(OEM=1616412)



CÓDIGO: MR782
No. MAF: MR782

MAF

ZAPATA DE
DESGASTE DERECHA



CÓDIGO: 0014
No. MAF: 0014

MAF

ZAPATA DE
DESGASTE IZQUIERDA



CÓDIGO: 0015
No. MAF: 0015

MAF

ASIENTO
ABRAZADERA SUSP.
AIRE



CÓDIGO: 8790
No. MAF: 8790

MAF

CUÑA SUSP.
IZQUIERDA



CÓDIGO: 7024
No. MAF: 7024

MAF

CUÑA SUSP.
DERECHA



CÓDIGO: 7025
No. MAF: 7025

MAF

GRANADA DE HULE
RB-205
2 1/2" x 3" x 7 1/2"



CÓDIGO: 6813266716V
No. MAF: 6813266716

MAF

AIR SPRING
GOODYEAR



CÓDIGO: 1R12603
No. MAF: 1R12603

MAF

AIR SPRING
GOODYEAR



CÓDIGO: 1R12303
No. MAF: 1R12303

MAF

FREIGHTLINER

FAS II AIRLINER EJE SENCILLO Y DOBLE MODELO 90 -00 MUELLE 461217F

BOLSA DE AIRE
CONTITECH



CÓDIGO: 64266
No. MAF: 64266

MAF

BOLSA DE AIRE
CONTITECH



CÓDIGO: 67473
No. MAF: 67473

MAF

GRANADA DE HULE



CÓDIGO: 06332R
No. MAF: RB-205

MAF



MAF

GRANADA DE HULE
RB-205
2 1/2" x 3" x 7 1/2"



CÓDIGO: TSP206R-POL
No. MAF: RB-205

MAF

TORNILLO "U"
7/8" x 5 1/16" x 16.00"



CÓDIGO: U7H160-B
No. MAF: U-7H160-B

MAF

TUERCA FINA ALTA
7/8" 08



CÓDIGO: 20057
No. MAF: 9055

MAF

TUERCA FINA ALTA
7/8" 08



CÓDIGO: 20057PC
No. MAF: 20057PC

MAF

RONDANA DE
PRESIÓN 7/8"



CÓDIGO: 18009
No. MAF: AR-78

MAF

VÁLVULA NIVELADORA
HADLEY UNIVERSAL

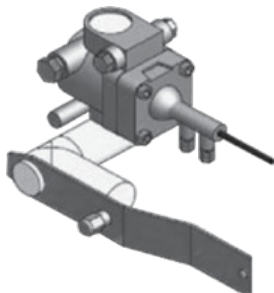

CÓDIGO: 171H00450CE
No. MAF: 171H00450CE

MAF

GRANADA DE HULE
RB-205
2 1/2" x 3" x 7 1/2"



CÓDIGO: 2000250HC
No. MAF: TSP-206R-HUL

MAF







GRANADA DE HULE
RB-205 POLIURETANO
2 1/2" x 3" x 7 1/2"



CÓDIGO: 2000250HCP
No. MAF: 200-0250HCP

MAF

FREIGHTLINER
 FAS II AIRLINER
 EJE SENCILLO Y DOBLE
 MODELO 90 -00 MUELLE 461217F

<p>GRANADA DE HULE RB-205 2 1/2" x 3" x 7 1/2"</p>  <p>CÓDIGO: GDN0007 No. MAF: GDN-0007</p>	<p>GRANADA DE HULE RB-205 2 1/2" x 3" x 7 1/2"</p>  <p>CÓDIGO: MR656 No. MAF: MR656</p>	<p>AMORTIGUADOR MONROE = 74425 MERITOR</p>  <p>CÓDIGO: 74425MR No. MAF: 74424</p>	<p>AMORTIGUADOR MONROE = 85724 MERITOR</p>  <p>CÓDIGO: 85724A No. MAF: 85724</p>
<p>GRANADA DE POLIURETANO</p>  <p>CÓDIGO: 2000250P No. MAF: 2000-250P</p>	<p>GRANADA DE HULE</p>  <p>CÓDIGO: MR714 No. MAF: MR714</p>	<p>NÚCLEO TENSOR POLIURETANO</p>  <p>CÓDIGO: 2006716P No. MAF: 2006716P</p>	<p>GRANADA FREIGHTLINER</p>  <p>CÓDIGO: 2000250FV No. MAF: GND-0007</p>

Garantía en Calidad y Servicio

FREIGHTLINER

TRACTOCAMIÓN FREIGHTLINER FLD / FLD 120 84-00 MUELLE PARABÓLICA DEL. 461280

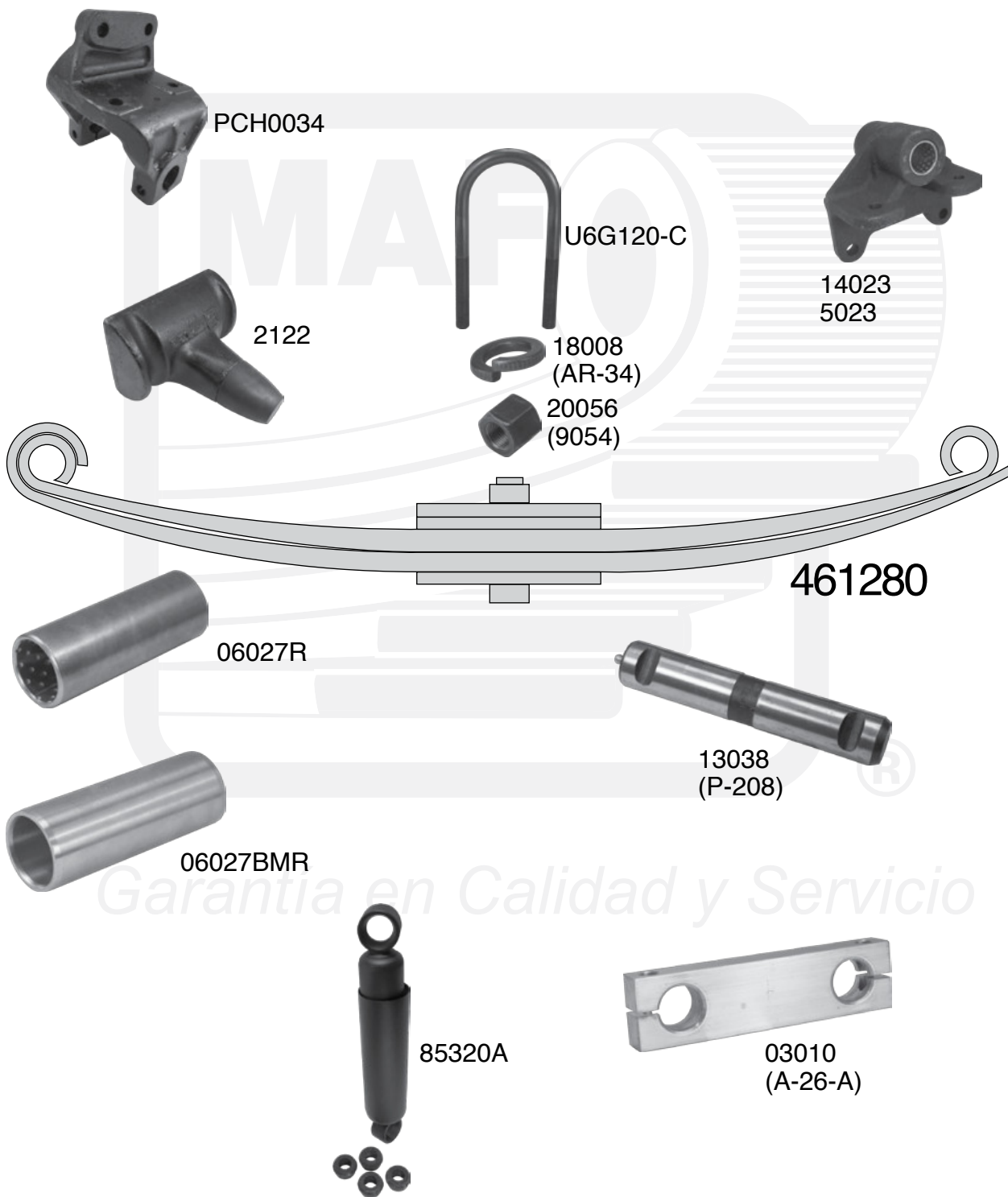

Garantía en Calidad y Servicio

FREIGHTLINER

TRACTOCAMIÓN FREIGHTLINER FLD / FLD 120 84-00 MUELLE PARABÓLICA DEL. 461280

CÓDIGO	No. MAF	DESCRIPCIÓN	CANTIDAD
13038	P-208	PERNO FREIGHTLINER (# M.POWER. MP-209)	4
03010	A-26-A	ALBARDÓN FREIGHTLINER LARGO (.667 kg.)	4
85320A	85320	AMORTIGUADOR MERITOR = 65103 MONROE	2
5023	2018	PERCHA DELANTERA TRASERA PHM	2
14023	2018	PERCHA DELANTERA TRASERA	2
2122	2122	SOBRE MUELLE P/FREIGHTLINER C/TOPE DE HULE	2
PCH0034	PCH0034	PERCHA DEL.DEL.FREIGHT (5602) PHM 4013	2
06027R	RNK 254-2	BUJE BRONCE 1 1/2" x 1 1/4" x 4.00" RNK 254-2	4
06027BMR	RNK BIMETALICO	BUJE BI-METÁLICO 1 1/2" x 1 1/4" x 4.00"	4
U6G120-C	U-6G120-C	TORNILLO "U" 3/4" x 4 1/16" x 12.00"	4
20056	9054	TUERCA FINA ALTA 3/4" 8	8
18008	AR-34	RONDANA DE PRESIÓN 3/4"	8
461280F	46-1280	MUELLE COMPLETA PARABÓLICA 2 HOJAS	2

4" x .788" x 26 1/8" x 29" CON BUJES RNK
VER CATALOGO DE MUELLES MAF 2011
PARA MAS DETALLE DE ESPESORES



Garantía en Calidad y Servicio

FREIGHTLINER

TRACTOCAMIÓN FREIGHTLINER FLD / FLD 120 84-00 MUELLE PARABÓLICA DEL. 461280

PERNO FREIGHTLINER
(#M. POWER. MP-209)



CÓDIGO: 13038
No. MAF: P-208

MAF

ALBARDÓN
FREIGHTLINER LARGO
(.667kg)



CÓDIGO: 03010
No. MAF: A-26-A

MAF

AMORTIGUADOR
MONROE = 65103
MERITOR



CÓDIGO: 85320A
No. MAF: 85320

MAF

PERCHA DEL. TRAS.
FREIGHTLINER P/COL
PHM



CÓDIGO: 5023
No. MAF: 2018

MAF

SOBRE MUELLE
C/TOPE DE HULE



CÓDIGO: 2122
No. MAF: 2122

MAF

PERCHA DEL. DEL.



CÓDIGO: PCH0034
No. MAF: PCH0034

MAF

BUJE BRONCE
1 1/2" x 1 1/4" x 4.00"



CÓDIGO: 06027R
No. MAF: RNK 254-2

MAF

BUJE BI-METÁLICO
1 1/2" x 1.260" x 4.00"



CÓDIGO: 06027BMR
No. MAF: RNK
BI-METÁLICO

MAF

TORNILLO "U"
3/4" x 4 1/16" x 12.00"



CÓDIGO: U6G120-C
No. MAF: U-6G120-C

MAF

TUERCA FINA ALTA
3/4" 98



CÓDIGO: 20056
No. MAF: 9054

MAF

RONDANA DE
PRESIÓN 3/4"



CÓDIGO: 18008
No. MAF: AR-34

MAF

PERCHA DEL. TRAS.
FREIGHTLINER P/COL
CIEP



CÓDIGO: 14023
No. MAF: 2018

MAF

FREIGHTLINER
ARGOSY FL-112
MUELLE PARABÓLICA 461302F
AÑO MODELO 96-05

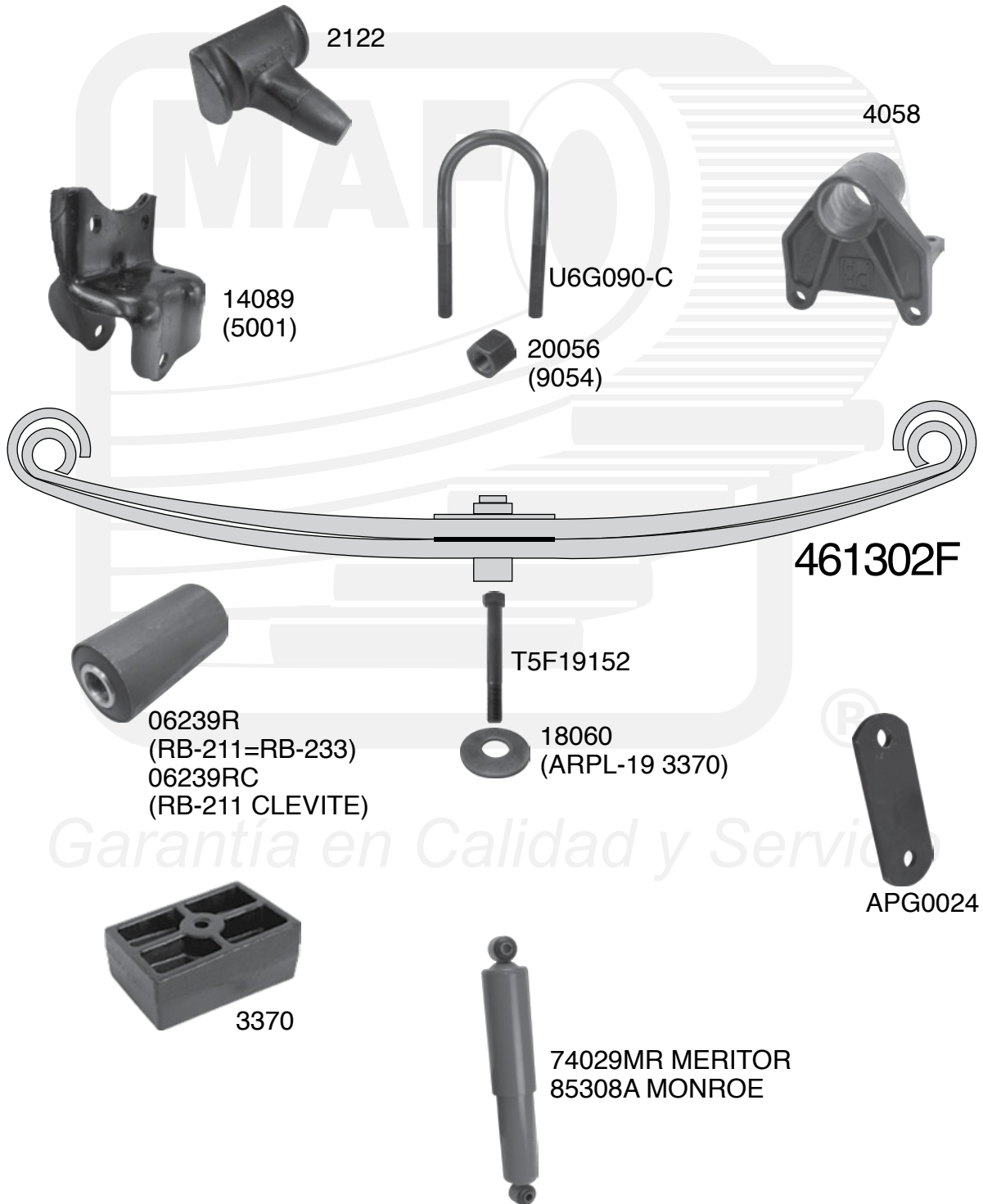

FREIGHTLINER

ARGOSY FL-112
MUELLE PARABÓLICA 461302F
AÑO MODELO 96-05

CÓDIGO	No. MAF	DESCRIPCIÓN	CANTIDAD
14089	5001	PERCHA DEL. DEL. FREIGHTLINER	2
4058	4058	PERCHA COLUMPIO PARA BUJE	2
20056	9054	TUERCA FINA ALTA DE 3/4" - 9054 °8	2
18060	ARPL-19	RONDANA PLANA DE 3/4"	2
3370	3370	CUÑA MUELLE 4" DELANTERA 5 STERLING,FTL	2
85308A	85308	AMORT. MERITOR 74029 MONROE	2
74029MR	74029	AMORT. MONROE = 85308 MERITOR	2
T5F19178	T5F19178	TORNILLO CAB. HEXAGONAL 5 NF DE 3/4" x 6.00"	4
T5F19152	T5F19152	TORNILLO CAB. HEXAGONAL 5 NF DE 3/4" x 7.00"	4
06239R	RB-211=RB-233	BUJE FIERRO Y HULE	4
2122	2122	SOBRE MUELLE P/FREIGHTLINER C/TOPE DE HULE	2
APG0024	APG0024	ALBARDÓN PLACA C	4
U6G090-C	U-6G090-C	TORNILLO "U" 3/4" x 4 1/16" x 9.00"	4
461302F	46-1302F	AMORTIGUADOR PARAB. 4.00" x .815" x 26.00" x 30.00"	2

VER CATÁLOGO DE MUELLES 2011

Garantía en Calidad y Servicio

FREIGHTLINER

ARGOSY FL-112

MUELLE PARABÓLICA 461302F

AÑO MODELO 96-05

PERCHA DEL. DEL.



CÓDIGO: 14089
No. MAF: 5001

PERCHA DEL. TRA.



CÓDIGO: 4058
No. MAF: 4058

TUERCA FINA ALTA
3/4" 08



CÓDIGO: 20056
No. MAF: 9054

RONDANA PLANA
DE 3/4"



CÓDIGO: 18060
No. MAF: ARPL-19 3370

CUÑA MUELLE 4" DEL.
05 STERLING FTL



CÓDIGO: 3370
No. MAF: 3370

AMORTIGUADOR
MONROE = 74029
MERITOR



CÓDIGO: 85308A
No. MAF: 85308

AMORTIGUADOR
MONROE = 85308
MERITOR



CÓDIGO: 74029MR
No. MAF: 74029

TORNILLO CAB HEX.
05 NF DE 3/4" x 6.00"



CÓDIGO: T5F19178
No. MAF: T5F19178

TORNILLO CAB HEX.
05 NF DE 3/4" x 7.00"



CÓDIGO: T5F19152
No. MAF: T5F19152

BUJE FIERRO Y HULE
IARSA



CÓDIGO: 06239R
No. MAF: RB-211

SOBRE MUELLE
P/FREIGHTLINER
C/TOPE DE HULE



CÓDIGO: 2122
No. MAF: 2122

ALBARDÓN
PLACA



CÓDIGO: APG0024
No. MAF: APG0024

FREIGHTLINER

ARGOSY FL-112
MUELLE PARABÓLICA 461302F
AÑO MODELO 96-05

TORNILLO "U"
3/4" x 4 1/16" x 9.00"



CÓDIGO: U6G090-C
No. MAF: U-6G090-C

MAF



Garantía de Calidad y Servicio

Características y acabados de una muelle

Funcionamiento de la muelle

Son parte de la suspensión que asegura la carrocería del vehículo con los ejes, actúa como partes estructurales posicionando al eje, tanto a lo largo como a lo ancho, en relación al bastidor (larguero) del chasis.

Absorbe los impactos como un resorte en las sacudidas en bache, topes y en carretera de terracería.

Resiste el efecto de aceleración y frenado.

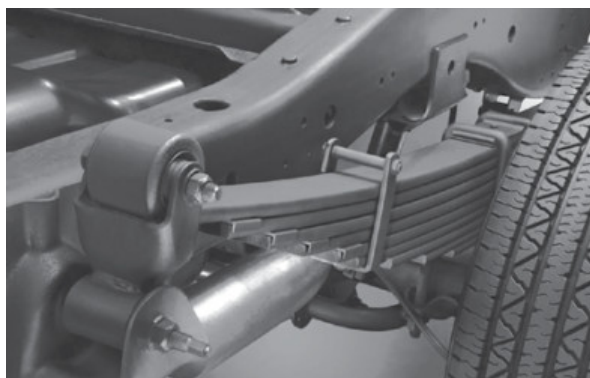

FREIGHTLINER
COLUMBIA FL-112
MUELLE PARABÓLICA 461432F
AÑO MODELO 00-05

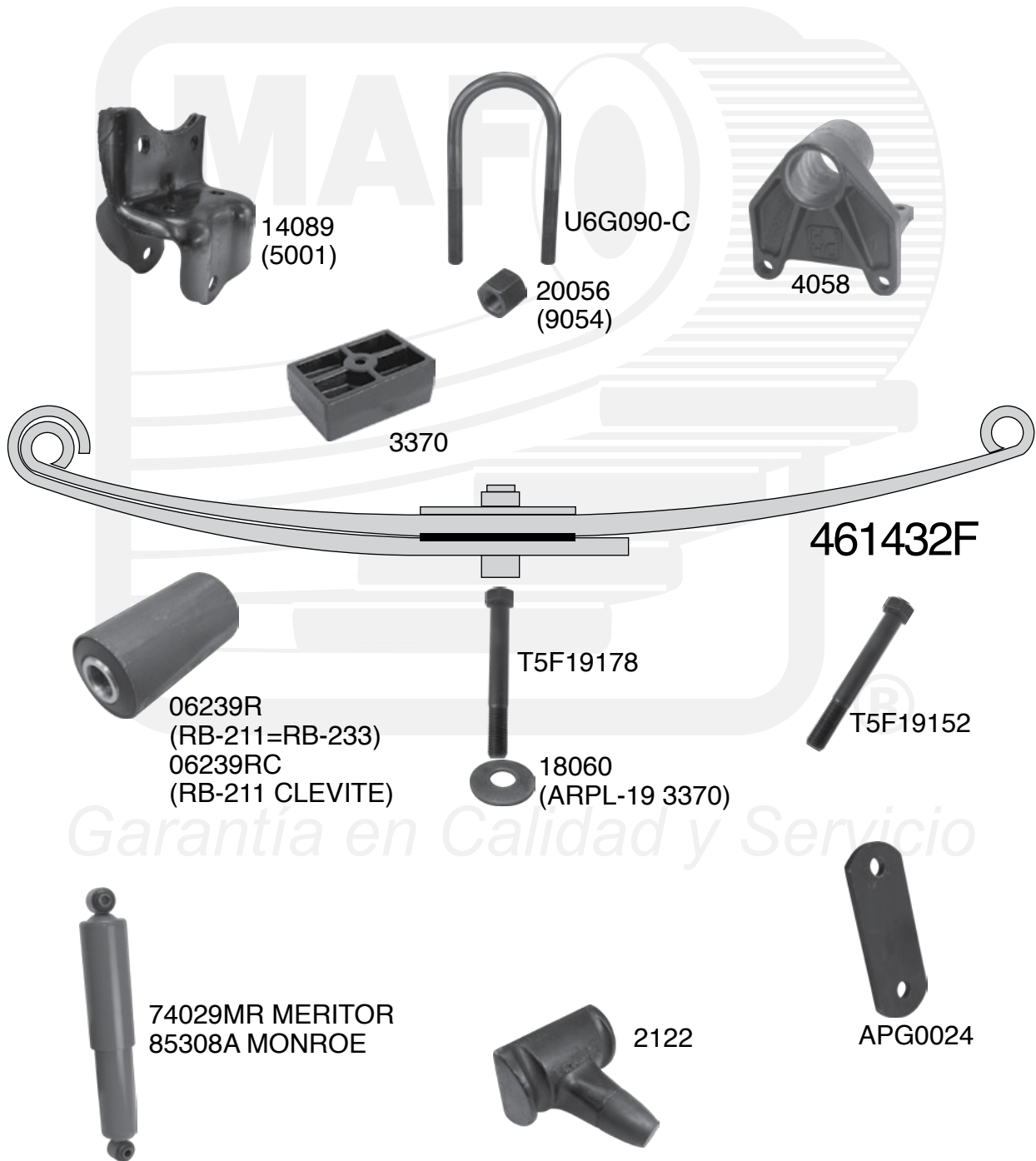

FREIGHTLINER

COLUMBIA FL-112
MUELLE PARABÓLICA 461432F
AÑO MODELO 00-05

CÓDIGO	No. MAF	DESCRIPCIÓN	CANTIDAD
14089	5001	PERCHA DEL. DEL. FREIGHTLINER	2
4058	4058	PERCHA COLUMPIO PARA BUJE	2
20056	9054	TUERCA FINA ALTA DE 3/4" 9054 °8	2
18060	ARPL-19	RONDANA PLANA DE 3/4"	2
3370	3370	CUÑA MUELLE 4" DELANTERA 5 STERLING, FTL	2
85308A	85308	AMORTIGUADOR MERITOR 74029 MONROE	2
74029MR	74029	AMORTIGUADOR MONROE = 85308 MERITOR	2
T5F19178	T5F19178	TORNILLO CAB. HEXAGONAL 5 NF DE 3/4" x 6.00"	4
T5F19152	T5F19152	TORNILLO CAB. HEXAGONAL 5 NF DE 3/4" x 7.00"	4
06239R	RB-211=RB-233	BUJE FIERRO Y HULE	4
2122	2122	SOBRE MUELLE P/FREIGHTLINER C/TOPE DE HULE	2
APG0024	APG0024	ALBARDÓN PLACA "C"	4
U6G090-C	U-6G090-C	TORNILLO "U" 3/4" x 4 1/16" x 9.00"	4
461432F	46-1432F	MUELLE PARABÓLICA 4.00" x .999" x 26.00" x 30.00"	2

VER CATÁLOGO DE MUELLES MAF 2011



Datos para el desarrollo de una muelle

Puntos a considerar

- Características del vehículo. (marca, modelo, tipo)
- Características de la muelle en forma y posición en el vehículo.
- Los componentes a usar.
- Capacidad de carga del vehículo, peso bruto vehicular.

Tomar en cuenta todos estos puntos para el buen desarrollo de una muelle de calidad.

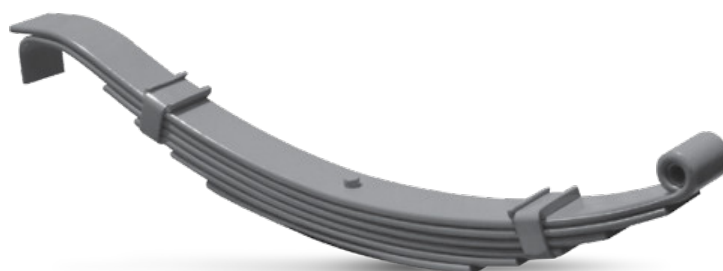

FREIGHTLINER

COLUMBIA FL-112 MUELLE PARABÓLICA 461432F AÑO MODELO 00-05

<p>PERCHA DEL. DEL.</p>  <p>CÓDIGO: 14089 No. MAF: 5001</p>	<p>PERCHA DEL. TRA.</p>  <p>CÓDIGO: 4058 No. MAF: 4058</p>	<p>TUERCA FINA ALTA 3/4" 98</p>  <p>CÓDIGO: 20056 No. MAF: 9054</p>	<p>RONDANA PLANA DE 3/4"</p>  <p>CÓDIGO: 18060 No. MAF: ARPL-19 3370</p>
<p>CUÑA MUELLE 4" DEL. 95 STERLING FTL</p>  <p>CÓDIGO: 3370 No. MAF: 3370</p>	<p>AMORTIGUADOR MONROE = 74029 MERITOR</p>  <p>CÓDIGO: 85308A No. MAF: 85308</p>	<p>AMORTIGUADOR MONROE = 85308 MERITOR</p>  <p>CÓDIGO: 74029MR No. MAF: 74029</p>	<p>TORNILLO CAB HEX. 95 NF DE 3/4" x 6.00"</p>  <p>CÓDIGO: T5F19178 No. MAF: T5F19178</p>
<p>TORNILLO CAB HEX. 95 NF DE 3/4" x 7.00"</p>  <p>CÓDIGO: T5F19152 No. MAF: T5F19152</p>	<p>BUJE FIERRO Y HULE</p>  <p>CÓDIGO: 06239R No. MAF: RB-211 CLEVITE</p>	<p>SOBRE MUELLE P/FREIGHTLINER C/TOPE DE HULE</p>  <p>CÓDIGO: 2122 No. MAF: 2122</p>	<p>ALBARDÓN PLACA</p>  <p>CÓDIGO: APG0024 No. MAF: APG0024</p>

FREIGHTLINER

COLUMBIA FL-112 MUELLE PARABÓLICA 461432F AÑO MODELO 00-05

TORNILLO "U"
3/4" x 4 1/16" x 9.00"



CÓDIGO: U6G090-C
No. MAF: U-6G090-C

MAF



Garantía de Calidad y Servicio

Esfuerzos y tensiones

Se presentan con mayor frecuencia cuando un vehículo arranca, cuando frena bruscamente, pasa baches y topes.

Vehículo estacionado soportando el peso en forma constante.

Vehículo con sobrepeso de carga.

Esto se traduce en fatiga de las hojas y muelle.

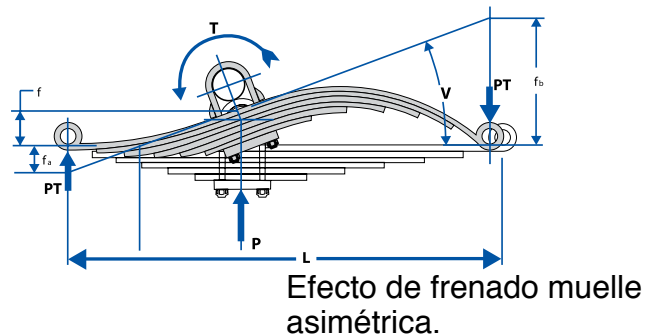
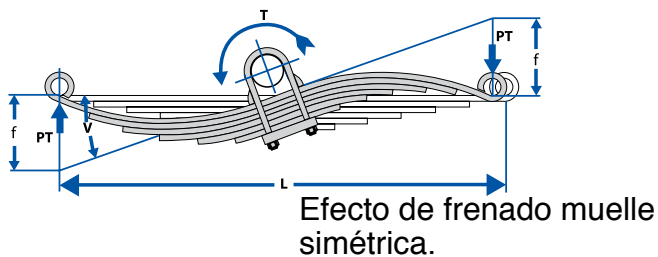

FREIGHTLINER
FL-120
MUELLE PARABÓLICA 461406F
AÑO MODELO 97-00

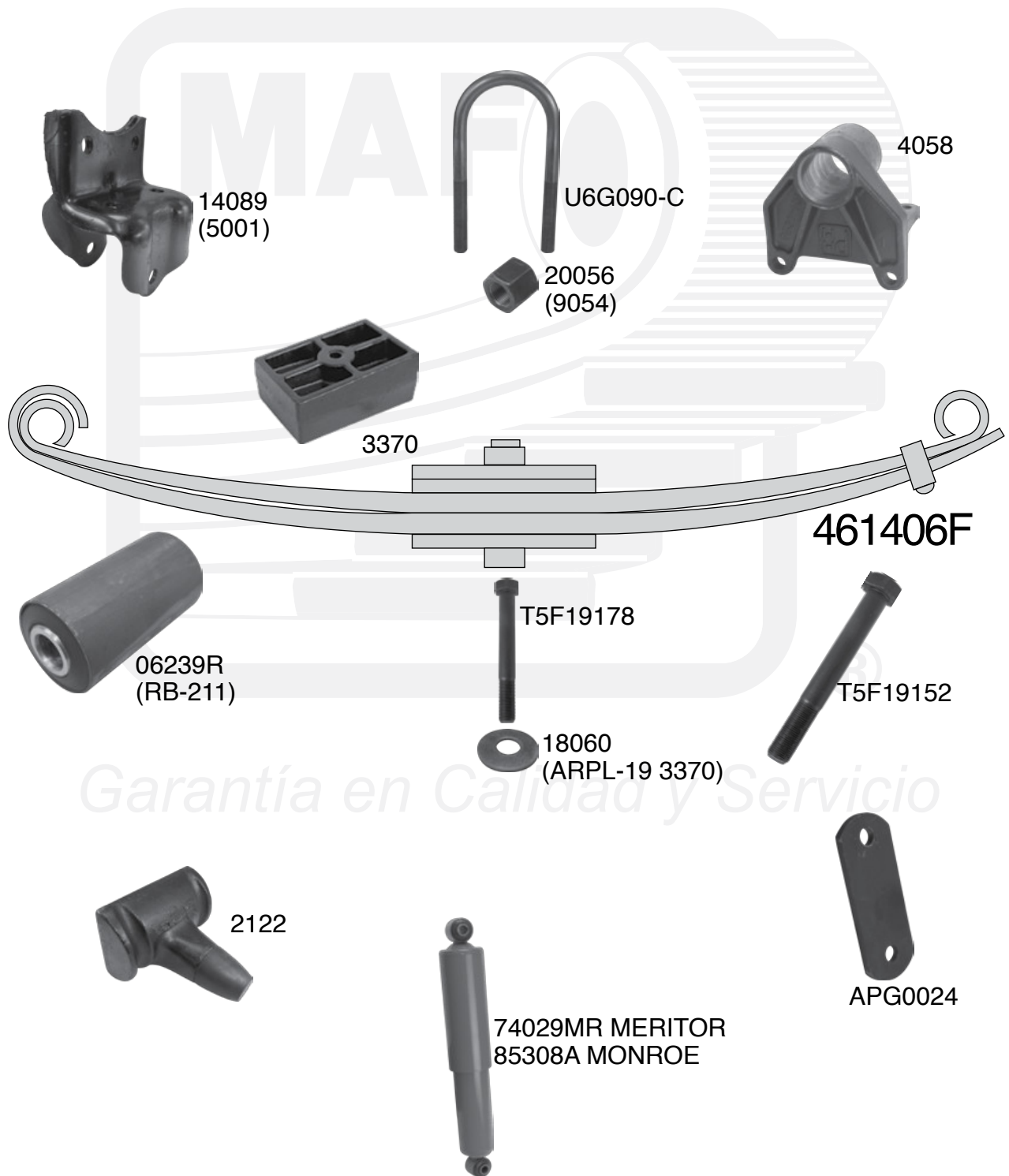

FREIGHTLINER

FL-120
MUELLE PARABÓLICA 461406F
AÑO MODELO 97-00

CÓDIGO	No. MAF	DESCRIPCIÓN	CANTIDAD
14089	5001	PERCHA DEL. DEL. FREIGHTLINER	2
4058	4058	PERCHA COLUMPIO PARA BUJE	2
20056	9054	TUERCA FINA ALTA DE 3/4" - 9054 °8	2
18060	ARPL-19	RONDANA PLANA DE 3/4"	2
3370	3370	CUÑA MUELLE 4" DELANTERA 5 STERLING FTL	2
85308A	85308	AMORTIGUADOR MERITOR 74029 MONROE	2
74029MR	74029	AMORTIGUADOR MONROE = 85308 MERITOR	2
T5F19178	T5F19178	TORNILLO CAB. HEXAGONAL 5 NF DE 3/4" x 6.00"	4
T5F19152	T5F19152	TORNILLO CAB. HEXAGONAL 5 NF DE 3/4" x 7.00"	4
06239R	RB-211=RB-233	BUJE FIERRO Y HULE	4
2122	2122	SOBRE MUELLE P/FREIGHTLINER C/TOPE DE HULE	2
APG0024	APG0024	ALBARDÓN PLACA "C"	4
U6G090-C	U-6G090-C	TORNILLO "U" 3/4" x 4 1/16" x 9.00"	4
461406F	46-1406F	MUELLE PARABÓLICA. 4.00" x .815" x 26.00" x 30.00"	2

VER CATÁLOGO DE MUELLES MAF 2011

Garantía en Calidad y Servicio

FREIGHTLINER

FL-120 MUELLE PARABÓLICA 461406F AÑO MODELO 97-00

<p>PERCHA DEL. DEL.</p>  <p>CÓDIGO: 14089 No. MAF: 5001</p>	<p>PERCHA DEL. TRA.</p>  <p>CÓDIGO: 4058 No. MAF: 4058</p>	<p>TUERCA FINA ALTA 3/4" 98</p>  <p>CÓDIGO: 20056 No. MAF: 9054</p>	<p>RONDANA PLANA DE 3/4"</p>  <p>CÓDIGO: 18060 No. MAF: ARPL-19 3370</p>
<p>CUÑA MUELLE 4" DEL. °5 STERLING FTL</p>  <p>CÓDIGO: 3370 No. MAF: 3370</p>	<p>AMORTIGUADOR MONROE = 74029 MERITOR</p>  <p>CÓDIGO: 85308A No. MAF: 85308</p>	<p>AMORTIGUADOR MONROE = 85308 MERITOR</p>  <p>CÓDIGO: 74029MR No. MAF: 74029</p>	<p>TORNILLO CAB HEX. °5 NF DE 3/4" x 6.00"</p>  <p>CÓDIGO: T5F19178 No. MAF: T5F19178</p>
<p>TORNILLO CAB HEX. °5 NF DE 3/4" x 7.00"</p>  <p>CÓDIGO: T5F19152 No. MAF: T5F19152</p>	<p>BUJE FIERRO Y HULE</p>  <p>CÓDIGO: 06239R No. MAF: RB-211</p>	<p>SOBRE MUELLE P/FREIGHTLINER C/TOPE DE HULE</p>  <p>CÓDIGO: 2122 No. MAF: 2122</p>	<p>ALBARDÓN PLACA</p>  <p>CÓDIGO: APG0024 No. MAF: APG0024</p>

FREIGHTLINER

FL-120
MUELLE PARABÓLICA 461406F
AÑO MODELO 97-00



Principales causas de fatiga de una muelle

- ① **El exceso de carga repercute en la fatiga**
- ② **Amortiguadores en mal estado**

Cuanto mayor sea la carga del vehículo y la muelle se deforme irregularmente. Menor será su ciclo de vida



El mal funcionamiento del amortiguador aumentará la fatiga de la muelle. Cuando el amortiguador está en malas condiciones el vehículo tiende a golpetear. Esto hace que baje el rendimiento y funcionamiento de la muelle.

- ③ **Frenos mal ajustados**

El mal ajuste de los frenos también puede reducir la vida de la muelle. Al frenar en forma irregular, la muelle absorbe parte de las fuerzas de frenado.

FREIGHTLINER

FREIGHTLINER REVOLVEDORA

MUELLE FRET156

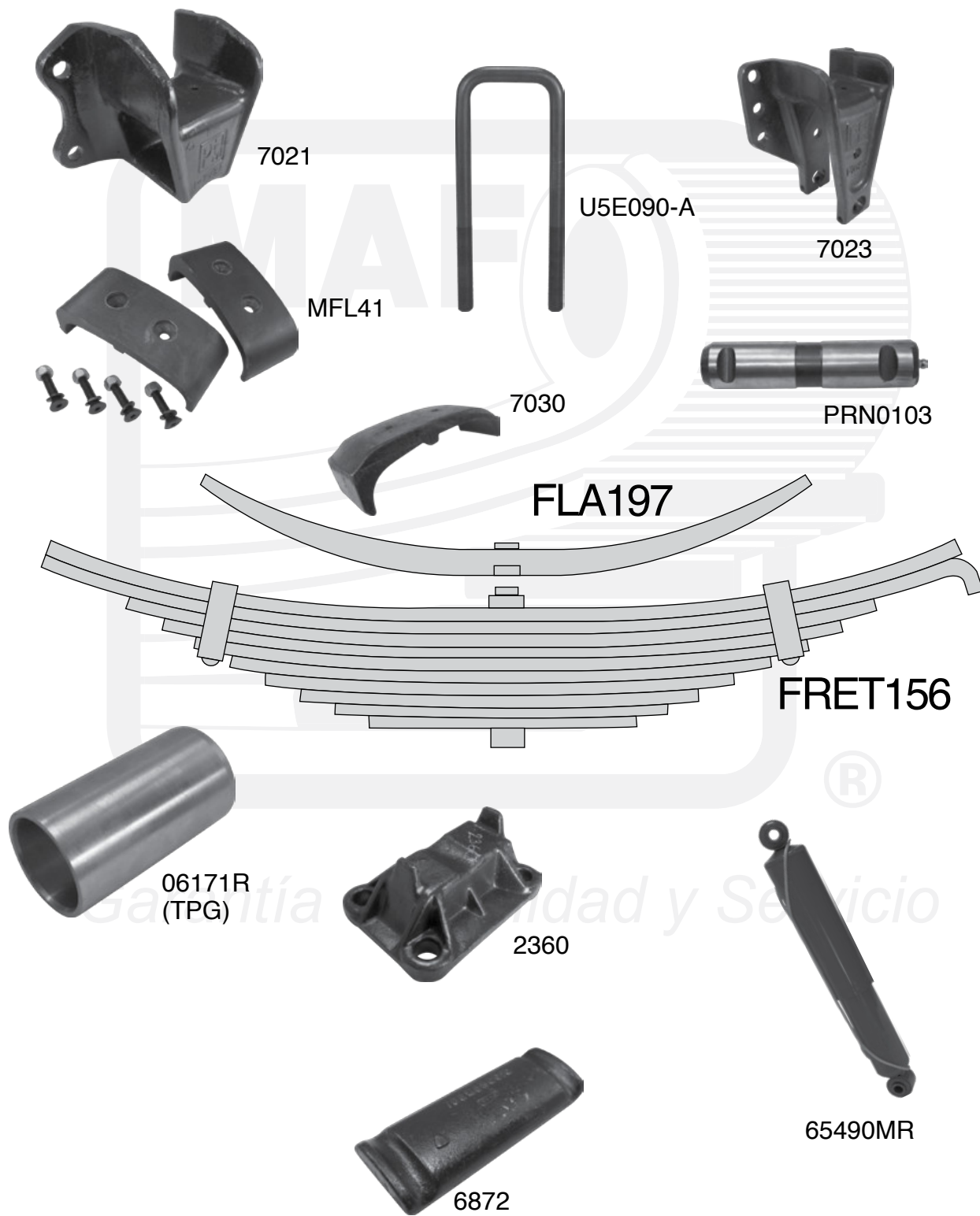

FREIGHTLINER

FREIGHTLINER REVOLVEDORA
MUELLE FRET156

CÓDIGO	No. MAF	DESCRIPCIÓN	CANTIDAD
2360	2360	TAPA INFERIOR FREIGHTLINER	2
65490MR	65490	AMORTIGUADOR MONROE = 85724 MERITOR	2
06171R	TPG	BUJE BRONCE 1 5/8" x 1 3/8" x 3.00"	2
6872	6872	ASIENTO ABRAZADERA	2
MFL41	MFL41	KIT PAD DESLIZANTE	2
7030	7030	PAD DESLIZANTE	2
7021	7021	PERCHA TRASERA TRASERA	2
U5E090-A	U-5E090-A	TORNILLO "U" 5/8" x 3 1/16" x 9.00"	4
7023	7023	PERCHA TRASERA DELANTERA	2
PRN0103	PRN0103	PERNO P/TIRANTE 1 3/8" P/SUSPENSIÓN	2
FRET156	FRET156	MUELLE DE 10 HOJAS	2
		HOJA01 3" x .625 x 29 1/2" x 29 1/2"	

VER CATÁLOGO DE MUELLES MAF 2011



Garantía en Calidad y Servicio

FREIGHTLINER

FREIGHTLINER REVOLVEDORA MUELLE FRET156

TAPA INFERIOR



CÓDIGO: 2360
No. MAF: 2360

AMORTIGUADOR
MONROE = 83317
MERITOR



CÓDIGO: 65490MR
No. MAF: 65490

BUJE BRONCE
1 5/8" x 1 3/8" x 3.00"



CODIGO: 06171R
No. MAF: TPG

ASIENTO
ABRAZADERA



CÓDIGO: 6872
No. MAF: 6872

KIT PAD
DESLIZANTE



CÓDIGO: MLF41
No. MAF: MLF41

PAD
DESLIZANTE



CÓDIGO: 7030
No. MAF: 7030

PERCHA TRAS. TRAS.



CÓDIGO: 7021
No. MAF: 7021

TORNILLO "U"
5/8" x 3 1/16" x 9.00"



CÓDIGO: U5E090-A
No. MAF: U-5E090-A

PERCHA TRAS. DEL.



CÓDIGO: 7023
No. MAF: 7023

PERNO P/TIRANTE
1 3/8 P/SUSP.



CÓDIGO: PRN0103
No. MAF: PRN0103

Garantía Calidad y Servicio

FORD

FORD RANGER
MODELO 98-2001 FT307

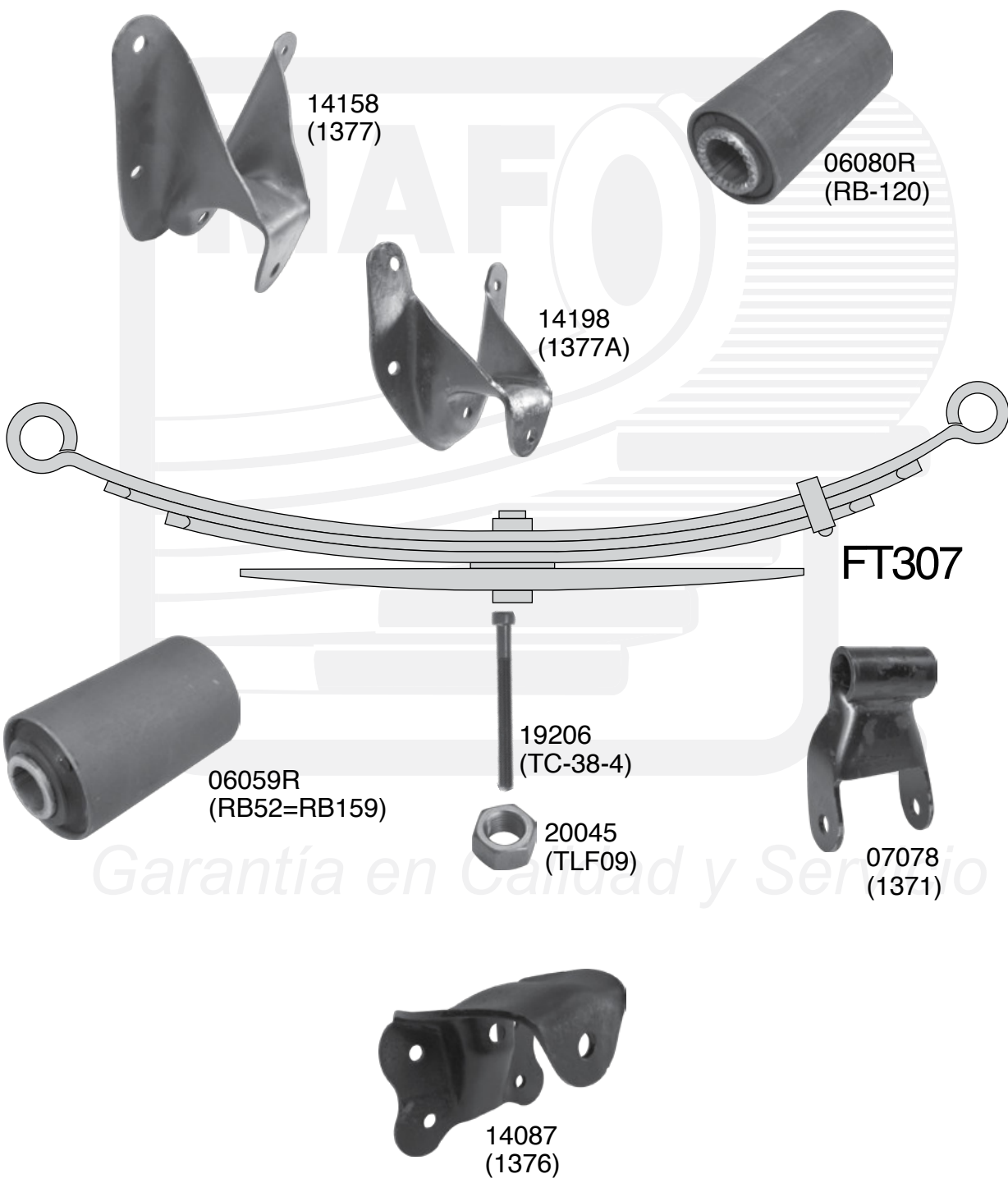

Garantía en Calidad y Servicio

FORD RANGER
 MODELO 98-2001 FT307

CÓDIGO	No. MAF	DESCRIPCIÓN	CANTIDAD
14198	1377A	TRAS. DEL. FORD RANGER AMERICANO	2
14158	1377	PERCHA TRAS.DEL. RANGER NACIONAL	2
14087	1376	PERCHA TRASERA TRASERA	2
07078	1371	COLUMPIO 2000-2003	2
06080R	RB-120	BUJE FIERRO Y HULE RB-120	2
06059R	RB-52-A=RB-159	BUJE FIERRO Y HULE RB-52-A=RB-159	2
20045	TLF09	TUERCA FINA ALTA DE 5/8" °2	2
19206	TC-38-4	TORNILLO DE CENTRO 3/8" x 4"	2
FT307	FT-307	MUELLE COMPLETA FT 307, 4 HOJAS	2
		HOJA 1ra 2 1/2" x .323" x 23 3/4" x 31"	

VER CATÁLOGO DE MUELLES MAF 2011



Mantenimiento de las muelles









Recomendaciones

Garantía en Calidad y Servicio

- Mantener los bujes de bronce, roscados, engrasados y en buen estado.
- Revisar que los bujes de hule-metal esten trabajando correctamente, cuidando que no tenga contacto el tubo interior con el rol de la muelle.
- No es recomendable reutilizar los Tornillos "U".
- Asientos de eje, placas superiores y otros componentes deben ser inspeccionados periódicamente y sustituidos cuando sea necesario.
- Revisar las muelles y componentes al menos cada 50,000 km. para observar que no haya fisuras en las hojas o componentes dañados.
- Por último, un mantenimiento inadecuado afecta la duración de la muelle.

FORD

FORD RANGER MODELO 98-2001 FT307

<p>PERCHA TRAS. DEL.</p>  <p>CÓDIGO: 14198 No. MAF: 1377A</p>	<p>PERCHA TRAS. DEL.</p>  <p>CÓDIGO: 14158 No. MAF: 1377</p>	<p>PERCHA TRAS. TRAS.</p>  <p>CÓDIGO: 14087 No. MAF: 1376</p>	<p>COLUMPIO</p>  <p>CÓDIGO: 07078 No. MAF: 1371</p>
<p>BUJE FIERRO Y HULE RB-52</p>  <p>CÓDIGO: 06059R No. MAF: RB52/RB159</p>	<p>BUJE FIERRO Y HULE RB-120</p>  <p>CÓDIGO: 06080R No. MAF: RB120</p>	<p>TORNILLO CENTRO DE 3/8" x 6"</p>  <p>CÓDIGO: 19206 No. MAF: TC-38-4</p>	<p>TUERCA UNF. °2 DE 3/8"</p>  <p>CÓDIGO: 20045 No. MAF: TLF09</p>

Garantía en Calidad y Servicio

FORD

FORD LOBO PICK UP
 MODELO 98- 2001 FT692

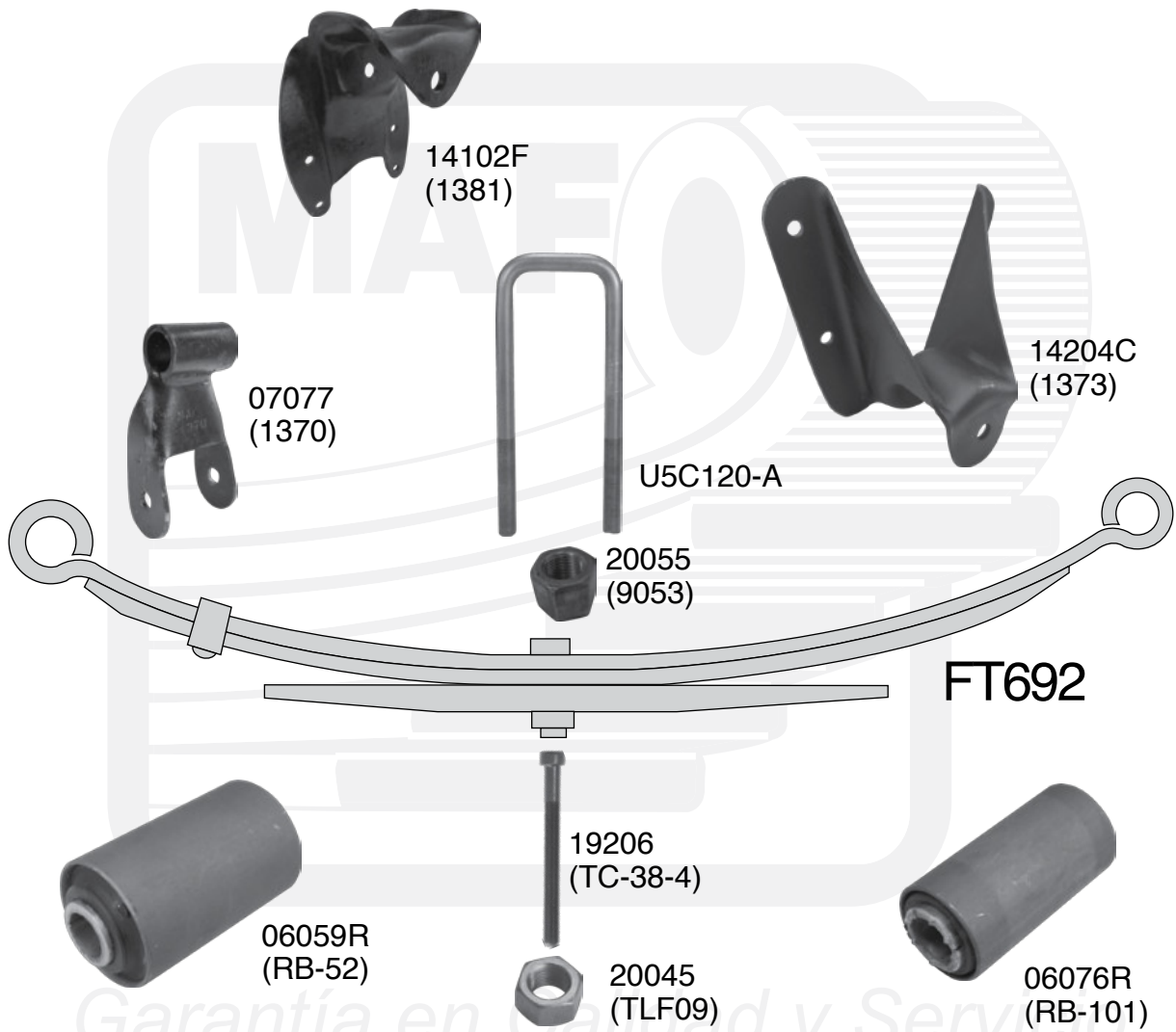

Garantía en Calidad y Servicio

FORD

FORD LOBO PICK UP MODELO 98- 2001 FT692

CÓDIGO	No. MAF	DESCRIPCIÓN	CANTIDAD
07077	1370	COLUMPIO	2
14102F	1381	PERCHA TRASERA TRASERA	2
14204C	1373	PERCHA TRASERA DELANTERA	2
06076R	RB-101=RB-156	BUJE FIERRO Y HULE	2
06059R	RB-52-A=RB-159	BUJE FIERRO Y HULE	2
06338R	RB-181CC	BUJE FIERRO Y HULE	2
20055	9053	TUERCA FINA ALTA DE 5/8" 9053 °8	2
19206	TC-38-4	TORNILLO DE CENTRO 3/8" x 4"	2
20045	TLF09	TUERCA FINA DE 3/8 °8	2
U5C120-A	U-5C120-A	TORNILLO "U" 5/8" x 2 5/16" x 12.00"	2
FT692	FT-692	MUELLE COMPLETA FT692, 3 HOJAS	
		HOJA 1ra 2 1/2" x .360" x 26 1/2" x 32"	

VER CATÁLOGO DE MUELLES MAF 2011



Muelles de Calidad

Generalidades

En una muelle las hojas deben estar adecuadamente alineadas una con respecto a las otras hojas. Tanto en forma lateral como en forma vertical.



Escalonamiento correcto



Hojas 2da Corta



Hojas largas

Las hojas en las muelles deben estar juntas entre ellas, no deben tener claros.

El escalonamiento entre las hojas debe ser proporcional al número de hojas que está compuesta la muelle.

La superficie área tensión con compresión, tiene que tener contacto uniformemente; evitar puntos de contacto de esfuerzo.

FORD

FORD LOBO PICK UP MODELO 98- 2001 FT692

COLUMPIO



CÓDIGO: 07077
No. MAF: 1370

MAF

PERCHA TRAS. TRAS.



CÓDIGO: 14102F
No. MAF: 1381

MAF

PERCHA TRAS. DEL.



CÓDIGO: 14204C
No. MAF: 1373

MAF

BUJE FIERRO Y HULE
RB-101 = RB-159



CÓDIGO: 06076R
No. MAF: RB-101

MAF

BUJE FIERRO Y HULE
RB-52-A



CÓDIGO: 06059R
No. MAF: RB-52-A

MAF

TORNILLO CENTRO
3/8" x 4"



CÓDIGO: 19206
No. MAF: TC-38-4

MAF

TUERCA UNF
°8 DE 3/8"



CÓDIGO: 20045
No. MAF: TLF09

MAF

TUERCA UNF
°8 DE 3/8"



CÓDIGO: 20055
No. MAF: TLF09

MAF

TORNILLO U
5/8" x 2 5/16" x 12.00"



CÓDIGO: U5C120-A
No. MAF: U-5C120-A

MAF

Garantía en Calidad y Servicio

FORD

FORD F-350
MODELO 66 -94 FT487R

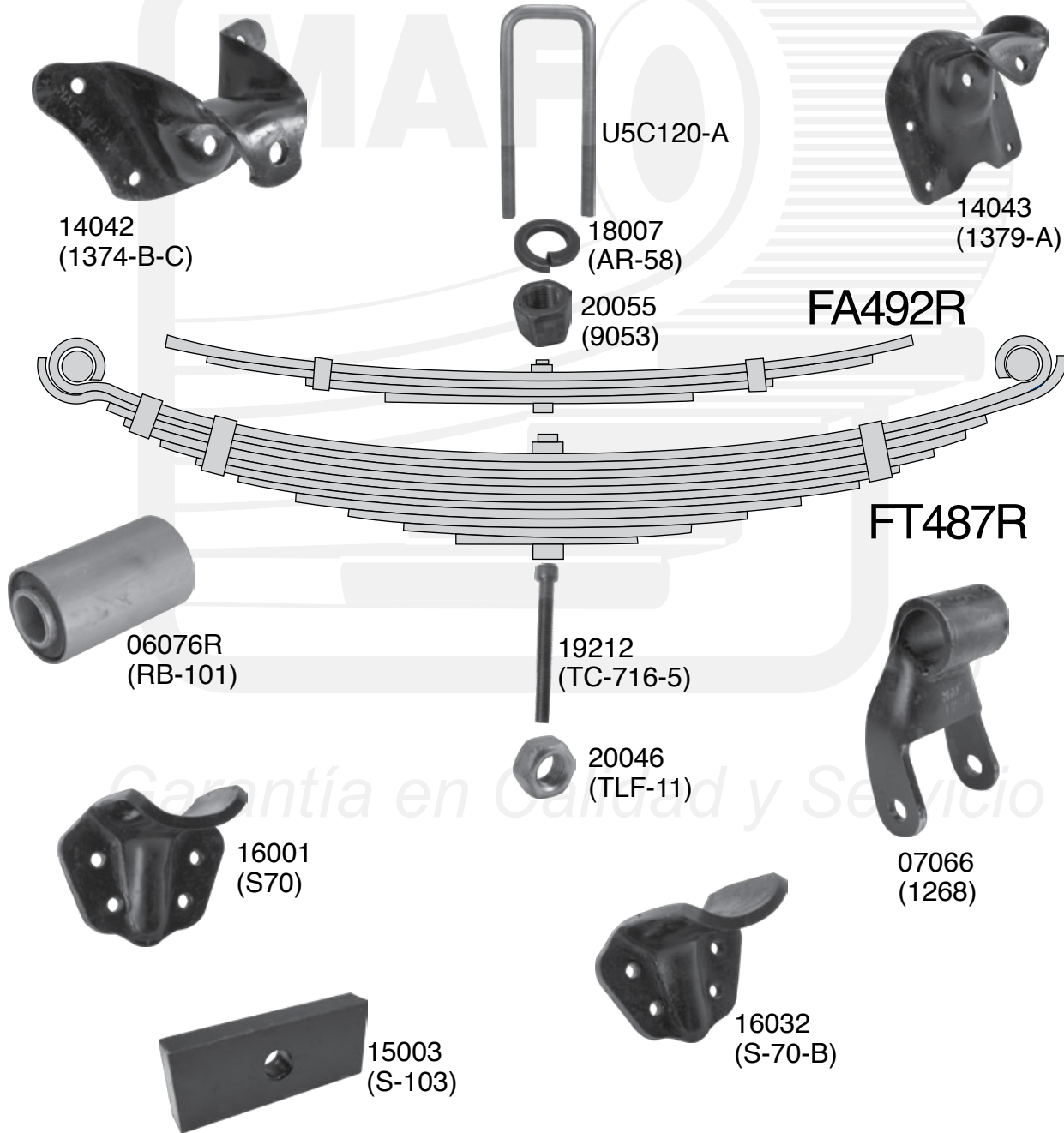

FORD

FORD F-350
MODELO 66 -94 FT487R

FORD

lista de partes

CÓDIGO	No. MAF	DESCRIPCIÓN	CANTIDAD
14042	1374-B-C	PERCHA TRAS. DEL.	2
14043	1379-A	PERCHA TRAS. TRAS.	2
U5C120-A	U-5C120-A	TORNILLO "U" 5/8" x 2 5/16" x 12.00"	4
16001	S-70	SOPORTE F-350	4
16032	S-70-B	SOPORTE PATA LARGA	4
07066	1268	COLUMPIO F-350	2
15003	S-103	SEPARADOR 2 1/4" x 5 1/2" x 7/8"	2
06076R	RB-101=RB-156	BUJE FIERRO Y HULE	4
19212	TC-716-5	TORNILLO DE CENTRO 7/16" x 5.00"	2
20046	TLF11	TUERCA UNF. DE 7/16" °2	2
20055	9053	TUERCA FINA ALTA DE 5/8" - °8	8
18007	AR-58	RONDANA DE PRESIÓN 5/8"	8
FT487R	FT-487R	MUELLE COMPLETA FT-487R, 10 HOJAS	8
		HOJA 1ra 2 1/4" x .323 "x 26"x 26"	2
FA492R	FA-492R	MUELLE AUXILIAR 4 HOJAS	
		HOJA-01 2 1/4" x .323" x 20 3/4" x 20 3/4"	2

VER CATÁLOGO DE MUELLES MAF 2011



Garantía en Calidad y Servicio

FORD

FORD F-350 MODELO 66 -94 FT487R

PERCHA F350 MICRO
MOD. 66/94



CÓDIGO: 14042
No. MAF: 1374-B-C

MAF

TORNILLO "U"
5/8" x 2 5/16" x 12.00



CÓDIGO: U5C120-A
No. MAF: U-5C120-A

MAF

SOPORTE F350



CÓDIGO: 16001
No. MAF: S-70

MAF

PERCHA F350
MOD 66/88



CÓDIGO: 14043
No. MAF: 1379-A

MAF

TORNILLO DE CENTRO
7/16" X 5.00"



CÓDIGO: 19212
No. MAF: TC-716-5

MAF

TUERCA FINA ALTA
5/8" 08



CÓDIGO: 20055
No. MAF: 9053

MAF

SOPORTE
PATA LARGA



CÓDIGO: 16032
No. MAF: S-70-B

MAF

SERAPADOR
2 1/4" x 5 1/2" x 7/8



CÓDIGO: 15003
No. MAF: S-103

MAF

COLUMPIO F350



CÓDIGO: 07066
No. MAF: 1268

MAF

TUERCA UNF
7/16" 02



CÓDIGO: 20046
No. MAF: TLF11

MAF

RONDANA DE
PRESIÓN 5/8"



CÓDIGO: 18007
No. MAF: AR-58

MAF

Partes para quinta rueda



XA7802



HOL052



TKW0039
TKW0041



RK351AL



PRN0051
PERNO REY

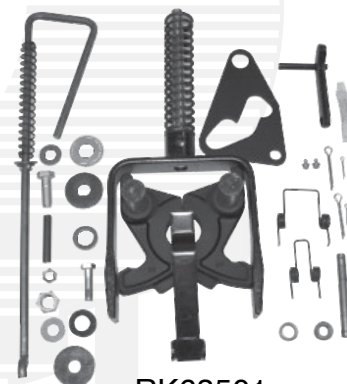

RK63501



RK63503

RK35107296



FON002



FON003



FON005
FON004

Para mayor información consulte al ejecutivo de ventas

FORD

FORD F-450 F-550
MODELO SUPER DUTY
AÑO 1999 FDP450

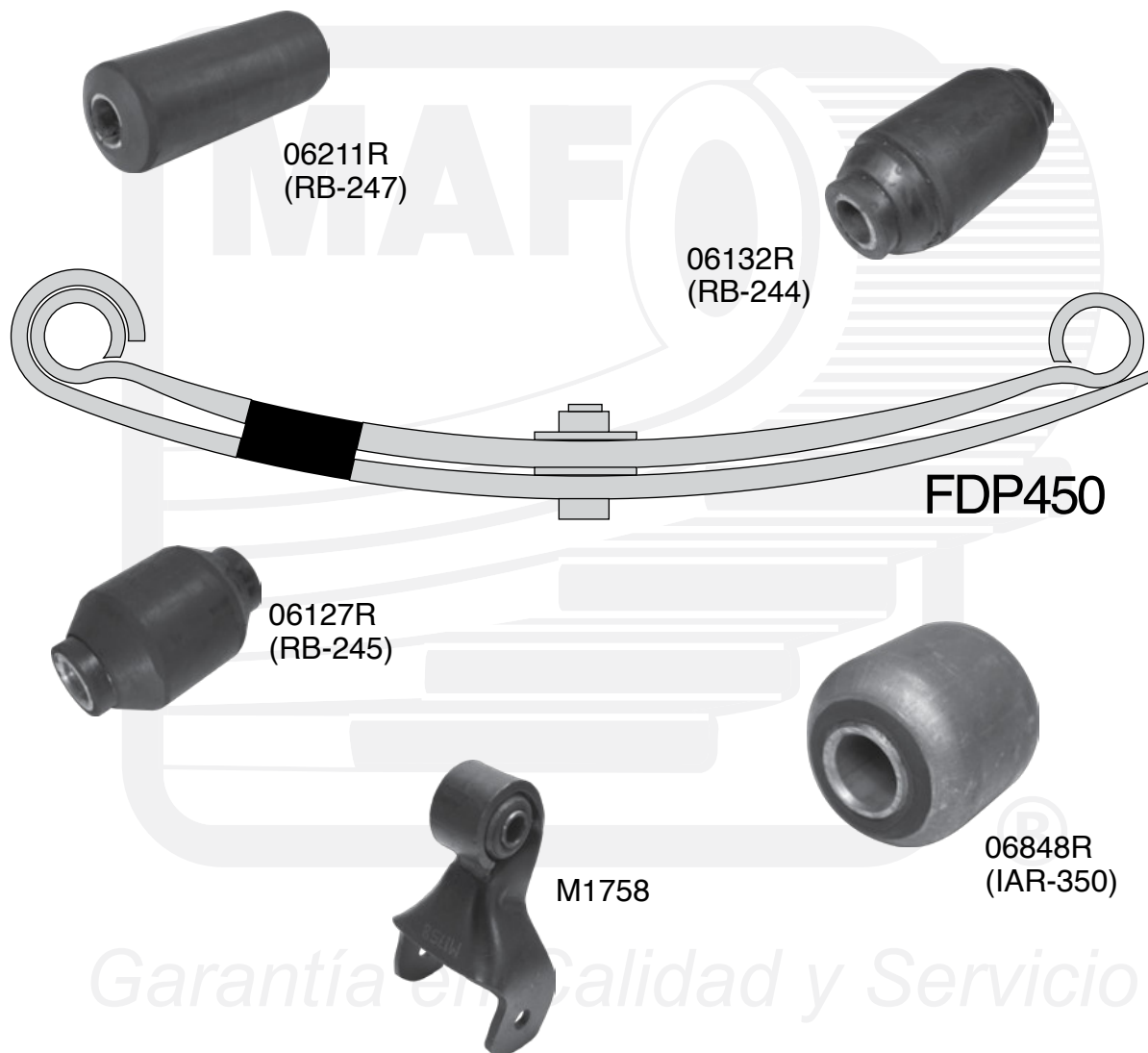

FORD

FORD F-450 F-550
 MODELO SUPER DUTY
 AÑO 1999 FDP450

FORD

lista de partes

CÓDIGO	No. MAF	DESCRIPCIÓN	CANTIDAD
06211R	RB-247	BUJE FIERRO Y HULE	2
06132R	RB-244	BUJE FIERRO Y HULE	2
06127R	RB245	BUJE FIERRO Y HULE	2
06848R	IAR-350	BUJE F. Y GOMA P/COLUMPIO DELANTERO	4
M1758	M1758	COLUMPIO F450 SUPER DUTY 97-04 C/BUJE	4
FDP450	FDP-450	SEMI-PARABÓLICA 3" x .625" x 27 1/2" x 28"	2
FDP451	FDP-451	SEMI-PARABÓLICA 3" x .625" x 27 1/2" x 28 1/2"	2
43778F	43-778	PARABÓLICA 3" x .625" x 27 1/2" x 28 1/8"	2
43804F	43-804F	PARABÓLICA 3" x .625" x 27 1/2" x 28 1/8"	2

VER CATÁLOGO DE MUELLES MAF 2011



Muelles de Calidad

Características que cumplen las especificaciones

Garantía en Calidad y Servicio

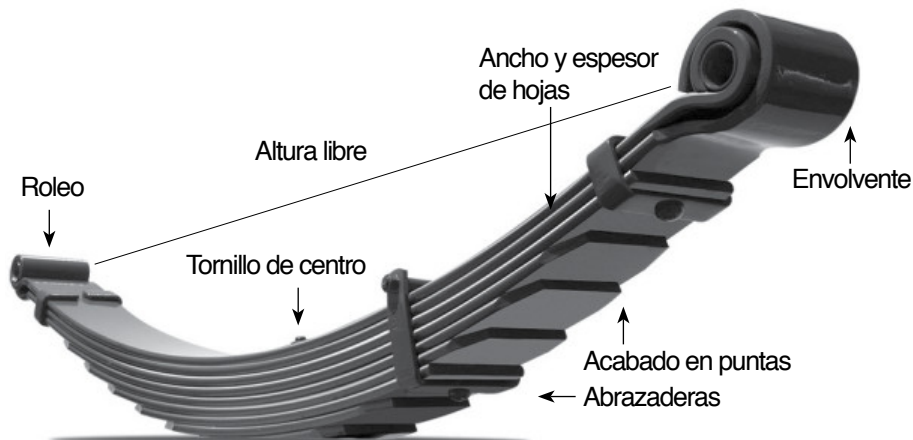

FORD

FORD F-450 F-550 MODELO SUPER DUTY AÑO 1999 FDP450

BUJE FIERRO Y HULE



CÓDIGO: 06211R
No. MAF: RB-247

MAF

BUJE FIERRO Y HULE



CÓDIGO: 06132R
No. MAF: RB-244

MAF

BUJE FIERRO Y GOMA
P/COLUMPIO DEL.



CÓDIGO: 06848R
No. MAF: IAR-350

MAF

COLUMPIO F450
SUPER DUTY 97/04
C/BUJE



CÓDIGO: M1758
No. MAF: M1758

MAF

BUJE FIERRO Y HULE



CÓDIGO: 06127R
No. MAF: RB-245

MAF

Garantía en Calidad y Servicio

FORD

FORD F-450 - F550
 MODELO 99-02
 MUELLE FT450

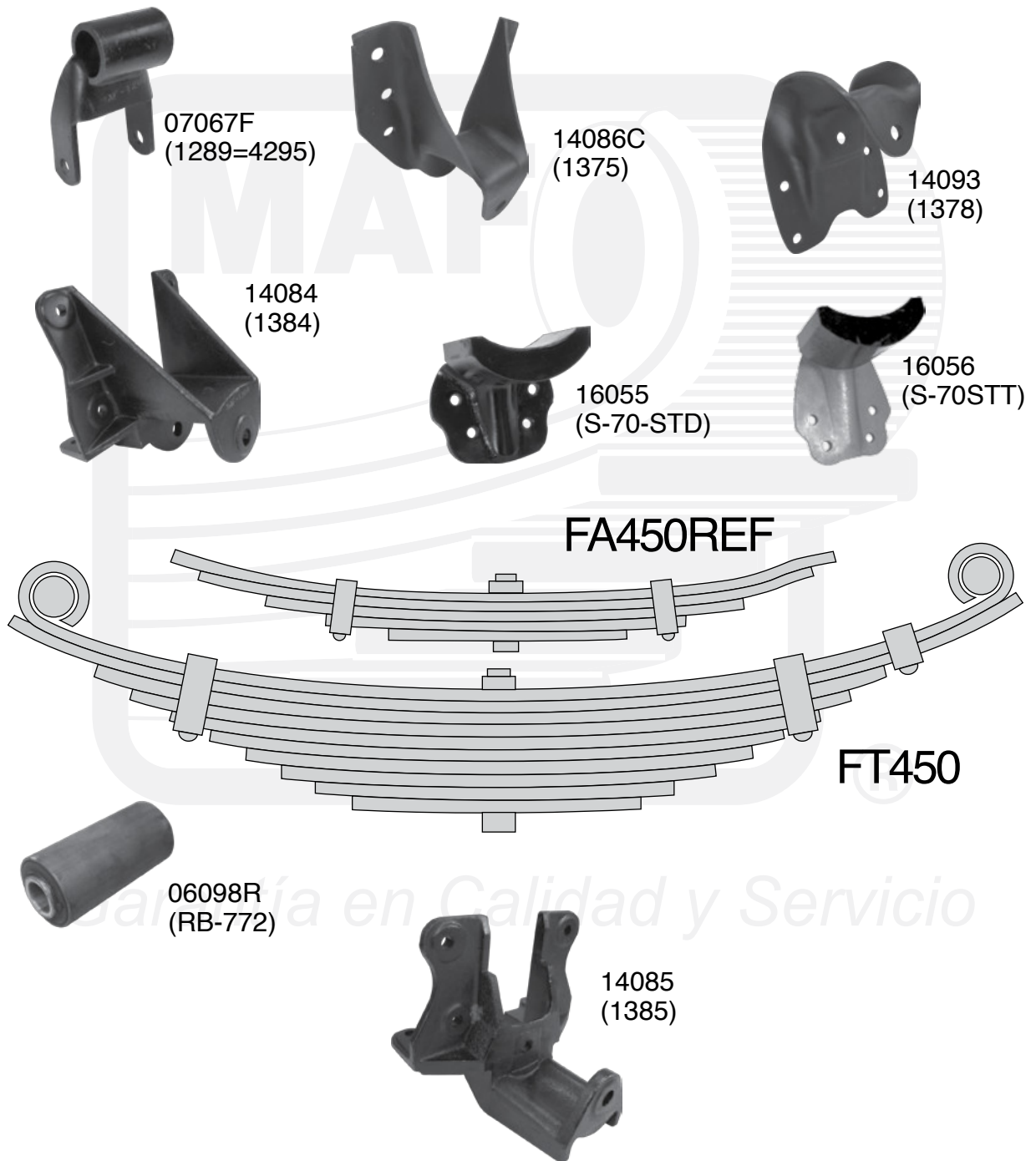

FORD

FORD F-450 - F550 MODELO 99-02 MUELLE FT450

CÓDIGO	No. MAF	DESCRIPCIÓN	CANTIDAD
4021	4021	PERCHA TRASERA TRASERA PHM	2
14093	1378	PERCHA TROQUELADA TRAS. TRAS. MAF	2
14085	1385	PERCHA FUNDICIÓN TRASERA DEL. MAF	2
07067F	1289=4295	COL. FORD S/DUTY=4295 HEAVY DUTY S/B 96/00	2
06098R	RB-772	BUJE FIERRO Y HULE	4
16056	S-70-STT	SOPORTE VULCANIZADO TRASERO	2
16055	S-70-STD	SOPORTE VULCANIZADO DELANTERO	2
4029	4029	PERCHA TRASERA DELANTERA PHM	2
14086C	1375	PERCHA TRAS. DEL. TROQUELADA	2
14084	1384	PERCHA TRASERA DELANTERA MAF	2
FT450	FT-450	MUELLE DE 10 HOJAS	2
		HOJA01 3" x .401" x 25" x 30"	
FA450REF	FA-450 REF	MUELLES AUXILIAR 5 HOJAS	2
		HOJA -01 3" x .360" x 20" x 22"	



Bolsas de aire

Productos MAF para otras aplicaciones



FORD

FORD F-450 - F550 MODELO 99-02 MUELLE FT450

<p>PERCHA TRAS. DEL. PHM</p>  <p>CÓDIGO: 4021 No. MAF: 4021</p> <p>MAF</p>	<p>PERCHA TRAS. TRAS. TROQUELADA.</p>  <p>CÓDIGO: 14093 No. MAF: 1378</p> <p>MAF</p>	<p>PERCHA TRAS. DEL. MAF</p>  <p>CÓDIGO: 14085 No. MAF: 1385</p> <p>MAF</p>	<p>COLUMPIO</p>  <p>CÓDIGO: 07067F No. MAF: 1289=4295</p> <p>MAF</p>
<p>BUJE FIERRO Y HULE</p>  <p>CÓDIGO: 06098R No. MAF: RB-772</p> <p>MAF</p>	<p>(VULCANIZ.) FORD SUPER DUTY F450 98/04</p>  <p>CÓDIGO: 16056 No. MAF: S-70-STT</p> <p>MAF</p>	<p>(VULCANIZ.) FORD SUPER DUTY F450 98/04</p>  <p>CÓDIGO: 16055 No. MAF: S-70-STT</p> <p>MAF</p>	<p>PERCHA PARTE FIJA PHM</p>  <p>CÓDIGO: 4029 No. MAF: 4029</p> <p>MAF</p>
<p>PERCHA TRAS. DEL. TROQUELADA.</p>  <p>CÓDIGO: 14086C No. MAF: 1375</p> <p>MAF</p>	<p>PERCHA FUNDICIÓN MAF</p>  <p>CÓDIGO: 14084 No. MAF: 1384</p> <p>MAF</p>	<p>Calidad y Servicio</p>	

FORD

FORD F-600/B600
MODELO 62-79 MUELLE FT351



14040F
(1367)



16003
(S-71)



14038F
(1366)



14047F
(1383)



U6E150-C
U6E170-C
U6E190-C
U7E190-C



14045F
(1382)



5029

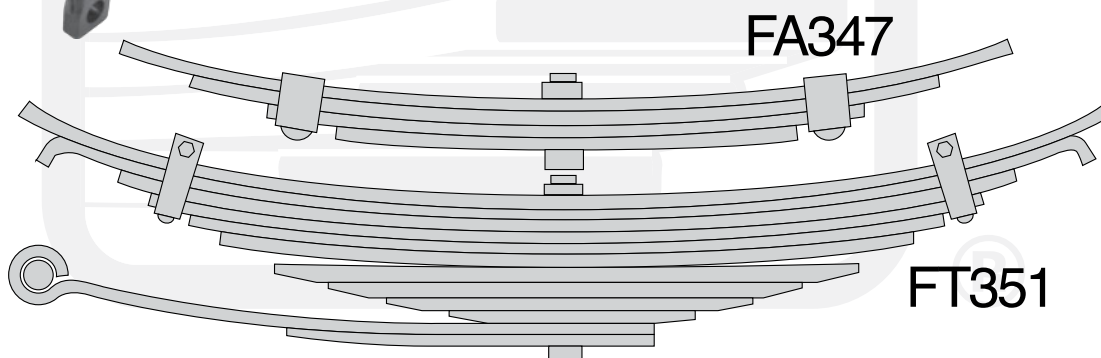

FA347

FT351

Garantía en Calidad y Servicio



2153



06021R
06021BMR
RNG



6001



5030



13104
(P-144-A)



2358



65102MR



85001A

FORD

FORD F-600/B600 MODELO 62-79 MUELLE FT351

CÓDIGO	No. MAF	DESCRIPCIÓN	CANTIDAD
6001	6001	TACÓN SEPARADOR	2
2358	2358	SEPARADOR DE MUELLES 3/4" x 2 1/2" x 5 1/2"	2
85001A	85001A	AMORTIGUADOR MERITOR	2
65102MR	65102	AMORTIGUADOR MONROE=85001 - 85305- 89410	2
14047F	1383-A=2051	PERCHA F600 / B600 DERECHA	4
14045F	1382-A=2050	PERCHA F600 / B600 IZQUIERDA	4
13104	P-144-A	PERNO FORD	2
06021R	RNG 252-4	BUJE BRONCE 1 1/2" x 1 1/4" x 3.00"	2
06021BMR	RNG	BUJE BI-METÁLICO 1 1/2" x 1 1/4" x 3.00"	2
14040F	1367-A = 2031	PERCHA F600 / B600 DERERCHA	2
14038F	1366-A=2030	PERCHA FORD F600 / B600 IZQUIERDA	8
2153	2153	SOBRE MUELLE FUNDICIÓN P/SUSPENSIÓN	8
16003	S-71	SOPORTE	2
5030	5030	PERCHA TRASERA IZQUIERDA	2
5029	5029	PERCHA TRASERA DERECHA	4
U6E150-C	U-E150--C	TORNILLO "U" 3/4" x 3 1/16" x 15.00"	4
U6E170-C	U-6E170-C	TORNILLO "U" 3/4" x 31/16" x 17.00"	4
U6E190-C	U-6E190-C	TORNILLO "U" 3/4" x 31/16" x 19.00"	4
U7E190-C	U-7E190-C	TORNILLO "U" 7/8" x 31/16" x 19.00"	2
FT351	FT-351	MUELLE 12 HOJAS	
		HOJA -01 3" X .401" x 29 5/82" x 29 5/8"	
FA347	FA-347	MUELLE AUXILIAR 4 HOJAS	2
		HOJA -01 3" x .360" x 19 1/2" x 19 1/2"	

VER CATÁLOGO DE MUELLES MAF 2011

FORD

FORD F-600/B600 MODELO 62-79 MUELLE FT351

TACÓN SEPARADOR



CÓDIGO: 6001
No. MAF: 6001

MAF

SEPARADOR DE
MUELLES
3/4" x 2 1/2" x 5 1/2"



CÓDIGO: 2358
No. MAF: 2358

MAF

AMORTIGUADOR
MERITOR



CÓDIGO: 85001A
No. MAF: 85001A

MAF

AMORTIGUADOR
MONROE = 85001-89410



CÓDIGO: 65102MR
No. MAF: 65102

MAF

PERCHA F600/B600
DERECHA



CÓDIGO: 14047F
No. MAF: 1383-A=2051

MAF

PERCHA F600/B600
IZQUIERDA



CÓDIGO: 14045F
No. MAF: 1382-A=2050

MAF

PERNO FORD



CÓDIGO: 13104
No. MAF: P-144-A

MAF

BUJE BRONCE
1 1/2" x 1 1/4" x 3.00"

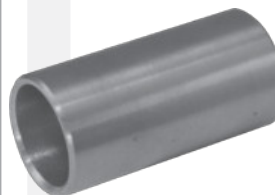

CÓDIGO: 06021R
No. MAF: RNG 252-4

MAF

PERCHA F600/B600
DERECHA



CÓDIGO: 14040F
No. MAF: 1367-A = 2031

MAF

PERCHA F600/B600
IZQUIERDA



CÓDIGO: 14038F
No. MAF: 1366-A = 2030

MAF

SOBRE MUELLE FUND.
P/SUSPENSIÓN



CÓDIGO: 2153
No. MAF: 2153

MAF

SOPORTE



CÓDIGO: 16003
No. MAF: S-71

MAF

FORD

FORD F-600/B600
 MODELO 62-79 MUELLE FT351

PERCHA TRASERA
 IZQUIERDA



CÓDIGO: 5030
 No. MAF: 5030

PERCHA TRASERA
 DERECHA



CÓDIGO: 5029
 No. MAF: 5029

TORNILLO "U"
 3/4" x 3 1/16" x 19.00



CÓDIGO: U6E190-C
 No. MAF: U-6E190-C

TORNILLO "U"
 7/8" x 3 1/16" x 19.00



CÓDIGO: U7E190-C
 No. MAF: U-7E190-C

TORNILLO "U"
 3/4" x 3 1/16" x 15.00



CÓDIGO: U6E150-C
 No. MAF: U-6E150-C

TORNILLO "U"
 3/4" x 3 1/16" x 17.00



CÓDIGO: U6E170-C
 No. MAF: U-6E170-C

BUJE BI-METÁLICO
 1 1/2" x 1 1/4" x 3.00"



CÓDIGO: 06021BMR
 No. MAF: RNG

Garantía en Calidad y Servicio

FORD

FORD F-350
MODELO 95-97 MUELLE FT492

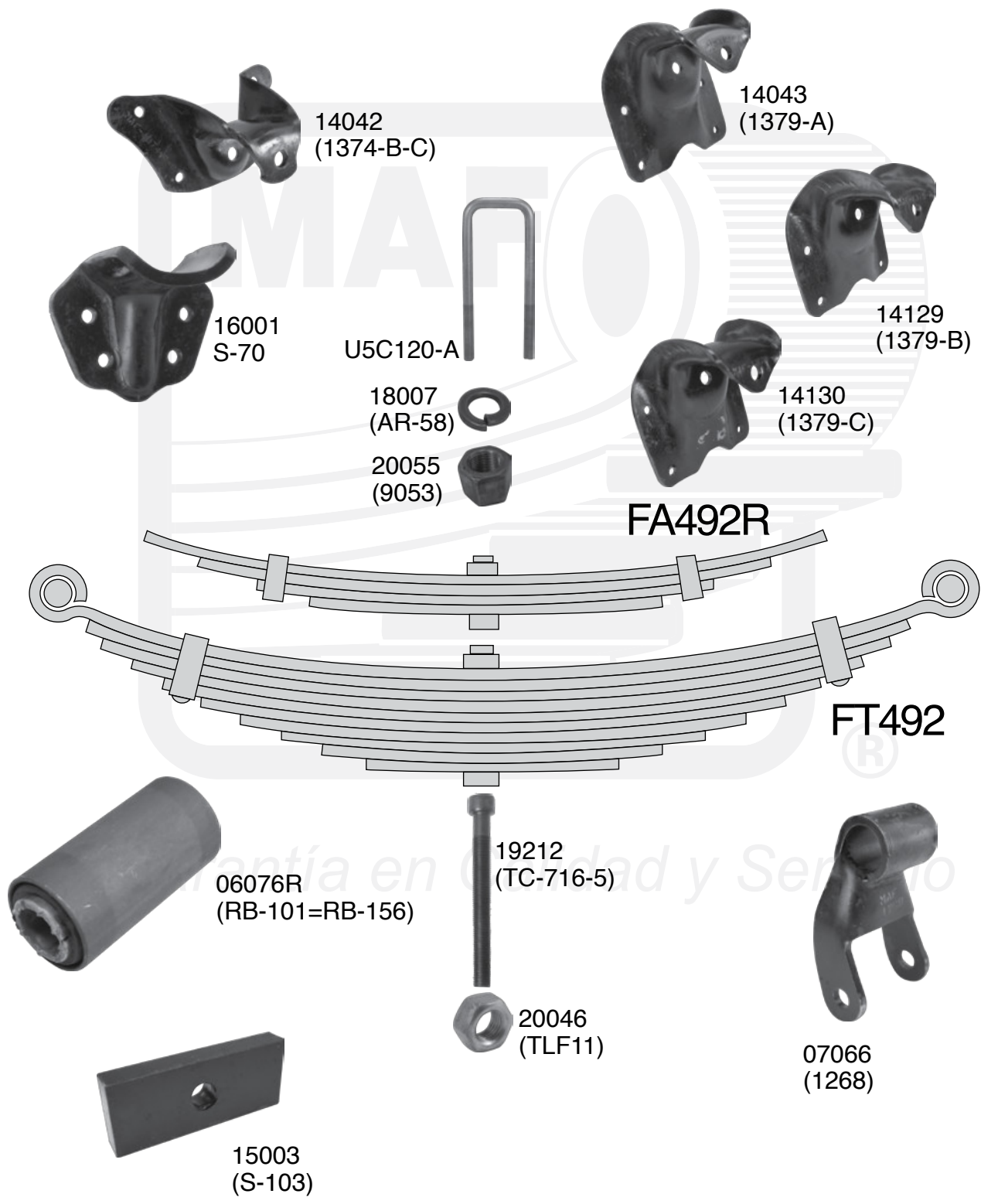

FORD

FORD F-350
 MODELO 95-97 MUELLE FT492

CÓDIGO	No. MAF	DESCRIPCIÓN	CANTIDAD
14130	1379-C	PERCHA	2
14129	1379-B	PERCHA	2
14043	1379-A	PERCHA	2
07066	1268	COLUMPIO	2
06076R	RB-101 = RB-156	BUJE FIERRO Y HULE	4
15003	S-103	SEPARADOR 2 1/4" x 5 1/2" x 7/8"	2
14042	1374-B-C	PERCHA	2
16001	S-70	SOPORTE	4
U5C120-A	U-5C120-A	TORNILLO "U" 5/8" x 2 5/16" x 12.00"	4
20055	9053	TUERCA FINA ALTA DE 5/8" °8	8
18007	AR-58	RONDANA DE PRESIÓN 5/8"	8
20046	TLF11	TUERCA UNF °2 DE 7/16"	1
19212	TC-716-5	TORNILLO DE CENTRO 7/16" x 5.00"	1
FT492	FT-492	MUELLE DE 10 HOJAS	2
		HOJA 01 2 1/4" x .401" x 26" x 26"	
FA492R	FA-492R	MUELLE AUXILIAR DE 4 HOJAS	2
		HOJA 01 2 1/4" x .323" 20 3/4" x 20 3/4"	

Garantía en Calidad y Servicio

FORD

FORD F-350 MODELO 95-97 MUELLE FT492

<p>PERCHA</p>  <p>CÓDIGO: 14130 No. MAF: 1379-C</p> <p>MAF</p>	<p>PERCHA</p>  <p>CÓDIGO: 14129 No. MAF: 1379-B</p> <p>MAF</p>	<p>PERCHA</p>  <p>CÓDIGO: 14043 No. MAF: 1379-4</p> <p>MAF</p>	<p>COLUMPIO</p>  <p>CÓDIGO: 07066 No. MAF: 1268</p> <p>MAF</p>
<p>BUJE FIERRO Y HULE</p>  <p>CÓDIGO: 06076R No. MAF: RB-01=RB-156</p> <p>MAF</p>	<p>SEPARADOR 2 1/4" x 5 1/2" x 7/8"</p>  <p>CÓDIGO: 15003 No. MAF: S-103</p> <p>MAF</p>	<p>PERCHA</p>  <p>CÓDIGO: 14042 No. MAF: 1374-B-C</p> <p>MAF</p>	<p>SOPORTE</p>  <p>CÓDIGO: 16001 No. MAF: S-70</p> <p>MAF</p>
<p>TORNILLO "U" 5/8" x 2 5/16" x 12.00</p>  <p>CÓDIGO: U5C120-A No. MAF: U-5C120-A</p> <p>MAF</p>	<p>TUERCA FINA ALTA 5/8" 08</p>  <p>CÓDIGO: 20055 No. MAF: 9053</p> <p>MAF</p>	<p>RONDANA DE PRESIÓN 5/8"</p>  <p>CÓDIGO: 18007 No. MAF: AR-58</p> <p>MAF</p>	<p>TUERCA UNF 02 DE 7/16"</p>  <p>CÓDIGO: 20046 No. MAF: TLF11</p> <p>MAF</p>

FORD

FORD F-350
MODELO 95-97 MUELLE FT492TORNILLO CENTRO
7/16" x 5.00"CÓDIGO: 19212
No. MAF: TC-716-5

MAF



Garantía de Calidad y Servicio

Muelles de Calidad

Es recomendable cuando se presente la necesidad de reemplazar una hoja de la muelle por fatiga o por fractura.

CAMBIAR LA MUELLE PARABOLICA COMPLETA.

Por seguridad es recomendable hacer la reposición de la muelle parabólica



FRUEHAUF

REMOLQUE FRUEHAUF PRO-TRAC NT2/NT2W EJE SENCILLO MUELLE Z TRA086



FRUEHAUF

REMOLQUE FRUEHAUF PRO-TRAC NT2/NT2W EJE SENCILLO MUELLE Z TRA086

CÓDIGO	No. MAF	DESCRIPCIÓN	CANTIDAD
TRK5384HD	TRK5384HD	KIT BUJE BALANCÍN	4
2268	2268	PER. BALANCÍN FRUEHAUF 2" x 10 11/16" 2 CDA 1" C/TyR	4
TRK6300	TRK6300	KIT DE BUJES TENSOR FRUEHUF	4
2350	2350	PERNO TENSOR FRUEHAUF 1 1/4" X 6"G2 ROSCA 1"14NF	4
7002	7002	TAPA INFERIOR EJE CUADRADO	2
2163	2163	SOPORTE DE EJE DE SUSPENSIÓN AIRE	2
PRN0030	PRN0030	PERNO P/ TENSOR 1 1/4" FRUEHAUF DOBLE CUERDA	2
09UXA0016	2350S/T	PERNO TENSOR FRUEHAUF 1 1/4" x 6" G2 ROSCA 1" 14NF	4
0002F	0002F	RONDANA 1 1/16" x 2 1/2" OD X 1/4 THK	4
SFH0015	SFH0015	ASIENTO DE MUELLE EJE CUADRADO FRUEHAUF	2
65421MR	65421MR	AMORTIGUADOR MONROE = 85321 MERITOR	2
PBJ1037	PBJ-1037	BUJE CÓNICO PARA TIRANTE FRUEHAUF	8
2001T	2001	BUJE AHULADO PARA TENSOR DE REMOLQUE	8
2001H	2001H	BUJE CÓNICO P/TENSOR FRUEHAUF #0074 RPH	8
2001-1T	2001-1	BUJE CÓNICO P/TENSOR FRUEHAUF C/BUJE INT.	8
TR006	TR006	TENSOR AJUSTABLE FRUEHAUF 15 7/8"	1
TR003	TR003	TENSOR FRUEHAUF 12 3/8"	1
TNS0004	TNS0004	TENSOR P/SUSP. FRUEHAUF FIJO CORTO PHM 2194	1
TNS0002	TNS0002	TENSOR AJUSTABLE C. PHM 2191	1
TNS0001	TNS0001	TENSOR P/SUSPENSIÓN AJUSTABLE L. PHM 2	1
98276	TR003	TENSOR AJUSTABLE 12 3/8"	1
2193	2193	TENSOR FIJO P/ HULE CÓNICO TIPO 17"	1
2187	2187	TENSOR FIJO P/HULE CÓNICO TIPO 19"	1
2103	2103	TENSOR CÓNICO TIPO FIJO DE 13 1/2"	1
1R12281	1R12281	BOLSA DE AIRE GOODYEAR	2
2153	2153	SOBRE MUELLE FUNDICIÓN P/SUSPENSIÓN	2
PBJ1037	PBJ-1037	BUJE CÓNICO P/BALANCÍN FRUEHAUF	8
2002T	2002	BUJE CÓNICO P/BALANCÍN FRUEHAUF	8
2002H	2002H	BUJE CÓNICO P/BALANCÍN FRUEHAUF BUJE	8

FRUEHAUF

REMOLQUE FRUEHAUF PRO-TRAC NT2/NT2W EJE SENCILLO MUELLE Z TRA086

CÓDIGO	No. MAF	DESCRIPCIÓN	CANTIDAD
2002-1T	2002-1	CÓNICO P/TENSOR C/BUJE INTERNO	8
0003F	0003F	RONDANA 1 1/16" x 4.00" x 1/4"	4
U7E150-C	U-7E150-C	TORNILLO "U" 7/8" x 3 1/16" x 15.00"	4
20057	9055	TUERCA FINA DE 3/8" 08	8
18009	AR78	RONDANA DE PRESIÓN 7/8"	8
171H0045CE	171H0045CE	VÁLVULA NIVELADORA HADLEY UNIVERSAL	1
60215000R	60215-000	B/TORSIÓN TRANSV. CÓNICA ULTRA ROD. AJUS.	2
TRA086	TRA086=UVA00092-1	HOJA TIPO Z 3" x 13/4" x 211/8" x 193/4"	2

VER CATÁLOGO DE MUELLES 2011



Criterios de Falla Bolsas de aire

Sobretorque

Causa de Falla

Los montajes se pueden romper o las roscas se pueden dañar debido a sobretorque. (Nota: Aceites o lubricantes en las roscas puede afectar el torque y puede causar daños)

Las bolsas de aire se pueden torcer lo cual reduce la vida útil de la membrana de manera considerable.

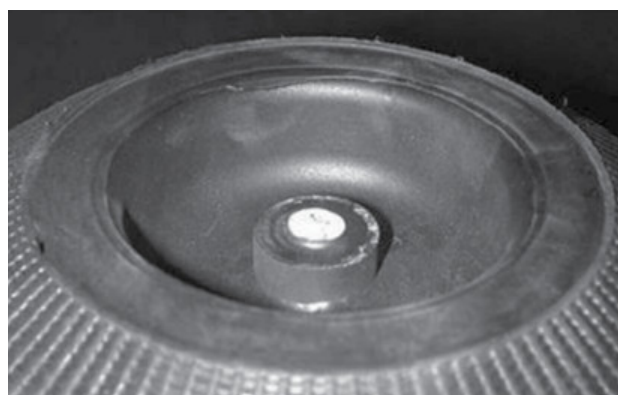

FRUEHAUF

REMOLQUE FRUEHAUF PRO-TRAC NT2/NT2W EJE SENCILLO MUELLE Z TRA086

BUJE DE BALANCÍN



CÓDIGO: TRK5384HD
No. MAF: TRK5384HD
MAF

PERNO BALANCÍN
2" x 10 11/16" ²2 CDA 1"
C/TyR



CÓDIGO: 2268
No. MAF: 2268
MAF

KIT DE BUJES TENSOR



CÓDIGO: TRK6300
No. MAF: TRK6300
MAF

PERNO TENSÓR
1 1/4" x 6" G2 ROSCA 1
1" 14NF



CÓDIGO: 2350
No. MAF: 2350
MAF

TAPA INFERIOR EJE CUADRADO



CÓDIGO: 7002
No. MAF: 7002
MAF

SOPORTE DE EJE DE SUSPENSIÓN DE AIRE



CÓDIGO: 2163
No. MAF: 2163
MAF

PERNO P/TENSÓR 1 1/4" DOBLE CUERDA



CÓDIGO: PRN0030
No. MAF: PRN0030
MAF

PERNO TENSÓR
1 1/4" x 6" G2 ROSCA 1"
14NF



CÓDIGO: 09UXA0016
No. MAF: 2350S/T
MAF

RONDANA 1 1/16" x
2 1/2" OD 1/4 THK



CÓDIGO: 0002R
No. MAF: 0002R
MAF

ASIENTO DE MUELLE EJE CUADRADO



CÓDIGO: SFH0015
No. MAF: SFH0015
MAF

AMORTIGUADOR
MONROE = 85321
MERITOR



CÓDIGO: 65421MR
No. MAF: 65421MR
MAF

BUJE CÓNICO PARA TIRANTE



CÓDIGO: PBJ1037
No. MAF: PBJ-1037
MAF

FRUEHAUF

REMOLQUE FRUEHAUF PRO-TRAC NT2/NT2W EJE SENCILLO MUELLE Z TRA086

BUJE HULE TENSOR
DE REMOLQUE



CÓDIGO: 2001T
No. MAF: 2001

MAF

BUJE CÓNICO TENSOR
FRUEHAUF #0074 RPH



CÓDIGO: 2001H
No. MAF: 2001H

MAF

BUJE CÓNICO TENSOR
FRUEHAUF C/BUJE INT.



CÓDIGO: 2001-1T
No. MAF: 2001-1

MAF

TENSOR AJUSTABLE
15 7/8"



CÓDIGO: TRN006
No. MAF: TR006

MAF

TENSOR FRUEHAUF
12 3/8"



CÓDIGO: TR003
No. MAF: TR003

MAF

TENSOR P/SUSP. FIJO
CORTO PHM 2194



CÓDIGO: TNS0004
No. MAF: TNS0004

MAF

TENSOR AJUSTABLE C.
PHM 2191



CÓDIGO: TNS0002
No. MAF: TNS0002

MAF

TENSOR P/SUSP.
AJUST. L. PHM 2



CÓDIGO: TNS0001
No. MAF: TNS0001

MAF

TENSOR AJUSTABLE
12 3/8"



CÓDIGO: 98276
No. MAF: TR003

MAF

TENSOR FIJO P/HULE
CÓNICO TIPO 17"



CÓDIGO: 2193
No. MAF: 2193

MAF

TENSOR FIJO P/HULE
CÓNICO TIPO 19"



CÓDIGO: 2187
No. MAF: 2187

MAF

TENSOR CÓNICO TIPO
FIJO DE 13 1/2"



CÓDIGO: 2103
No. MAF: 2103

MAF

FRUEHAUF

REMOLQUE FRUEHAUF PRO-TRAC NT2/NT2W EJE SENCILLO MUELLE Z TRA086

BOLSA DE AIRE
GOODYEAR



CÓDIGO: 1R12281
No. MAF: 1R12281

MAF

SOBRE MUELLE
FUNDICIÓN P/SUSP.



CÓDIGO: 2153
No. MAF: 2153

MAF

BUJE CÓNICO PARA
BALANCÍN



CÓDIGO: PBJ1038
No. MAF: PBJ-1038

MAF

BUJE CÓNICO PARA
BALANCÍN



CÓDIGO: 2002T
No. MAF: 2002

MAF

BUJE CÓNICO P/
TENSOR C/BUJE INT.



CÓDIGO: 2002-1T
No. MAF: 2002-1T

MAF

RONDANA 1 1/16" x
4.00" OD x 1/4" MAF



CÓDIGO: 0003R
No. MAF: 0003R

MAF

TORNILLO "U"
7/8" x 3 1/16" x 15.00"



CÓDIGO: U7E150-C
No. MAF: U-7E150-C

MAF

TUERCA FINA ALTA
7/8" Ø8



CÓDIGO: 20057
No. MAF: 9055

MAF

RONDANA DE
PRESIÓN 7/8"



CÓDIGO: 18009
No. MAF: AR-78

MAF

VALVULA NIVELADORA
HADLEY UNIVERSAL

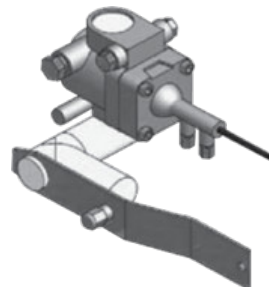

CÓDIGO: 171H0045CE
No. MAF: 171H0045CE

MAF

B/TORSIÓN TRANSV.
CÓNICA ULTRA ROD.
AJUS.



CÓDIGO: 60215000R
No. MAF: 60215-000

MAF

BUJE CÓNICO PARA
BALANCÍN



CÓDIGO: 2002H
No. MAF: 2002H

MAF

INSTRUCCIONES PARA MEDIR MUELLES

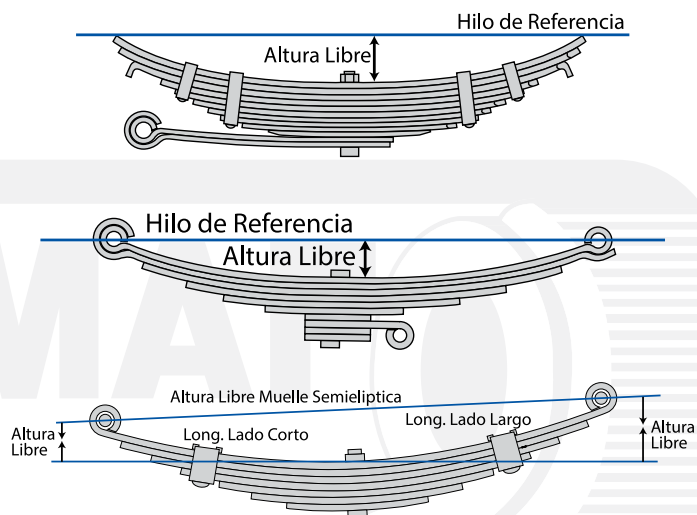

1. La altura libre (arco libre) se mide tomando un hilo de referencia ya sea al centro de los roles o al ras de las hojas por el lado del patín.

(hay excepciones donde se debe tomar la medida a puntos de apoyo, también existe la posibilidad de tomar dos alturas cuando la muelle sea semielíptica).

Se debe tensar el hilo y con una cinta métrica se toma la medida tocando la punta de la cinta del metro a la hoja maestra en dirección hacia donde está el tornillo del centro.

Se toma la medida que coincida con el hilo.

2. Las longitudes de los lados corto y largo se miden sobre el contorno de la hoja a medir, tomando en cuenta desde el extremo hacia perforación central, considerando que éstas fueron tomadas cuando la hoja de la muelle estaba plana.

Cuando la hoja maestra (principal) tiene los roles, las longitudes, se toman del centro del diámetro de rol a la perforación central.

NOTA: seguir con un flexómetro el contorno de la hoja

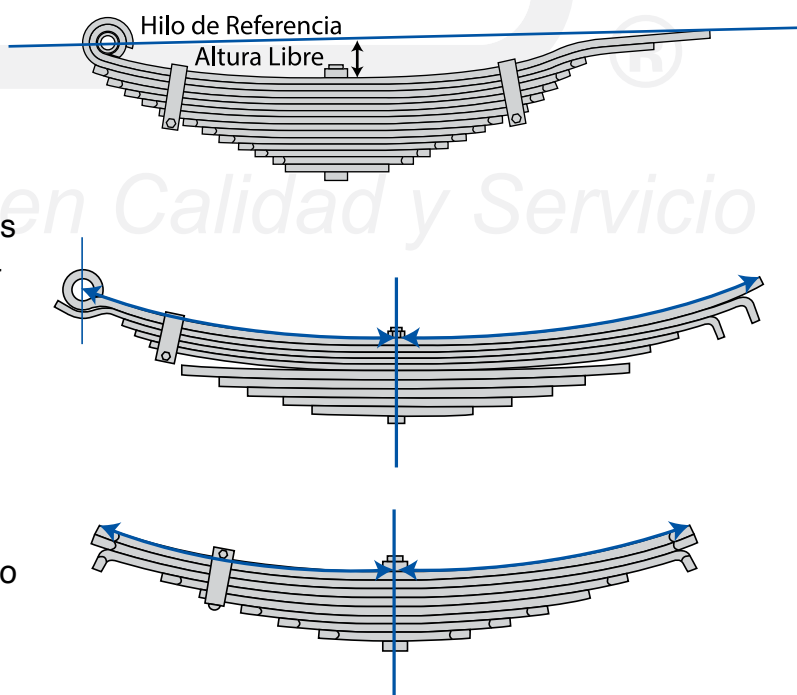

FRUEHAUF

FRUEHAUF
CAJAS Y REMOLQUES 4 MUELLE
FRT201



FRUEHAUF

FRUEHAUF
CAJAS Y REMOLQUES 4 MUELLE
FRT201

CÓDIGO	No. MAF	DESCRIPCIÓN	CANTIDAD
TRK6300	TRK6300	KIT DE BUJES PARA TENSOR	2
2350	2350	TENSOR FRUEHAUF 1 1/4" x 6" G2 ROSCA 1" 14NF	2
TRK5384HD	TRK5384HD	BUJE BALANCÍN FRUEHAUF	2
2268BCP	2268BCP	KIT PERNO BALANCÍN C/RONDANA, TUERCA Y BUJES	2
2268BCH	2268BCH	KIT PERNO BALANCÍN C/RONDANA, TUERCA Y BUJES	2
2268	2268	PER BALANCÍN FRUEHAUF 2"x 10" 11/16" °2 CDA 1" C/TyR	2
TR006	TR006	TENSOR AJUSTABLE FRUEHAUF 15 7/8"	2
TR003	TR003	TENSOR FRUEHAUF 12 3/8"	2
TNS0004	TNS0004	TENSOR P/SUSP.FRUEHAUF FIJO CORTO PHM 2194	2
TNS0002	TNS0002	TENSOR P/ SUSP.FRUEHAUF AJUST. C. PHM 2191	2
TNS0001	TNS0001	TENSOR P/SUSP. FRUEHAUF AJUST. L. PHM 2	2
98276	TR003	TENSOR AJUSTABLE FRUEHAUF 12 3/8"	2
2193	2193	TENSOR FIJO P/ HULE CÓNICO TIPO FRUEHAUF 17"	2
2187	2187	TENSOR FIJO P/HULE CÓNICO TIPO FRUEHAUF 19"	2
2103	2103	TENSOR CÓNICO TIPO FRUEHAUF FIJO DE 13 1/2"	2
SFH0001	SFH0001	SOPORTE EJE REDONDO P/FRUEHAUF PHM 2162	2
SFH0002	SFH0002	SOPORTE EJE CUADRADO (MÉNSULA) PHM 2161	2
0002F	0002F	RONDANA 1 1/16" 2 1/2" OD X 1/4" THK	2
SFH0003	SFH0003	RONDANA P/PERNO DE TENSOR FRUEHAUF	2
2154	2154	ASIENTO EJE REDONDO 5"SUSP. 2 7/8" X 5 3/4"	2
SFH0015	SFH0015	ASIENTO DE MUELLE EJE CUADRADO FRUEHAUF	2
PBJ1037	PBJ-1037	BUJE CÓNICO PARA TIRANTE FRUEHAUF	2
2001T	2001	BUJE AHULADO PARA TENSOR DE REMOLQUE	2
2001H	2001H	BUJE CÓNICO P/TENSOR FRUEHAUF #0074 RPH	2
2001-1T	2001-1T	BUJE CÓNICO P/TENSOR FRUEHAUF C/BUJE INT.	2
PRN0029	PRN0029	PERNO P/BALANCÍN FRUEH, S/TCA. Y RONDANA	2
PRN0030	PRN0030	PERNO P/ TENSOR 1 1/4" FRUEHAUF DOBLE CUERDA	2
09UXA0016	2350S/T	PERNO TENSOR FRUEHAUF 1 1/4" x 6" G2 ROSCA 1" 14NF	4
U7E190-C	U-7E190-C	TORNILLO "U" 7/8" x 3 1/16" x 19.00"	

FRUEHAUF

FRUEHAUF CAJAS Y REMOLQUES 4 MUELLE FRT201

CÓDIGO	No. MAF	DESCRIPCIÓN	CANTIDAD
U7E150-C	U-7E150-C	TORNILLO "U" 7/8" x 3 1/16" x 15.00"	4
U7E130-C	U-7E130-C	TORNILLO "U" 7/8" x 3 1/16" x 13.00"	4
EQ015	EQ015	BALANCÍN FRUEHAUF	2
BLN0021-1	BLN0021-1	BALANCÍN FRUEHAUF (PLACA) RECTO P/BUJE DE 2"	2
BLN0021	BLN0021	BALANCÍN P/ SUSP. FRUEHAUF CONICO (PLACA)	2
BLN0001	BLN0001	BALANCÍN P/SUSP. FRUEHAUF 9 H	2
2180	2180	BALANCÍN FRUEHAUF P/SUSP 9 HOJAS = EQ015	2
2153	2153	SOBRE MUELLE FUNDICIÓN P/SUSP. FRUEHAUF	2
PBJ1038	PBJ-1038	BUJE CÓNICO P/BALANCÍN FRUEHAUF = 2002H	2
2002T	2002	BUJE CÓNICO PARA BALANCÍN FRUEHAUF	2
2002H	2002H	BUJE CÓNICO P/BALANCÍN FRUEHAUF #0075 RPH	2
2002-1T	2002-1	BUJE CÓNICO P/BALANCÍN FRUEHAUF C/BUJE INT	2
SFH0010R	SFH0010-R	PERCHA TRASERA FRUEHAUF REFORZADA	2
SFH0010	SFH0010	PERCHA TRASERA FRUEHAUF	2
SFH0008R	SFH0008-R	PERCHA DELANTERA FRUEHAUF REFORZADA	2
SFH0008	SFH0008	PERCHA DELANTERA FRUEHAUF	2
SFH0009R	SFH0009-R	PERCHA CENTRAL FRUEHAUF REFORZADA	2
SFH0009	SFH0009	PERCHA CENTRAL FRUEHAUF	2
SFH0007	SFH0007	RONDANA P/PERNO DE BALANCÍN FRUEHAUF	2
0003F	0003F	RONDANA 1 1/16" x 4.00" OD x 1/4 MAF	2
FRT201	FRT201	MUELLE DE 4 HOJAS	2
HOJA 01 3" x .788" x 21 1/2" x 21 1/2"			

VER CATÁLOGO DE MUELLES MAF 2011

FRUEHAUF

FRUEHAUF
CAJAS Y REMOLQUES 4 MUELLE
FRT201KIT DE BUJES
TENSORCÓDIGO: TRK6300
No. MAF: TRK6300

MAF

BUJE BALANCÍN

CÓDIGO: TRK5384HD
No. MAF: TRK5384HD

MAF

KIT PERNO BALANCÍN
C/RONDANA, TUERCA,
BUJESCÓDIGO: 2268BCP
No. MAF: 2268BCP

MAF

KIT PERNO BALANCÍN
C/RONDANA, TUERCA,
BUJESCÓDIGO: 2268BCH
No. MAF: 2268BCH

MAF

PNO. TENSOR 1 1/4 X 6
G2 ROSC. 1" 14H NFCÓDIGO: 2350
No. MAF: 2350

MAF

TENSOR AJUSTABLE
15 7/8"CÓDIGO: TR006
No. MAF: TR006

MAF

TENSOR FRUEHAUF
12 3/8"CÓDIGO: TR003
No. MAF: TR003

MAF

TENSOR P/SUSP. FIJO
CORTO PHM2194CÓDIGO: TNS0004
No. MAF: TNS0004

MAF

PER. BALANCÍN
2" x 10 11/16" Ø2 CDA 1"
C/TyRCÓDIGO: 2268
No. MAF: 2268

MAF

TENSOR P/SUSP.
AJUST. C. PHM 2191CÓDIGO: TNS0002
No. MAF: TNS0002

MAF

TENSOR P/SUSP.
AJUST. L. PHM 2CÓDIGO: TNS0001
No. MAF: TNS0001

MAF

TENSOR AJUSTABLE
12 3/8"CÓDIGO: 98276
No. MAF: TR003

MAF

FRUEHAUF

FRUEHAUF
CAJAS Y REMOLQUES 4 MUELLE
FRT201

TENSOR FIJO PARA
HULE CÓNICO TIPO
FRUEHAUF 17"



CÓDIGO: 2193
No. MAF: 2193

MAF

TENSOR FIJO PARA
HULE CÓNICO TIPO
FRUEHAUF 19"



CÓDIGO: 2187
No. MAF: 2187

MAF

TENSOR CÓNICO TIPO
FRUEHAUF FIJO 13 1/2"



CÓDIGO: 2103
No. MAF: 2103

MAF

SOPORTE EJE
REDONDO PHM 2162



CÓDIGO: SFH0001
No. MAF: SFH0001

MAF

SOPORTE EJE
CUADRADO (MENSULA)
PHM 2161



CÓDIGO: SFH0002
No. MAF: SFH0002

MAF

RONDANA 1 1/16" x
2 1/2" OD X 1/4" THK



CÓDIGO: 0002F
No. MAF: 0002F

MAF

RONDANA P/PERNO
TENSOR



CÓDIGO: SFH0003
No. MAF: SFH0003

MAF

ASIENTO EJE
REDONDO 5" SUSP.
2 7/8" x 5 3/4"



CÓDIGO: 2154
No. MAF: 2154

MAF

ASIENTO DE MUELLE
EJE CUADRADO



CÓDIGO: SFH0015
No. MAF: SFH0015

MAF

BUJE CÓNICO PARA
TIRANTE



CÓDIGO: PBJ1037
No. MAF: PBJ1037

MAF

BUJE AHULADO PARA
TENSOR DE RESORTE



CÓDIGO: 2001T
No. MAF: 2001

MAF

BUJE CÓNICO
P/TENSOR FREHAUF
#0074 RPH



CÓDIGO: 2001H
No. MAF: 2001H

MAF

FRUEHAUF

FRUEHAUF
CAJAS Y REMOLQUES 4 MUELLE
FRT201

BUJE CÓNICO
P/TENSOR FREHAUF
C/BUJE INT



CÓDIGO: 2001-1T
No. MAF: 2001-1T

MAF

PERNO P/TENSOR
1 1/4" DOBLE CUERDA



CÓDIGO: PRN0030
No. MAF: PRN0030

MAF

PERNO TENSOR
1 1/4" x 6" D2 ROSCA 1"
14 NF



CÓDIGO:
09UXA0016PRN0030
No. MAF: 2350S/T

MAF

TORNILLO "U"
7/8" x 3 1/16" x 19.00"



CÓDIGO: U7E190-C
No. MAF: U-7E190-C

MAF

TORNILLO "U"
7/8" x 3 1/16" x 15.00"



CÓDIGO: U7E150-C
No. MAF: U-7E150-C

MAF

TORNILLO "U"
7/8" x 3 1/16" x 13.00"



CÓDIGO: U7E130-C
No. MAF: U-7E130-C

MAF

BALANCÍN FRUEHAUF



CÓDIGO: EQ015
No. MAF: EQ015

MAF

BALANCÍN FRUEHAUF
(PLACA) RECTO
P/BUJE DE 2"



CÓDIGO: BLN0021-1
No. MAF: BLN0021-1

MAF

BALANCÍN P/ SUSP.
FRUEHAUF
CÓNICO(PLACA)



CÓDIGO: BLN0021
No. MAF: BLN0021

MAF

BALANCÍN P/ SUSP.
FRUEHAUF 9H



CÓDIGO: BLN0001
No. MAF: BLN0001

MAF

BALANCÍN P/ SUSP.
FRUEHAUF
9H = EQ015



CÓDIGO: 2180
No. MAF: 2180

MAF

PERNO P/BALANCÍN
FRUEHAUF S/TUERCA
Y RONDANA









CÓDIGO: PRN0029
No. MAF: PRN0029

MAF

FRUEHAUF

FRUEHAUF
CAJAS Y REMOLQUES 4 MUELLE
FRT201

<p>SOBRE MUELLE FUND. P/SUSP.</p>  <p>CÓDIGO: 2153 No. MAF: 2153</p>	<p>BUJE CÓNICO P/BALANCÍN 2002H</p>  <p>CÓDIGO: PBJ1038 No. MAF: PBJ1038</p>	<p>BUJE CÓNICO P/BALANCÍN</p>  <p>CÓDIGO: 2002T No. MAF: 2002</p>	<p>BUJE CÓNICO P/BALANCÍN #0075 RPH</p>  <p>CÓDIGO: 2002H No. MAF: 2002H</p>
<p>BUJE CÓNICO P/BALANCÍN C/BUJE INT.</p>  <p>CÓDIGO: 2002-1T No. MAF: 2002-1T</p>	<p>PERCHA TRAS. REFORZADA</p>  <p>CÓDIGO: SFH0010R No. MAF: SFH0010-R</p>	<p>PERCHA TRASERA</p>  <p>CÓDIGO: SFH0010 No. MAF: SFH0010</p>	<p>PERCHA DELANTERA REFORZADA</p>  <p>CÓDIGO: SFH0008R No. MAF: SFH0008-R</p>
<p>PERCHA DELANTERA</p>  <p>CÓDIGO: SFH0008 No. MAF: SFH0008</p>	<p>PERCHA CENTRAL REFORZADA</p>  <p>CÓDIGO: SFH0009R No. MAF: SFH0009-R</p>	<p>PERCHA CENTRAL</p>  <p>CÓDIGO: SFH0009 No. MAF: SFH0009</p>	<p>RONDANA P/PERNO DE BALANCÍN</p>  <p>CÓDIGO: SFH0007 No. MAF: SFH0007</p>

FRUEHAUF

FRUEHAUF
CAJAS Y REMOLQUES 4 MUELLE
FRT201

Criterios de Falla Bolsas de aire

Sobre extensión

La bolsa de aire está operando fuera de la máxima altura recomendada como resultado de una carrera no restringida o excesiva del brazo de la suspensión (sistema de nivel defectuoso/ impropio, o bolsa de aire incorrecta).

El abuso de la carrera puede resultar en la separación de la membrana de las partes de montaje.

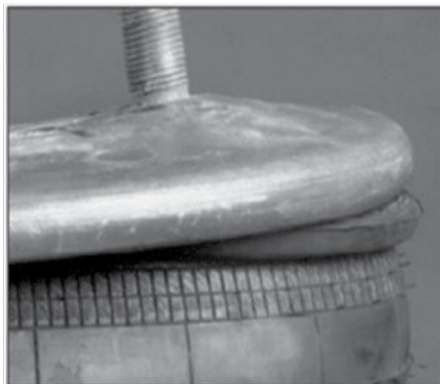

FRUEHAUF

FRUEHAUF
CAJAS Y REMOLQUES
4 MUELLE FRT552

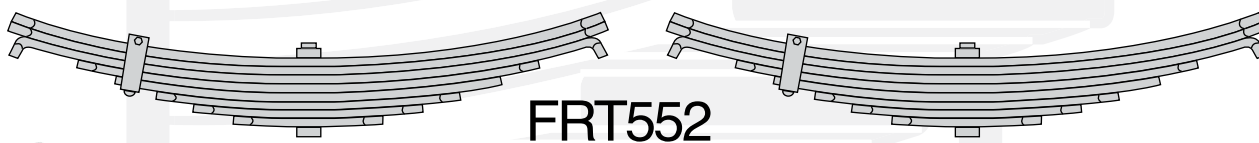
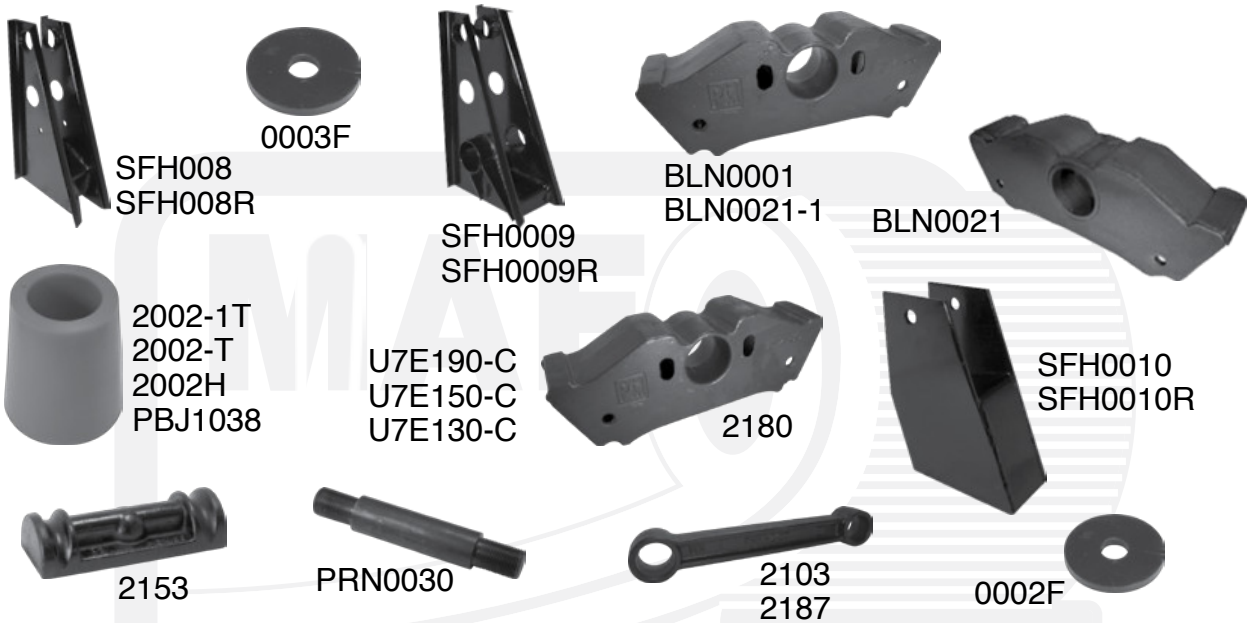

FRUEHAUF

FRUEHAUF
CAJAS Y REMOLQUES
4 MUELLE FRT552

CÓDIGO	No. MAF	DESCRIPCIÓN	CANTIDAD
TRK6300	TRK6300	KIT DE BUJES TENSOR	2
2350	2350	PERNO TENSOR FRUEHAUF 1 1/4" x 6" G2 ROSCA 1"14NF	2
TRK5384HD	TRK5384HD	BUJE BALANCÍN FRUEHAUF	2
2268BCP	2268BCP	KIT PERNO BALANCÍN C/RONDANA,TUERCA, BUJES	2
2268BCH	2268BCH	KIT PERNO BALANCÍN C/RONDANA,TUERCA, BUJES	2
2268	2268	PER. BALANCÍN FRUEHAUF 2" x 10 11/16" °2 CDA 1" C/TyR	2
TR006	TR006	TENSOR AJUSTABLE FRUEHAUF 15 7/8"	2
TR003	TR003	TENSOR FRUEHAUF 12 3/8"	2
TNS0004	TNS0004	TENSOR P/SUSP. FRUEHAUF FIJO CORTO PHM 2194	2
TNS0002	TNS0002	TENSOR P/ SUSP. FRUEHAUF AJUST. C. PHM 2191	2
TNS0001	TNS0001	TENSOR P/SUSP. FRUEHAUF AJUST. L. PHM 2	2
98276	TR003	TENSOR AJUSTABLE FRUEHAUF 12 3/8"	2
2193	2193	TENSOR FIJO P/ HULE CÓNICO TIPO FRUEHAUF 17"	2
2187	2187	TENSOR FIJO P/HULE CÓNICO TIPO FRUEHAUF 19"	2
2103	2103	TENSOR CÓNICO TIPO FRUEHUF FIJO DE 13 1/2	2
SFH0001	SFH0001	SOPORTE EJE REDONDO P/FRUEHAUF PHM 2162	2
SFH0002	SFH0002	SOPORTE EJE CUADRADO (MÉNSULA) PHM 2161	2
0002F	0002F	RONDANA 1 1/16" 2 1/2" OD x 1/4" THK	2
SFH0003	SFH0003	RONDANA P/PERNO DE TENSOR FRUEHAUF	2
2154	2154	ASIENTO EJE REDONDO 5" SUSP. 2 7/8" x 5 3/4"	2
SFH0015	SFH0015	ASIENTO DE MUELLE EJE CUADRADO FRUEHAUF	2
PBJ1037	PBJ-1037	BUJE CÓNICO PARA TIRANTE FRUEHAUF	2
2001T	2001	BUJE AHULADO PARA TENSOR DE REMOLQUE	2
2001H	2001H	BUJE CÓNICO P/TENSOR FRUEHAUF #0074 RPH	2
2001-1T	2001-1T	BUJE CÓNICO P/TENSOR FRUEHAUF C/BUJE INT	2
PRN0030	PRN0030	PERNO P/ TENSOR 1 1/4" FRUEHAUF DOBLE CUERDA	2
09UXA0016	2350S/T	PERNO TENSOR FRUEHAUF 1 1/4" x 6" G2 ROSCA 1" 14NF	2
U7E190-C	U-7E190-C	TORNILLO "U" 7/8" x 3 1/16" x 19.00"	4
U7E150-C	U-7E150-C	TORNILLO "U" 7/8" x 3 1/16" x 15.00"	4

FRUEHAUF

FRUEHAUF
CAJAS Y REMOLQUES
4 MUELLE FRT552

CÓDIGO	No. MAF	DESCRIPCIÓN	CANTIDAD
U7E130-C	U-7E130-C	TORNILLO "U" 7/8" x 3 1/16" x 13.00"	4
BLN0021-1	BLN0021-1	BALANCÍN FRUEHAUF (PLACA) RECTO P/BUJE DE 2"	2
BLN0021	BLN0021	BALANCÍN P/ SUSP. FRUEHAUF CÓNICO(PLACA)	2
BLN0001	BLN0001	BALANCÍN P/SUSP. FRUEHAUF 9 H	2
2180	2180	BALANCÍN FRUEHAUF P/SUSP 9 HOJAS = EQ015	2
2153	2153	SOBRE MUELLE FUNDICIÓN P/SUSP. FRUEHAUF	2
PBJ1038	PBJ-1038	BUJE CÓNICO PARA BALANCÍN FRUEHAUF = 2002H	2
2002T	2002	BUJE CÓNICO PARA BALANCÍN FRUEHAUF	2
2002H	2002H	BUJE CÓNICO PARA BALANCÍN FRUEHAUF #0075 RPH	2
2002-1T	2002-1	BUJE CÓNICO PARA BALANCÍN FRUEHAUF C/BUJE INT	2
SFH0010R	SFH0010-R	PERCHA TRASERA FRUEHAUF REFORZADA	2
SFH0010	SFH0010	PERCHA TRASERA FRUEHAUF	2
SFH0008R	SFH0008-R	PERCHA DELANTERA FRUEHAUF REFORZADA	2
SFH0008	SFH0008	PERCHA DELANTERA FRUEHAUF	2
SFH0009R	SFH0009-R	PERCHA CENTRAL FUEHAUF REFORZADA	2
SFH0009	SFH0009	PERCHA CENTRAL FRUEHAUF	2
SFH0007	SFH0007	RONDANA P/PERNO DE BALANCÍN FRUEHAUF	2
0003F	0003F	RONDANA 1 1/16" x 4.00" OD x 1/4" MAF	2
FRT552	FRT-552	MUELLE DE 8 HOJAS	4
		HOJA 01 3" x .499" x 20 3/4" x 20 3/4"	

VER CATÁLOGO DE MUELLES MAF 2011

FRUEHAUF

FRUEHAUF
CAJAS Y REMOLQUES
4 MUELLE FRT552KIT DE BUJES
TENSORCÓDIGO: TRK6300
No. MAF: TRK6300

MAF

PNO. TENSOR 1 1/4" x 6"
G2 ROSC. 1" 14H NFCÓDIGO: 2350
No. MAF: 2350

MAF

BUJE BALANCÍN

CÓDIGO: TRK5384HD
No. MAF: TRK5384HD

MAF

KIT PERNO BALANCÍN
C/RONDANA, TUERCA,
BUJESCÓDIGO: 2268BCP
No. MAF: 2268BCP

MAF

KIT PERNO BALANCÍN
C/RONDANA, TUERCA,
BUJESCÓDIGO: 2268BCH
No. MAF: 2268BCH

MAF

PER. BALANCÍN
2" x 10 11/16" °2 CDA 1"
C/TyRCÓDIGO: 2268
No. MAF: 2268

MAF

TENSOR AJUSTABLE
15 7/8"CÓDIGO: TR006
No. MAF: TR006

MAF

TENSOR FRUEHAUF
12 3/8"CÓDIGO: TR003
No. MAF: TR003

MAF

TENSOR P/SUSP. FIJO
CORTO PHM2194CÓDIGO: TNS0004
No. MAF: TNS0004

MAF

TENSOR P/SUSP.
AJUST. C. PHM 2191CÓDIGO: TNS0002
No. MAF: TNS0002

MAF

TENSOR P/SUSP.
AJUST. L. PHM 2CÓDIGO: TNS0001
No. MAF: TNS0001

MAF

TENSOR AJUSTABLE
12 3/8"CÓDIGO: 98276
No. MAF: TR003

MAF

FRUEHAUF

FRUEHAUF
CAJAS Y REMOLQUES
4 MUELLE FRT552

TENSOR FIJO PARA
HULE CÓNICO TIPO
FRUEHAUF 17"



CÓDIGO: 2193
No. MAF: 2193

MAF

TENSOR FIJO PARA
HULE CÓNICO TIPO
FRUEHAUF 19"



CÓDIGO: 2187
No. MAF: 2187

MAF

TENSOR CÓNICO TIPO
FRUEHAUF FIJO 13 1/2"



CÓDIGO: 2103
No. MAF: 2103

MAF

SOPORTE EJE
REDONDO PHM 2162



CÓDIGO: SFH0001
No. MAF: SFH0001

MAF

SOPORTE EJE
CUADRADO (MENSULA)
PHM 2161



CÓDIGO: SFH0002
No. MAF: SFH0002

MAF

RONDANA 1 1/16" x
2 1/2" OD X 1/4" THK



CÓDIGO: 0002F
No. MAF: 0002F

MAF

RONDANA P/PERNO
TENSOR



CÓDIGO: SFH0003
No. MAF: SFH0003

MAF

ASIENTO EJE
REDONDO 5" SUSP.
2 7/8" x 5 3/4"



CÓDIGO: 2154
No. MAF: 2154

MAF

ASIENTO DE MUELLE
EJE CUADRADO



CÓDIGO: SFH0015
No. MAF: SFH0015

MAF

BUJE CÓNICO PARA
TIRANTE



CÓDIGO: PBJ1037
No. MAF: PBJ-1037

MAF

BUJE AHULADO PARA
TENSOR DE RESORTE



CÓDIGO: 2001T
No. MAF: 2001

MAF

BUJE CÓNICO
P/TENSOR FREHAUF
#0074 RPH



CÓDIGO: 2001H
No. MAF: 2001H

MAF

FRUEHAUF

FRUEHAUF
CAJAS Y REMOLQUES
4 MUELLE FRT552

BUJE CÓNICO
P/TENSOR FREHAUF
C/BUJE INT



CÓDIGO: 2001-1T
No. MAF: 2001-1T

MAF

PERNO P/TENSOR
1 1/4" DOBLE CUERDA



CÓDIGO: PRN0030
No. MAF: PRN0030

MAF

PERNO TENSOR
1 1/4" x 6" D2 ROSCA 1"
14 NF



CÓDIGO:
09UXA0016PRN0030
No. MAF: 2350S/T

MAF

TORNILLO "U"
7/8" x 3 1/16" x 19.00"



CÓDIGO: U7E190-C
No. MAF: U-7E190-C

MAF

TORNILLO "U"
7/8" x 3 1/16" x 15.00"



CÓDIGO: U7E150-C
No. MAF: U-7E150-C

MAF

TORNILLO "U"
7/8" x 3 1/16" x 13.00"



CÓDIGO: U7E130-C
No. MAF: U-7E130-C

MAF

BALANCÍN P/ SUSP.
FRUEHAUF
9H = EQ015



CÓDIGO: 2180
No. MAF: 2180

MAF

BALANCÍN FRUEHAUF
(PLACA) RECTO
P/BUJE DE 2"



CÓDIGO: BLN0021-1
No. MAF: BLN0021-1

MAF

BALANCÍN P/ SUSP.
FRUEHAUF
CÓNICO(PLACA)



CÓDIGO: BLN0021
No. MAF: BLN0021

MAF

BALANCÍN P/ SUSP.
FRUEHAUF 9H



CÓDIGO: BLN0001
No. MAF: BLN0001

MAF

BUJE CÓNICO
P/BALANCÍN 2002H



CÓDIGO: PBJ1038
No. MAF: PBJ1038

MAF

BUJE CÓNICO
P/BALANCÍN



CÓDIGO: 2002T
No. MAF: 2002

MAF

FRUEHAUF

FRUEHAUF
CAJAS Y REMOLQUES
4 MUELLE FRT552

BUJE CÓNICO
P/BALANCÍN
#0075 RPH



CÓDIGO: 2002H
No. MAF: 2002H

MAF

BUJE CÓNICO
P/BALANCÍN C/BUJE
INT.



CÓDIGO: 2002-1T
No. MAF: 2002-1

MAF

PERCHA CENTRAL
REFORZADA



CÓDIGO: SFH0009R
No. MAF: SFH0009-R

MAF

PERCHA CENTRAL



CÓDIGO: SFH0009
No. MAF: SFH0009

MAF

PERCHA TRAS.
REFORZADA



CÓDIGO: SFH0010R
No. MAF: SFH0010-R

MAF

PERCHA TRASERA



CÓDIGO: SFH0010
No. MAF: SFH0010

MAF

PERCHA DELANTERA
REFORZADA



CÓDIGO: SFH0008R
No. MAF: SFH0008-R

MAF

PERCHA DELANTERA



CÓDIGO: SFH0008
No. MAF: SFH0008

MAF

RONDANA P/PERNO
DE BALANCÍN



CÓDIGO: SFH0007
No. MAF: SFH0007

MAF

RONDANA
1 1/16" x 4.00" x 1/4" MAF



CÓDIGO: 0003F
No. MAF: 0003F

MAF

GENERAL MOTORS

CHEVROLET PICK UP
CHEYENNE C10 C15
MODELO 91-95 CT030



14187F
(4282A)



07027
(4219)



20045
(TLF09)

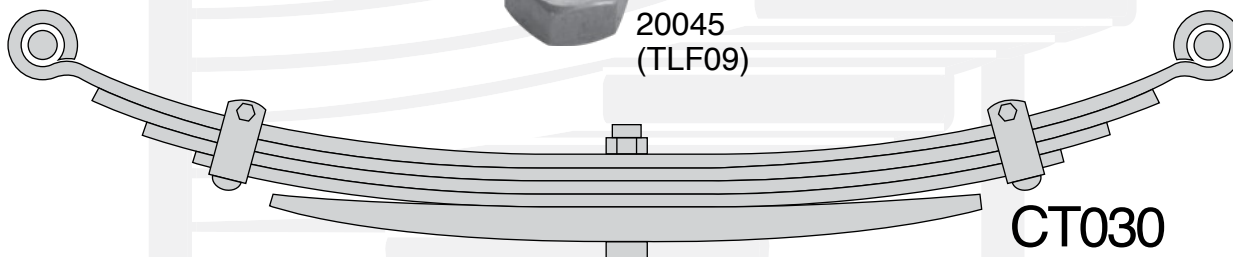

CT030



06079R
(RB-117)



19206
(TC-38-4)



14063F
(4227)

GENERAL MOTORS CHEVROLET PICK UP CHEYENNE C10 C15 MODELO 91-95 CT030

CÓDIGO	No. MAF	DESCRIPCIÓN	CANTIDAD
14187F	4282A	PERCHA TRASERA DELANTERA	2
14063F	4227	PERCHA TRASERA TRASERA	2
07027	4219	COLUMPIO C15	2
20045	TLF09	TUERCA FINA DE 3/8" 02	2
19206	TC-38-4	TORNILLO DE CENTRO 3/8" x 4"	2
06079R	RB117	BUJE FIERRO Y HULE RB-117	4
CT030	CT-030	MUELLE 5 HOJAS 2 1/2" x .401" x 32.00" x 32.00"	2
		ROL 1 1/2" (RB-117) AMBOS LADOS.	2

VER CATÁLOGO DE MUELLES MAF 2011

MUELLES QTR PARA REMOLQUES. (QUALITY TRAILER)

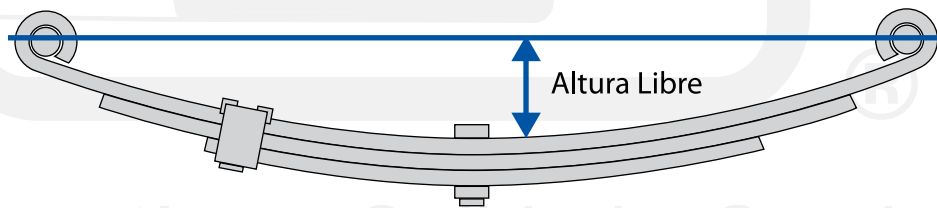

QTR-218 1 3/4" X .360" X 13 5/32" X 13 5/32"
CAPACIDAD 1750 Lbs.

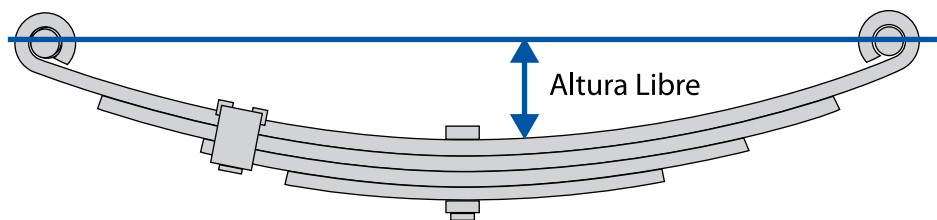

QTR-224 1 3/4" X .360" X 13 5/32" X 13 5/32"
CAPACIDAD 2400 Lbs.

Garantía de Calidad Servicio

GENERAL MOTORS

CHEVROLET PICK UP
CHEYENNE C10 C15
MODELO 91-95 CT030

PERCHA TRASERA
DELANTERA



CÓDIGO: 14187F
No. MAF: 4282A

MAF

PERCHA TRASERA
TRASERA



CÓDIGO: 14063F
No. MAF: 4227

MAF

COLUMPIO



CÓDIGO: 07027
No. MAF: 4219

MAF

TUERCA UNF.
°2 DE 3/8"



CÓDIGO: 20045
No. MAF: TLF09

MAF

TORNILLO CENTRO
DE 3/8" x 6"



CÓDIGO: 19206
No. MAF: TC-38-4

MAF

BUJE FIERRO Y HULE
RB-117



CÓDIGO: 06079R
No. MAF: RB-117

MAF

Garantía en Calidad y Servicio

GENERAL MOTORS
CHEVROLET C30
CHASIS MICROBUS
MODELO 73-94 CT494

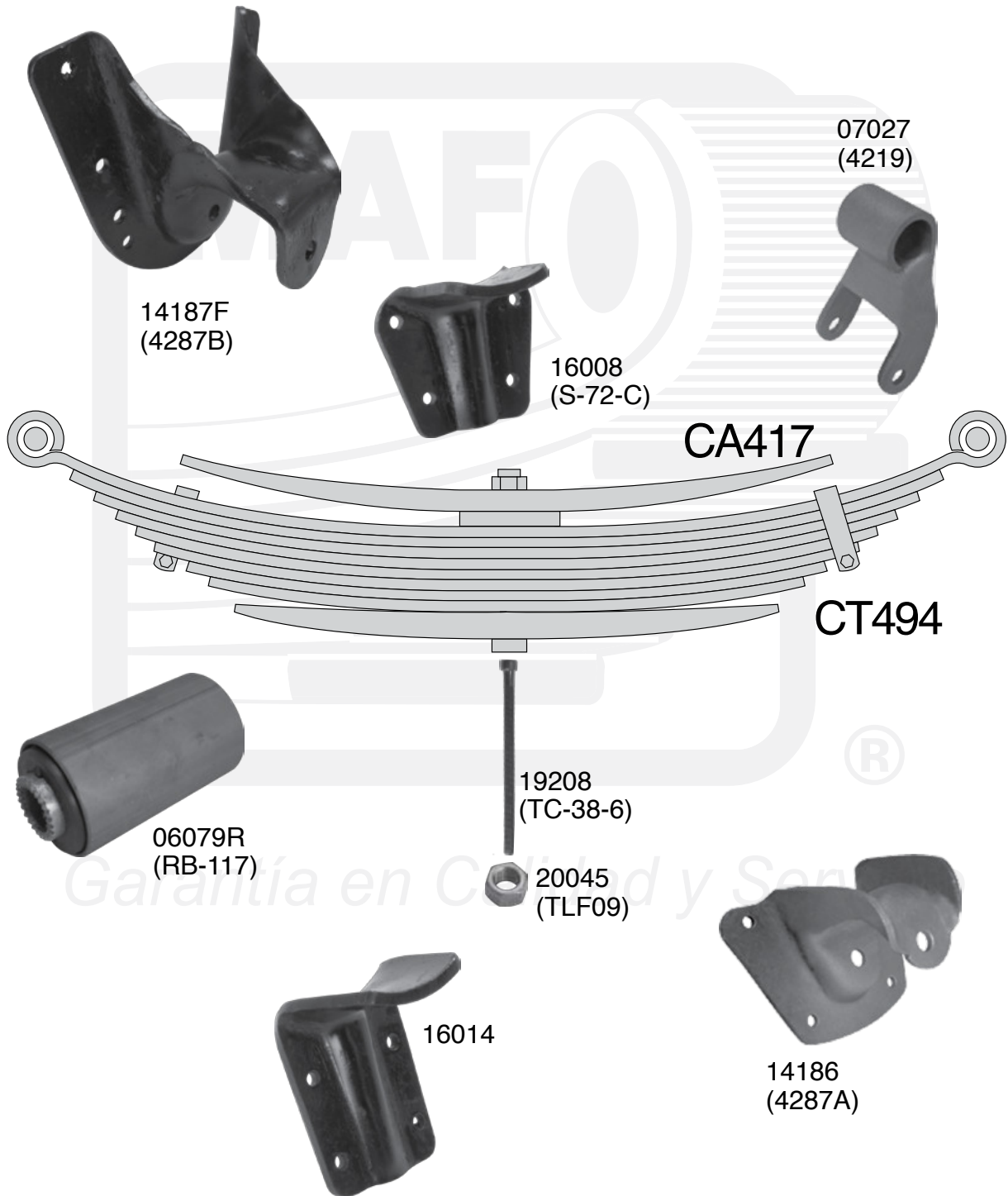

GENERAL MOTORS

CHEVROLET C30 CHASIS MICROBUS MODELO 73-94 CT494

CÓDIGO	No. MAF	DESCRIPCIÓN	CANTIDAD
14186	4287A	PERCHA	2
16008	S-72-C	SOPORTE	2
16014	S-73-D	SOPORTE	2
14187F	4287B	PERCHA	2
07027	4219	COLUMPIO	8
06079R	RB-117	BUJE FIERRO Y GOMA RB-117 = RB-144 = RB-251	2
20045	TLF09	TUERCA HEX. LIVIANA FINA DE 3/8" 02	2
19208	TC-38-6	TORNILLO DE CENTRO 3/8" x 6"	2
CA417-01	CA-417	MUELLE AUXILIAR 1 HOJA 2 1/2. x .625" x 19 5/8" x 19 5/8"	2
CT494	CT-494	MUELLE 7 HOJAS	2
		HOJA 01 2 1/2" x .323" x 26.00" x 26.00"	
		ROL 1 1/2" (RB-117) AMBOS LADOS.	

VER CATÁLOGO DE MUELLES MAF 201

MUELLES PARA TRAILERS

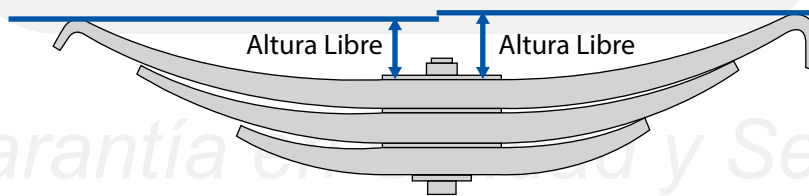

ALTURA LIBRE ALTURA LIBRE
TRA-2727 3" X .788" X 22 1/2" X 22 3/4"

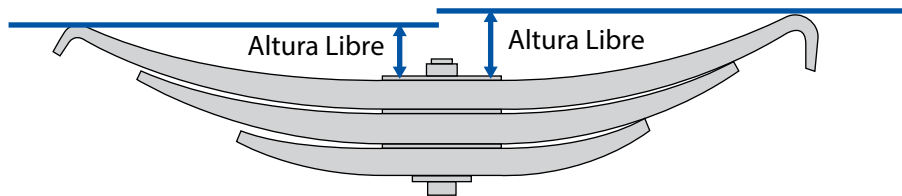

ALTURA LIBRE ALTURA LIBRE
TRA-2727X 3" X .788" X 21 1/2" X 22 3/4"

GENERAL MOTORS

CHEVROLET C30 CHASIS MICROBUS MODELO 73-94 CT494

PERCHA C30



CÓDIGO: 14186
No. MAF: 4287A

MAF

SOPORTE C30



CÓDIGO: 16008
No. MAF: S-72-C

MAF

PERCHA C30



CÓDIGO: 14187F
No. MAF: 4287B

MAF

COLUMPIO C30



CÓDIGO: 07027
No. MAF: 4219

MAF

BIJE FIERRO Y HULE
RB-117



CÓDIGO: 06079R
No. MAF: RB-117

MAF

TUERCA UNF
°2 DE 3/8"



CÓDIGO: 20045
No. MAF: TLF-09

MAF

TORNILLO CENTRO
DE 3/8" x 6"



CÓDIGO: 19208
No. MAF: TC-38-6

MAF

SOPORTE



CÓDIGO: 16014
No. MAF: S-73-D

MAF

Garantía en Calidad y Servicio

GENERAL MOTORS

CHEVROLET C.3500
3 1/2 TON MODELO 97-00
MUELLE CT3500



16040
(S-73-G)
16039
(S-73-F)
16036
(S-73-E)
S73FD



07067F



14206C
(4315)
14111F
(4224 PERCHA)

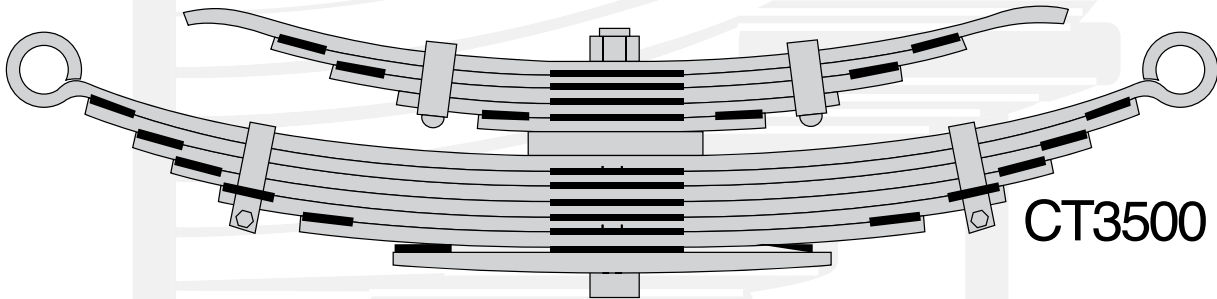

CT3500



06191R
(RB-219)
06098R
(RB-772)



06190R
(RB-218)
06153R
(RB-137)



14110F
(4223)

GENERAL MOTORS

CHEVROLET C.3500

3 1/2 TON MODELO 97-00

MUELLE CT3500

CÓDIGO	No. MAF	DESCRIPCIÓN	CANTIDAD
14206C	4315	PERCHA TRAS. TRAS. HEAVY DUTY 3500 (00-05)	2
14111F	4224	PERCHA TRAS. TRAS. HEAVY DUTY C-3500	2
06191R	RB-219	BUJE FIERRO Y HULE RB-219	2
06190R	RB-218	BUJE FIERRO Y HULE RB-218	2
16040	S-73-G	SOPORTE VULCANIZADO C-3500 HEAVY DUTY	2
16039	S-73-F	SOPORTE VULCANIZADO C-3500 CHEVROLET	2
16036	S-73-E	SOPORTE VULCANIZADO C-3500 CHEVROLET	2
S73FD	S73FD	SOPORTE S-73 FD C-3500 HEAVY DUTY CHEVROLET	2
14110F	4223	PERCHA TRAS. DEL. HEAVY DUTY C-3500	2
06098R	RB-772	BUJE FIERRO Y GOMA RB-772 (COLUMPIO 7194 RAM)	2
06153R	RB-137	BUJE FIERRO Y HULE RB-137	2
07067F	1289=4295	COLUMPIO	2
CT-3500	CT3500	MUELLE COMPLETA T7 HOJAS	2
		HOJA -01 3.00" .499" x 28.00" x 28.00"	

VER CATÁLOGO DE MUELLES MAF 2011

Garantía en Calidad y Servicio

GENERAL MOTORS

CHEVROLET C.3500
3 1/2 TON MODELO 97-00
MUELLE CT3500

PERCHA TRAS. TRAS.



CÓDIGO: 14206C
No. MAF: 4315

MAF

PERCHA TRAS. TRAS.



CÓDIGO: 14111F
No. MAF: 4224

MAF

BUJE FIERRO Y HULE



CÓDIGO: 06191R
No. MAF: RB-219

MAF

BUJE FIERRO Y HULE



CÓDIGO: 06190R
No. MAF: RB-218

MAF

SOPORTE
VULCANIZADO C-3500
HEAVY DUTY



CÓDIGO: 16040
No. MAF: S-73-G

MAF

SOPORTE
VULCANIZADO C-3500
CHEVROLET



CÓDIGO: 16039
No. MAF: S-73-F

MAF

SOPORTE
VULCANIZADO C-3500
CHEVROLET



CÓDIGO: 16036
No. MAF: S-73-E

MAF

SOPORTE
VULCANIZADO C-3500
HEAVY DUTY
CHEVROLET



CÓDIGO: S73FD
No. MAF: S73FD

MAF

PERCHA TRAS. DEL.
HEAVY DUTY C-3500



CÓDIGO: 14110F
No. MAF: 4223

MAF

BUJE FIERRO Y GOMA
RB-772
(COLUMPIO 7194 RAM)



CÓDIGO: 06098R
No. MAF: RB-772

MAF

BUJE FIERRO Y HULE
RB-137



CÓDIGO: 06153R
No. MAF: RB-137

MAF

COLUMPIO



CÓDIGO: 07067F
No. MAF: 1289=4295

MAF

GENERAL MOTORS

CHEVROLET 3500
MODELO 97 - 05
MUELLE 22492

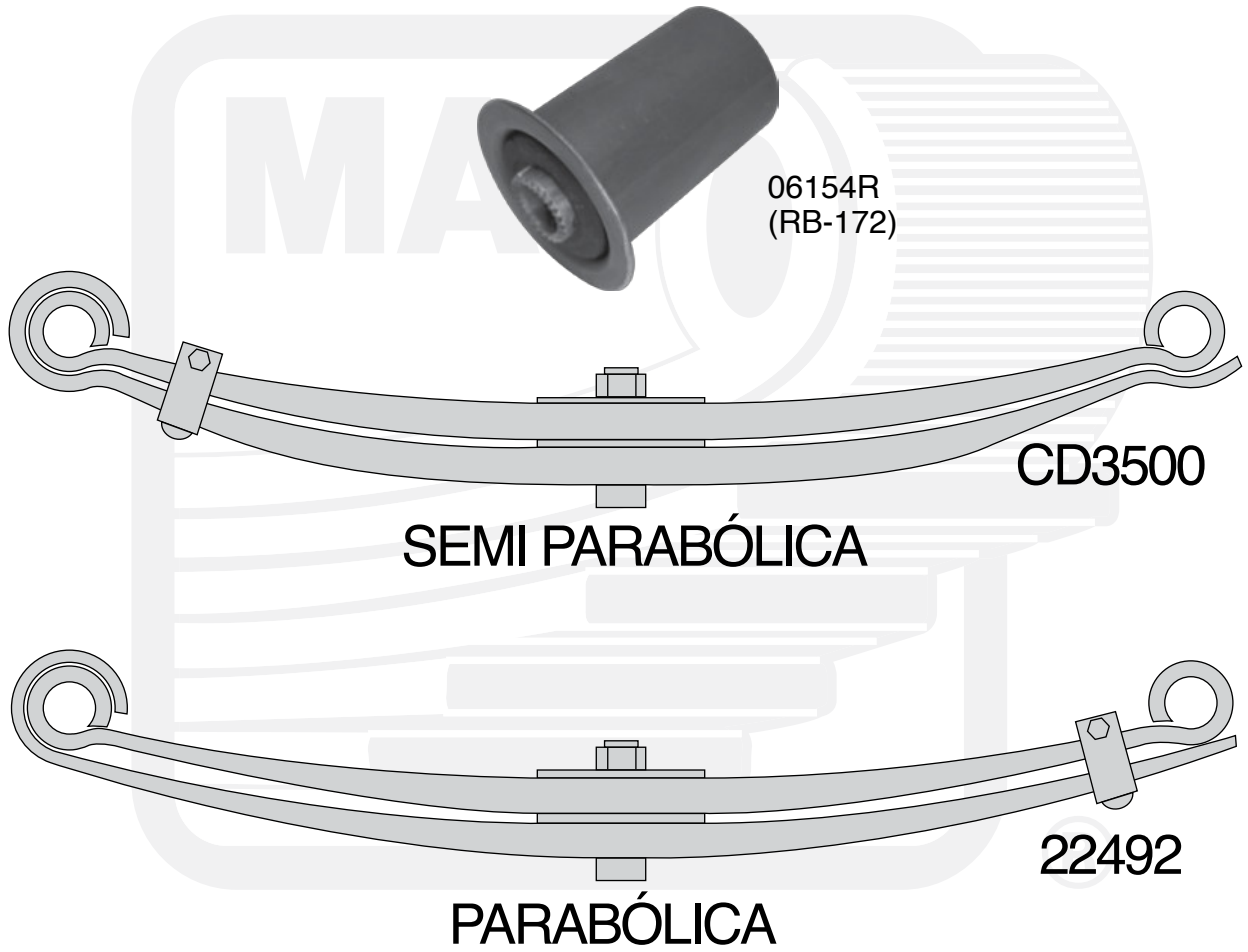

Garantía en Calidad y Servicio



GENERAL MOTORS

CHEVROLET 3500 MODELO 97 - 05 MUELLE 22492

CÓDIGO	No. MAF	DESCRIPCIÓN	CANTIDAD
07067F	1289	COLUMPIO CHEVROLET	2
06154R	RB-172	BUJE FIERRO Y HULE	4
CD3500	CD3500	MUELLE DE 2 HOJAS SEMI-PARABÓLICA	2
		HOJA01 21/2" x .662" x 28 1/2" x 28 1/2"	
22 492	22-492	MUELLE DE 2 HOJAS PARABÓLICA HOJA 01	2
		2 1/2" x .702" x 28 1/2" x 28 1/2"	

VER CATÁLOGO DE MUELLES MAF 2011



Garantía en Calidad y Servicio

GENERAL MOTORS

CHEVROLET C50 C60 C70
MODELO 60 -81 CT309

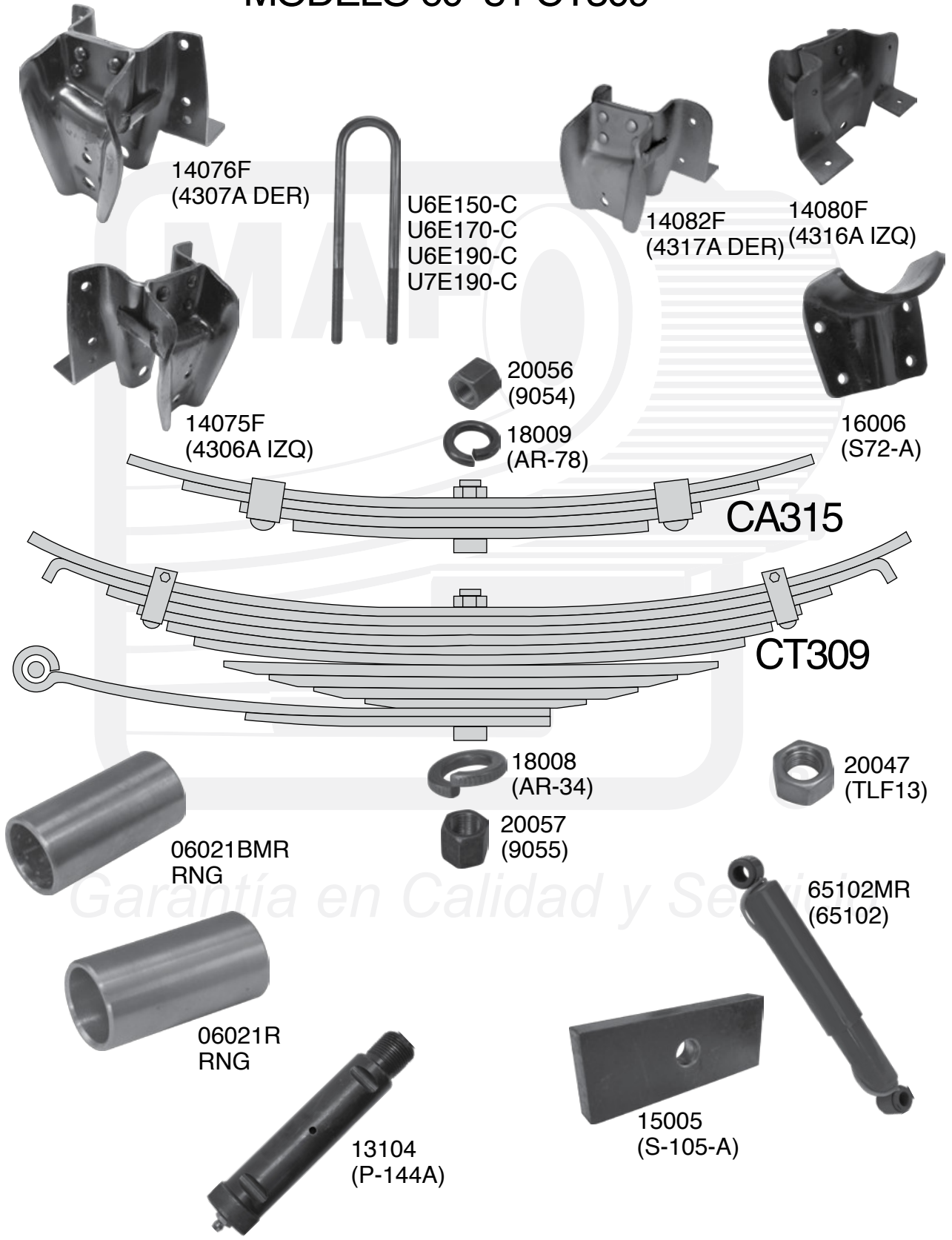

Garantía en Calidad y Servicio

GENERAL MOTORS

CHEVROLET C50 C60 C70
MODELO 60 -81 CT309

CÓDIGO	No. MAF	DESCRIPCIÓN	CANTIDAD
15005	S-105-A	SEPARADOR 3.00" x 7 1/2" x 7/8"	2
14075F	4306-A	PERCHA TRAS. DEL. CHEV. C-50,60 IZQUIERDO	1
14076F	4307-A	PERCHA TRAS. DEL. CHEV. C-50,60 DERECHO	1
14080F	4316-A	PERCHA TRAS. TRAS. CHEV. C50 / C60 IZQUIERDO	1
14082F	4317-A	PERCHA CHEV. TRA. TRAS. C50 / C60 DERECHO	1
16006	S-72-A	SOPORTE CHEV. C50 / C-60 / C65	4
65102 MR	65102	AMORTIGUADOR MONROE=85001	2
U6E150-C	U-6E150-C	TORNILLO "U" 3/4" x 3 1/16" x 15.00"	4
U6E170-C	U-6E170-C	TORNILLO "U" 3/4" x 3 1/16" x 17.00"	4
U6E190-C	U-6E190-C	TORNILLO "U" 3/4" x 3 1/16" x 19.00"	4
U7E190-C	U-7E190-C	TORNILLO "U" 7/8" x 3 1/16" x 19.00"	4
20047	TLF13	TUERCA UNF. °8 DE 1/2" °2	2
20056	9054	TUERCA FINA ALTA DE 3/4" °8	8
20057	9055	TUERCA FINA ALTA DE 7/8" °8	8
18008	AR-34	RONDANA DE PRESIÓN 3/4"	8
18009	AR-78	RONDANA DE PRESIÓN 7/8"	8
06021R	RNG	BUJE BRONCE 1 1/2" x 1 1/4" x 3.00" RNG 252-4	8
06021BMR	RNG	BUJE BI-METÁLICO 1 1/2" x 1.260" x 3.00"	8
13104	P-144A	PERNO 1 1/4" x 5 5/8" (PARA HOJA GUÍA)	2
CA315	CA-315	MUELLE AUXILIAR CA315, 4 HOJAS	2
		HOJA 1ra 3. x.360"x 19 1/2"x 19 1/2"	2
CT309	CT-309	MUELLE COMPLETA CT-309, 12 HOJAS	2
		HOJA 1ra 3. x .401" x 29 5/8" x 29 5/8"	
		HOJA 11a 3. x .447" x 25 1/2" x 3 1/2" CON BUJE RNG	2

VER CATÁLOGO DE MUELLES MAF 2011 .

GENERAL MOTORS

CHEVROLET C50 C60 C70 MODELO 60 -81 CT309

SEPARADOR
3" x 7 1/2" x 3/4"



CÓDIGO: 15005
No. MAF: S-105-A

PERCHA C50 C60
TRAS. DEL. IZQ.



CÓDIGO: 14075F
No. MAF: 4306-A

PERCHA C50 C60
TRAS. DEL. DER.



CÓDIGO: 14076F
No. MAF: 4307-A

PERCHA C50 C60
TRAS. TRAS. IZQ.



CÓDIGO: 14080F
No. MAF: 4316-A

PERCHA C50 C60
TRAS. TRAS. DER.



CÓDIGO: 14082F
No. MAF: 4317-A

SOPORTE
SOBRECARGA



CÓDIGO: 16006
No. MAF: S-72-A

AMORTIGUADOR
MONROE = 85001
MERITOR



CÓDIGO: 65102MR
No. MAF: 65102

TORNILLO "U"
3/4" x 3 1/16" x 15.00"



CÓDIGO: U6E150-C
No. MAF: U-6E150-C

TORNILLO "U"
3/4" x 3 1/16" x 17.00"



CÓDIGO: U6E170-C
No. MAF: U-6E170-C

TORNILLO "U"
3/4" x 3 1/16" x 19.00"



CÓDIGO: U6E190-C
No. MAF: U-6E190-C

TORNILLO "U"
7/8" x 3 1/16" x 19.00"



CÓDIGO: U7E190-C
No. MAF: U-7E190-C

TUERCA FINA ALTA
1/2" 02



CÓDIGO: 20047
No. MAF: TLF13

GENERAL MOTORS

CHEVROLET C50 C60 C70
 MODELO 60 -81 CT309

TUERCA FINA ALTA
 3/4"



CÓDIGO: 20056
 No. MAF: 9054

MAF

TUERCA FINA ALTA
 7/8"



CÓDIGO: 20057
 No. MAF: 9055

MAF

RONDANA DE
 PRESIÓN 3/4"



CÓDIGO: 18008
 No. MAF: AR-34

MAF

RONDANA DE
 PRESIÓN 7/8"



CÓDIGO: 18009
 No. MAF: AR-78

MAF

BUJE BRONCE
 1 1/2" x 1 1/4" x 3.00"



CODIGO: 06021R
 No. MAF: RNG

MAF

BUJE BI-METÁLICO
 1 1/2" x 1.260" x 3.00"



CODIGO: 06021BMR
 No. MAF: RNG

MAF

PERNO 1 1/4" x 5 5/8"
 PARA GUÍA



CÓDIGO: 13104
 No. MAF: P-144A

MAF

Garantía en Calidad y Servicio

GENERAL MOTORS
CHEVROLET KODIAK
MODELO 95-00 MUELLE CT845

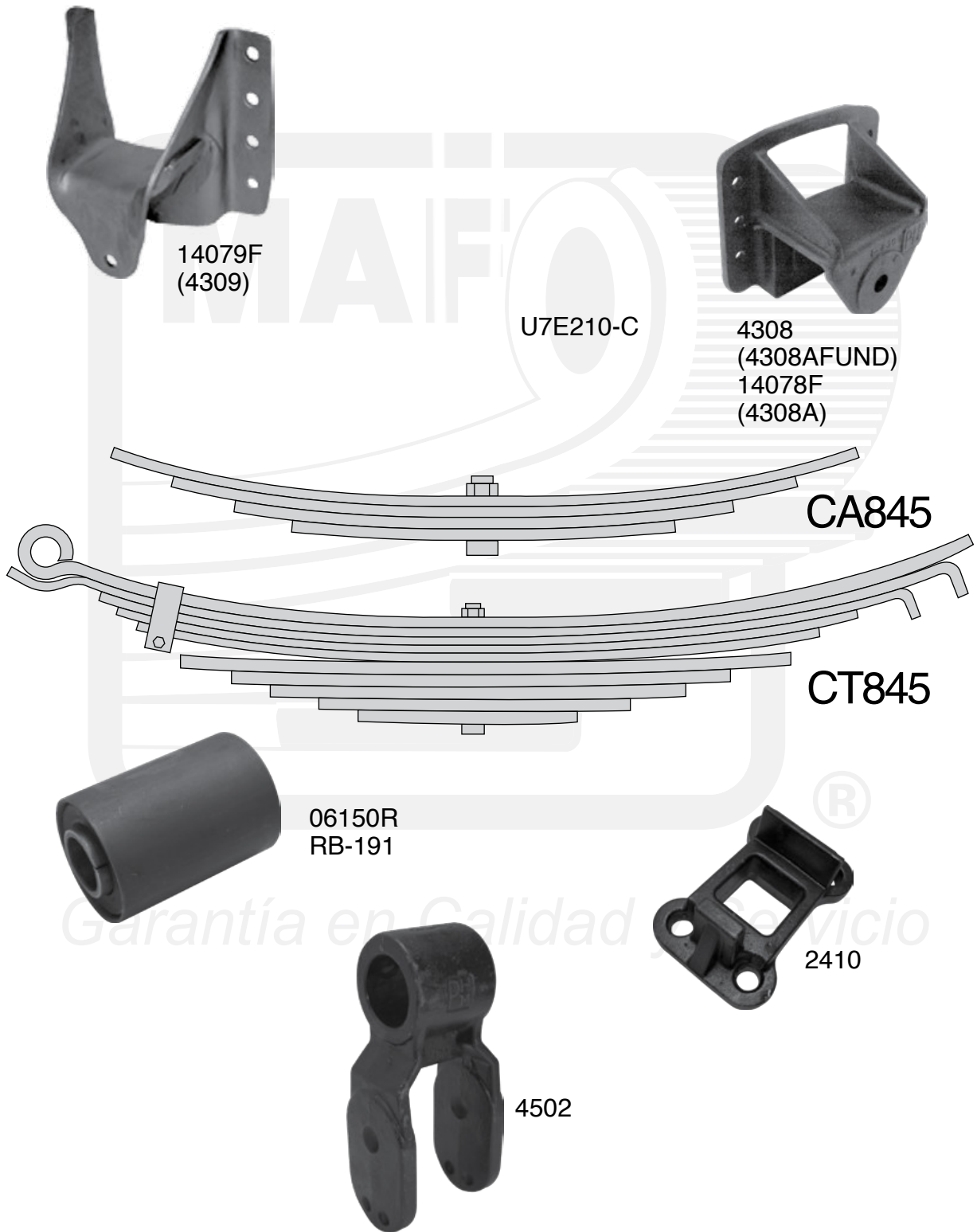

GENERAL MOTORS

CHEVROLET KODIAK

MODELO 95-00 MUELLE CT845

CÓDIGO	No. MAF	DESCRIPCIÓN	CANTIDAD
14079F	4309	PERCHA KODIAK TRAS. TRAS. MODELO 96-04 TAPA	2
2410	2410	INFERIOR PARA SUSP. KODIAK	2
14078A	4308A	PERCHA C/ROLD. LADO INT. KODIAK TRAS. DEL. 95	2
4308AF	4308	PERCHA CHEV KODIAK TRAS DEL#15641040 6 HOYOS	2
4502	4502	PERCHA COLUMPIO KODIAK SUSP. TRAS.	2
U7E210-C	U7E210-C	TORNILLO "U" 7/8" x 3 1/16" x 21.00"	2
2411	2411	CUÑA PARA SUSPENSIÓN KODIAK	2
4502	4502	PERCHA COLUMPIO KODIAK SUSPENSIÓN TRAS.	2
06150R	RB-191	BUJE FIERRO Y HULE.	2
CT845	CT-845	MUELLE 10 HOJAS	2
		HOJA 01 3" x .662" x 29 13/16" x 33 3/8"	

VER CATÁLOGO DE MUELLES MAF 2011

MUELLES QTR PARA REMOLQUES. (QUALITY TRAILER)

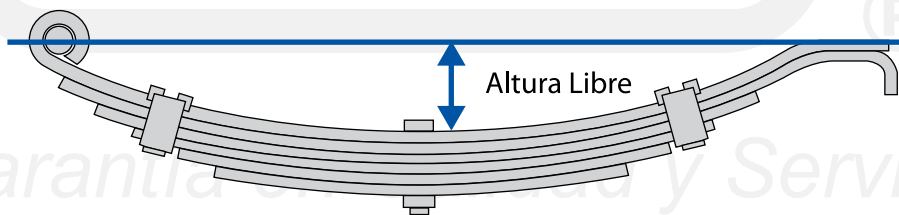

QTR-361m 2" X .323" X 14 1/4" X 16 3/8"

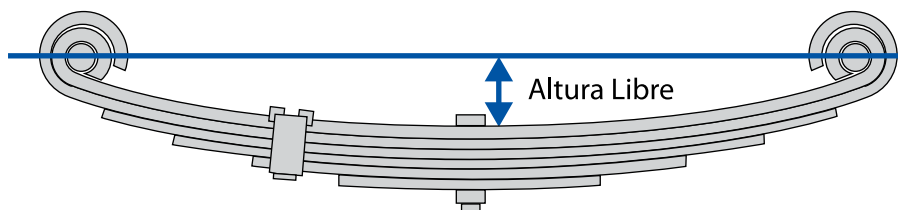

QTR-352 1 3/4" X .360" X 13 5/32" X 13 5/32"
CAPACIDAD 2900 Lbs.

GENERAL MOTORS

CHEVROLET KODIAK

MODELO 95-00 MUELLE CT845



Garantía en Calidad y Servicio

HENDRICKSON

SUSPENSIÓN HENDRICKSON

HAS 360/400/402



4008



56557002R



U-6E160-C
U-7E160-C



64336 S/SOP
64265 C/SOP
(CONTITECH)



0016

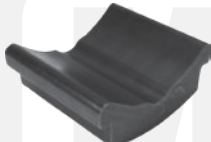

56929000R



5018



1R12403
1R12402



57356001R

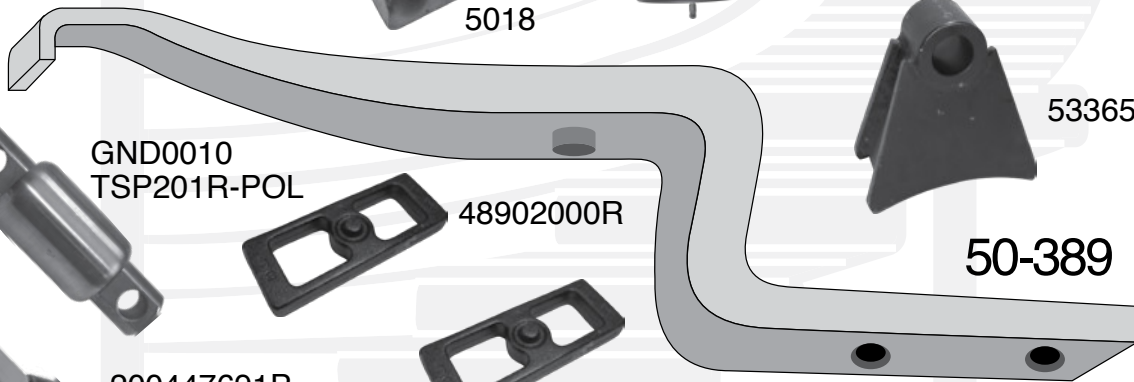

50-389



53365000R



GND0010
TSP201R-POL



48902000R



2149



200447691P



48903000R



5017



56805000R



60826000R



TSP201R-HUL
810096 CLEVITE

60215000R



GND0010B



4052
4053
4054
4055



4009
A,B,C,D,E,
F,G,H



60218000R

85013A MERITOR
65401MR MONROE



S017



57317001R

SND0001



HENDRICKSON

SUSPENSIÓN HENDRICKSON HAS 360/400/402

CÓDIGO	No. MAF	DESCRIPCIÓN	CANTIDAD
85013A	85013	AMORTIGUADOR MERITOR=65401 MONROE	2
65401MR	65401	AMORTIGUADOR MONROE = 85013 MERITOR	2
57356001R	57356-000	SOPORTE INFERIOR P/AMORTIG. TIPO 1	2
48902000R	48902-000	ESPACIADOR DE 1.00" HENDRICKSON	2
48903000R	48903-000	ESPACIADOR DE 1 1/2" HENDRICKSON	2
2149	2149	ASIENTO DE MUELLE HEND. 3" x 1 1/2" x 7 3/4"	2
200447691P	200-447691P	HEND P/B TORSIÓN TSP201R-POL	2
810096	810096	P/B TORSIÓN TSP201R-HUL # ORIG. 47691 CLEVITE	2
GND0010	GND-0010	GRANADA E-4 NORMAL	4
GND0010B	GND0-010B	GRANADA E-4 C/*CASQUILLO	4
TSP201R-HUL	200-447691	GRANADA IARSA No.154 P/BARRA TORSIÓN	4
TSP201R-POL	TSP201R	GRANADA13521=47691 HEND. P/BARRA TORSIÓN	4
4052	4052	TAPA INFERIOR HAS No. ORIGINAL 50216 D	2
4053	4053	TAPA INFERIOR HAS No. ORIGINAL 50222 D	2
4054	4054	TAPA INFERIOR HAS No. ORIGINAL 50217 D	2
4055	4055	TAPA INFERIOR HAS No. ORIGINAL 50221 D	2
4009	4009	ASIENTO EJE Y SOPORTE TENSOR SUSP. HAS	2
4009A	4009A	ASIENTO EJE Y SOPORTE TENSOR SUS.	2
4009B	4009B	ASIENTO. EJE Y SOP. TEN. SUSP. MAQ. 6 GDO.	2
4009C	4009C	ASIENTO EJE Y SOP. TEN. SUSP. MAQ 5.5 GDO	2
4009D	4009D	ASIENTO EJE Y SOP. TEN. SUSP. MAQ. 3.5 GDO	2
4009E	4009E	ASIENTO EJE Y SOP. TEN. SUSP. MAQ.10.5 GDO	2
4009F	4009F	ASIENTO EJE Y SOPORTE TENSOR 2.5 GRADOS	2
4009G	4009G	ASIENTO EJE Y SOPORTE TENSOR 11.5 GRADOS	2
4009H	4009H	ASIENTO EJE Y SOPORTE TENSOR SUSP. AQ. °12	2
56929000R	56929-000	COJINETE DESLIZANTE PLÁSTICO HEND.	2
53365000R	53365-000	SOPORTE P/BARRA TORSIÓN TRANSVER. HEND.	2
60215000R	60125-000	B/TORSIÓN TRANSV. CÓNICA ULTRA ROD. AJUS.	2
60218000R	60218-000	B/TORSIÓN TRANSV. ESTILO ESPARRAGO	2

HENDRICKSON SUSPENSIÓN HENDRICKSON HAS 360/400/402

CÓDIGO	No. MAF	DESCRIPCIÓN	CANTIDAD
SND0001	22186000R	SOPORTE P/BRAZO DE TORSIÓN DINA 881	2
4008	4008	PERCHA PARA SUSPENSIÓN HAS AIRE FUND.	2
56557002R	56557-002	COJINETE DESLIZANTE PLÁSTICO HEND.	2
60826000R	60826-000	VÁLVULA NIVELADORA 48651-002(50433-001)	1
U6E160-C	U-6E160-C	TORNILLO "U" 3/4" x 3 1/16" x 16.00"	4
U7E160-C	U-7E160-C	TORNILLO "U" 7/8" x 3 1/16" x 16.00"	4
1R12402	1R12402	BOLSAS DE AIRE DE SUSPENSIÓN W01-358-9296	2
1R12403	1R12403	AIR SPRING GOODYEAR	2
64265	64265	BOLSA DE AIRE C/SOPORTE	2
64336	65336	BOLSA DE AIRE C/SOPORTE	2
5017	5017	SOPORTE AMORTIGUADOR FUNDICIÓN HEND.	2
57317001R	57317-001	CANAL TRANSVERSAL	1
56805000R	56805-000	TAPA SUPERIOR	2
5018	5018	ASIENTO DE ABRAZADERA HEND. HAS 360/400	2
0016	0016	RONDANA ESFÉRICA DE 7/8" FUNDICIÓN PHM	2
S017	S017	CANGREJO DE AJUSTE 1/16" x 4 3/8"	2
50389	50-389	MUELLE TIPO "Z" 3" x 2" x 24" x 19 5/8"	2

PARA MAYORES DETALLES DE ESPESORES

ESPECIALES VER CATÁLOGO DE MUELLES 2011

Garantía en Calidad y Servicio

HENDRICKSON

SUSPENSIÓN HENDRICKSON HAS 360/400/402

AMORTIGUADOR
MONROE = 65401
MERITOR



CÓDIGO: 85013A
No. MAF: 85013

AMORTIGUADOR
MONROE = 85013
MERITOR



CÓDIGO: 65401MR
No. MAF: 65401

SOPORTE INFERIOR
P/AMORT. TIPO 1



CÓDIGO: 57356001R
No. MAF: 57356-000

ESPACIADOR
DE 1.00



CÓDIGO: 48902000R
No. MAF: 48902-000

ESPACIADOR
DE 1 1/2"



CÓDIGO: 48903000R
No. MAF: 48903-000

ASIENTO
3" x 1 1/2" x 7 3/4" PHM



CÓDIGO: 2149
No. MAF: 2149

GRANADA PARA
TENSOR 2"



CÓDIGO: 200447691P
No. MAF: 200-447691P

GRANADA PARA
TENSOR 2" HULE
CLEVITE



CÓDIGO: 810096
No. MAF: 810096

GRANADA PARA
TENSOR 2" HULE



CÓDIGO: GND0010
No. MAF: GND-0010

GRANADA P/TENSOR
2" C/CASQUILLOS



CÓDIGO: GND0010B
No. MAF: GND0-010B

GRANADA P/TENSOR 2"
HULE IARSA



CÓDIGO: TSP201R-HUL
No. MAF: 200-447691

GRANADA P/TENSOR
2"



CÓDIGO: TSP201R-POL
No. MAF: TSP201R

HENDRICKSON SUSPENSIÓN HENDRICKSON HAS 360/400/402

TAPA INFERIOR HAS
No. ORIGINAL
50216 D



CÓDIGO: 4052
No. MAF: 4052

MAF

TAPA INFERIOR HAS
No. ORIGINAL
50222 D



CÓDIGO: 4053
No. MAF: 4053

MAF

TAPA INFERIOR HAS
No. ORIGINAL
50217 D



CÓDIGO: 4054
No. MAF: 4054

MAF

TAPA INFERIOR HAS
No. ORIGINAL
50221 D



CÓDIGO: 4055
No. MAF: 4055

MAF

ASIENTO EJE Y
SOPORTE TENSOR



CÓDIGO: 4009
No. MAF: 4009

MAF

ASIENTO EJE Y
SOPORTE TENSOR
MAQUINADO A 9°



CÓDIGO: 4009A
No. MAF: 4009A

MAF

ASIENTO EJE Y
SOPORTE TENSOR
MAQUINADO A 6°



CÓDIGO: 4009B
No. MAF: 4009B

MAF

ASIENTO EJE Y
SOPORTE TENSOR
MAQUINADO A 5.5°



CÓDIGO: 4009C
No. MAF: 4009C

MAF

ASIENTO EJE Y
SOPORTE TENSOR
MAQUINADO A 3.5°



CÓDIGO: 4009D
No. MAF: 4009D

MAF

ASIENTO EJE Y
SOPORTE TENSOR
MAQUINADO A 10.5°



CÓDIGO: 4009E
No. MAF: 4009E

MAF

ASIENTO EJE Y
SOPORTE TENSOR
MAQUINADO A 2.5°



CÓDIGO: 4009F
No. MAF: 4009F

MAF

ASIENTO EJE Y
SOPORTE TENSOR
MAQUINADO A 11.5°



CÓDIGO: 4009G
No. MAF: 4009G

MAF

HENDRICKSON

SUSPENSIÓN HENDRICKSON HAS 360/400/402

ASIENTO EJE Y
SOPORTE TENSOR
MAQUINADO A 12°



CÓDIGO: 4009H
No. MAF: 4009H

COJINETE
DESGLIZANTE
PLÁSTICO HEND.



CÓDIGO: 56929000R
No. MAF: 56929-000

SOPORTE P/BARRA
TORSIÓN



CÓDIGO: 53365000R
No. MAF: 53365-000

TRANVER. HEND.



CÓDIGO: 60215000R
No. MAF: 60215-000

B/TORSIÓN TRANSV.
CÓNICA ULTRA ROD.
AJUS.



CÓDIGO: 60218000R
No. MAF: 60218-000

SOPORTE P/BRAZO
DE TORSIÓN



CÓDIGO: SDN0001
No. MAF: SDN0001 =
22186000R

PERCHA
FUNDICIÓN



CÓDIGO: 4008
No. MAF: 4008

COJINETE
DESGLIZANTE
PLÁSTICO HEND



CÓDIGO: 56557002R
No. MAF: 56557-002

VÁLVULA NIVELADORA
48651-002
(50433-001)



CÓDIGO: 60826000R
No. MAF: 60826-000

TORNILLO "U"
3/4" x 3 1/16" x 16.00"



CÓDIGO: U6E160-C
No. MAF: U-6E160-C

TORNILLO "U"
7/8" x 3 1/16" x 16.00"



CÓDIGO: U7E160-C
No. MAF: U-7E160-C

AIR SPRING
GOODYEAR



CÓDIGO: 1R12402
No. MAF: 1R12402

HENDRICKSON

SUSPENSIÓN HENDRICKSON HAS 360/400/402

BOLSA DE AIRE DE
SUSP. W01-358-9296



CÓDIGO: 1R12403
No. MAF: 1R12403

MAF

BOLSA DE AIRE
CON SOPORTE



CÓDIGO: 64265
No. MAF: 64265

MAF

BOLSA DE AIRE
SIN SOPORTE



CÓDIGO: 64336
No. MAF: 64336

MAF

SOPORTE AMORT.
FUNDICIÓN



CÓDIGO: 5017
No. MAF: 5017

MAF

CANAL
TRANSVERSAL



CÓDIGO: 57317001R
No. MAF: 57317-001

MAF

TAPA SUPERIOR
HENDRICKSON



CÓDIGO: 56805000R
No. MAF: 56805-000

MAF

ASIENTO DE
ABRAZADERA



CÓDIGO: 5018
No. MAF: 5018

MAF

RONDANA ESFÉRICA
7/8" FUNDICIÓN



CÓDIGO: 0016
No. MAF: 0016

MAF

CANGREJO DE
AJUSTE



CÓDIGO: S017
No. MAF: S017

MAF

Garantía en Calidad y Servicio

HENDRICKSON

SUSPENSIÓN HENDRICKSON E4-360 MUELLE DIT600



HENDRICKSON

SUSPENSIÓN HENDRICKSON
E4-360 MUELLE DIT600

CÓDIGO	No. MAF	DESCRIPCIÓN	CANTIDAD
5005	PCH0124	PERCHA TRASERA DELANTERA (5510)	2
5502B	5502B	PERCHA DEL. E-4 TIPO AMERICANO	2
PCH0124	PCH0124	PERCHA TRAS. DEL. SUSPENSIÓN PHM	2
5003	PCH0113	PERCHA TRASERA CENTRAL	2
PCH0113	PCH0113	PERCHA TRASERA CENTRAL PHM 5003	2
5003A	5003A	PERCHA TRASERA CENTRAL TIPO AMERICANO	2
PCH0121	PCH0121	CANDADO "O" ESLABÓN DEL. IZQ. HEND (E-4)	2
PCH0122	PCH0122	CANDADO "O" ESLABÓN DEL. DER. HEND (E-4)	2
5004	PCH0123	PERCHA TRASERA TRASERA E-4 ACERO	2
PCH0123	PCH0123	PERCHA TRASERA TRASERA PHM	2
T8F13127	T8F13127	TORNILLO °8 NF 1/2" x 5 C/T CA. GRIPCO °8	4
T8F16114	T8F16114	TORNILLO °8 UNC. DE 5/8" x 4 1/2"	4
T8F22152	T8F22152	TORNILLO °8 UNC. DE 7/8" X 6	4
T8F25178	T8F25178	TORNILLO °8 NF1" x 7" C/TCA GRIPCO °8	4
7011	7011	TORNILLO PARA GRILLETE E-4 DE 7/8"	4
MHS60F	MHS60F	PLACA SEGURO . 5" ENTRE CENTROS	2
BLN0011	BLN0011	BALANCÍN P/SUSPENSIÓN	2
U7E170-C	U-7E170-C	TORNILLO "U" 7/8" x 3 1/16" x 17.00"	8
U7E160-C	U-7E160-C	TORNILLO "U" 7/8" x 3 1/16" x 16.00"	8
MP8711	MP-871-1	TASA PARA BALANCÍN CHICA	2
MP8712	MP-871-2	TASA PARA BALANCÍN GRANDE	2
06344R	RB-2000-1018	BUJE CENTRAL P/BALANCÍN ORIG. 47420	2
GNL0039	GNL-0039	BUJE CENTRAL E-4	2
1034T	1034	BUJE CENTRAL BALANCÍN 47420	2
MP878	MP-878	BUJE CENTRAL P/BALANCÍN	2
06160R	RB-167	BUJE FIERRO Y HULE	2
1035T	1035	BUJE LATERAL BALANCÍN E-4 47421	2
20047421P	200-4721P	BUJE LATERAL P/BALANCIN POLIUR. RB-167	2
GNL0040	GNL-0040	BUJE LATERAL	2

HENDRICKSON

SUSPENSIÓN HENDRICKSON E4-360 MUELLE DIT600

CÓDIGO	No. MAF	DESCRIPCIÓN	CANTIDAD
MP879	MP-879	BUJE LATERAL P/BALANCÍN	2
8797	8797	SOBRE MUELLE PARA SUSPENSIÓN	2
2700	2700	KIT BUJE CENTRAL PARA SUSPENSIÓN	2
2701	2701	KIT BUJE LATERAL PARA SUSPENSIÓN	2
S017	S017	CANGREJO DE AJUSTE 1/16" x 4 3/8"	2
5189	5189	TENSOR FIJO TRASERO P/SUSPENSIÓN E-4 DE 22"	2
47692000R	47692-000	BUJE PARA BARRA DE TORSIÓN	2
200447691P	200-44791P	HEND P/B TORSIÓN	2
810096	810096	P/B TORSIÓN L # ORIG. 47691 CLEVITE	2
GND0010B	GND-0010B	GRANADA E-4 C/CASQUILLO	2
GND0010	GND-0010	GRANADA E-4 NORMAL	2
TS9201R-HUL	200-447691	P/BARRA TORSIÓN	2
TSP201R-POL	TSP201R	P/BARRA TORSIÓN	2
0016	0016	RONDANA ESFÉRICA DE 7/8" FUNDICIÓN PHM	2
DIT600	DIT-600	MUELLE DE 9 HOJAS	2
		HOJA 01 3" x .558" x 18 7/8" x 23 7/16" CON BUJE RB- 167	

VER CATÁLOGO DE MUELLES 2011



Garantía en Calidad y Servicio

HENDRICKSON

SUSPENSIÓN HENDRICKSON E4-360 MUELLE DIT600

PERCHA DEL. TRAS.
DINA 995 CAPRE
(IMO-561)



CÓDIGO: 5005
No. MAF: 5005

MAF

PERCHA TRAS. DEL.
SUSP. HEND. E-4 PHM



CÓDIGO: 5502B
No. MAF: 2013

MAF

PERCHA TRAS. DEL.
SUSP. HEND. E-4 PHM



CÓDIGO: PCH0214
No. MAF: PCH0214

MAF

PERCHA TRAS.
CENTRAL HEND. E-4



CÓDIGO: 5003
No. MAF: 5003

MAF

PERCHA TRAS.
CENTRAL HEND. E-4
PHM 5003



CÓDIGO: PCH0113
No. MAF: PCH0113

MAF

PERCHA CENTRAL E-4
TIPO AMERICANO



CÓDIGO: 5003A
No. MAF: 5003A

MAF

CANDADO ES LABÓN
DEL. IZQ. HEND (E-4)



CÓDIGO: PCH0121
No. MAF: PCH0121

MAF

CANDADO ES LABÓN
DEL. DER. HEND (E-4)



CÓDIGO: PCH0122
No. MAF: PCH0122

MAF

PERCHA TRAS. TRAS.
E-4 ACERO



CÓDIGO: 5004
No. MAF: 5004

MAF

PERCHA TRAS. TRAS.
SUSP. HEND. E-4 PHM



CÓDIGO: PCH0123
No. MAF: PCH0123

MAF

TORN. °8 NF 1/2" x 5"
C/TCA GRIPCO °8



CÓDIGO: T8F13127
No. MAF: T8F13127

MAF

TORN. °8 UNC DE
5/8" x 4 1/2"



CÓDIGO: T8F16114
No. MAF: T8F16114

MAF

HENDRICKSON

SUSPENSIÓN HENDRICKSON E4-360 MUELLE DIT600

TORNILLO Ø8
UNC DE 7/8" x 6"



CÓDIGO: T8F22152
No. MAF: T8F22152

TORNILLO Ø8
NF 1" x 7"
C/TCA GRIPCO



CÓDIGO: T8F25178
No. MAF: T8F25178

TORNILLO PARA
GRILLETE E-4 DE 7/8"



CÓDIGO: 7011
No. MAF: 7011

PLACA SEGURO HEND.
5" ENTRE CENTROS



CÓDIGO: MHS60F
No. MAF: MHS60F

BALANCÍN P/SUSP.
E-4



CÓDIGO: BLN0011
No. MAF: BLN0011

TORNILLO "U"
7/8" x 3 1/16" x 17.00"



CÓDIGO: U7E170-C
No. MAF: U-7E170-C

TORNILLO "U"
7/8" x 3 1/16" x 16.00"



CÓDIGO: U7F160-C
No. MAF: U-7F160-C

TASA P/BALANCÍN
CHICA E4



CÓDIGO: MP8711
No. MAF: MP-871-1

TASA P/BALANCÍN
CHICA E4



CÓDIGO: MP8711
No. MAF: MP-871-1

BUJE CENTRAL PARA
BALANCÍN



CÓDIGO: 06344R
No. MAF: RB-120-58

BIJE CENTRAL PARA
BALANCÍN



CÓDIGO: GNL0039
No. MAF: GNL0039

BUJE CENTRAL
BALANCÍN



POLIURITECH
CÓDIGO: 1034T
No. MAF: 1034

HENDRICKSON SUSPENSIÓN HENDRICKSON E4-360 MUELLE DIT600

BUJE CENTRAL
P/BALANCÍN



CÓDIGO: MP878
No. MAF: MP-878

MAF

BUJE FIERRO
Y HULE



IARSA
CÓDIGO: 06160R
No. MAF: RB-167

MAF

BUJE LATERAL
BALANCÍN E-4
47421



POLIURITECH
CÓDIGO: 1035T
No. MAF: 1035

MAF

BUJE LATERAL
P/BALANCÍN POLIUR.
RB-167



PARBO
CÓDIGO: 200474221P
No. MAF: 200-474221P

MAF

BUJE LATERAL



CÓDIGO: GNL0040
No. MAF: GNL0040

MAF

BUJE LATERAL
P/BALANCÍN



MIG
CÓDIGO: MP879
No. MAF: MP-879

MAF

SOBRE MUELLE
P/SUSPENSIÓN



CÓDIGO: 8797
No. MAF: 8797

MAF

RONDANA ESFÉRICA
7/8" FUNDICIÓN



CÓDIGO: 0016
No. MAF: 0016

MAF

KIT BUJE LATERAL
P/SUSPENSIÓN



CÓDIGO: 2701
No. MAF: 2701

MAF

CANGREJO DE
AJUSTE



CÓDIGO: S017
No. MAF: S017

MAF

TENSOR FIJO TRA.
P/SUSP. E-4 DE 22"



CÓDIGO: 5189
No. MAF: 5189

MAF

BUJE PARA BARRA
DE TORSIÓN



CÓDIGO: 47692000R
No. MAF: 47692-000

MAF

HENDRICKSON

SUSPENSIÓN HENDRICKSON E4-360 MUELLE DIT600

HEND. P/B TORSIÓN



CÓDIGO: 200447691P
No. MAF: 200447691P
MAF

P/B. TORSIÓN L #
ORIG. 47691 CLEVITE



CÓDIGO: 810096
No. MAF: 810096
MAF

GRANADA E-4
C/CASQUILLO



CÓDIGO: GND0010B
No. MAF: GND-0010B
MAF

GRANADA E-4
NORMAL



CÓDIGO: GND0010
No. MAF: GND-0010
MAF

P/BARRA TORSIÓN



CÓDIGO: TS9201R-HUL
No. MAF: 200-447691
MAF

P/BARRA TORSIÓN



CÓDIGO: TS9201R-POL
No. MAF: TSP201R
MAF

Garantía en Calidad y Servicio

KENWORTH

KENWORTH SUSPENSIÓN BIG SIX MUELLE KWT912



TSP171R-HUL
TSP172R-HUL
2001479P PARBO



2482



TKW0009
TIPO VIEJO



TSP171R-POL
TSP172R-POL

U9G090-B
U9G100-B



TKW0037



TKW0033



20047244

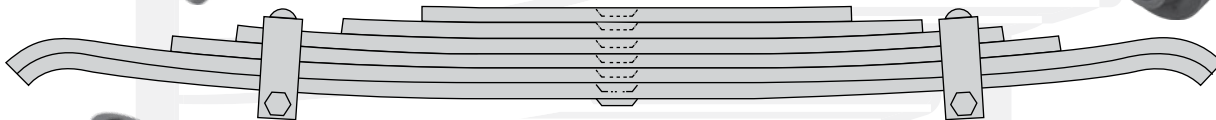

KWT912



TKW0007

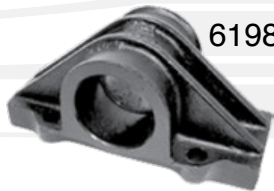

6198



TKW0018



6203

TKW0008
9002



TKW0006



TKW0024



TKW0025



TRW0019



1002T



TKW18KIT



TKW0021



TKW0020



1016T

KENWORTH

KENWORTH SUSPENSIÓN BIG SIX MUELLE KWT912

CÓDIGO	No. MAF	DESCRIPCIÓN	CANTIDAD
2001479P	200-1479P	BUJE PARA BARRA DE TORSIÓN	12
TSP171R-HUL	200-1397	BUJE PARA BARRA DE TORSIÓN	12
TSP171R-POL	TSP171R	BUJE PARA BARRA DE TORSIÓN	12
TSP172R-HUL	200-1479	BUJE PARA BARRA DE TORSIÓN	12
TSP172R-POL	TSP172R	BUJE PARA BARRA DE TORSIÓN	12
2482	2482	SOPORTE DE GRANADA KENWORTH	4
U9G090-B	U-9G090-B	TORNILLO "U" 1 1/8" x 4 1/16" x 9.00"	4
U9G100-B	U-9G100-B	TORNILLO "U" 1 1/8" x 4 1/16" x 10.00"	4
TKW0037	TKW0037	SOBRECAMA DE MUELLE KW T-800 PHM 7206	2
TKW0033	TKW0033	SOPORTE SUP. P/BRAZO DE T.KW T-800 (OREJAS)	4
TKW0007	TKW0007	CAMISA PARA BURRO KENWORTH W-900	2
TKW0018	TKW0018	FLECHA DE 1 1/2" x 22" (BARRA) PHM 6200	2
TKW0019	TKW0019	TUERCA DE COMPRESIÓN PHM 0030	2
TKW0020	TKW0020	CONTRATUERCA PHM 0029	2
TKW18KIT	TKW18-KIT	CONJ. FLECHA TKW0018, TKW0019,TKW0020	2
TKW0021	TKW0021	RONDANA DE BRONCE	2
TKW0008	TKW0008	RONDANA ESCALONADA KW W-900	2
1002T	1002	BUJE P/SUSPENSIÓN CENTRAL.	2
6198	6198	CHUMACERA KW TIPO BIG. 6	2
TKW0006	TKW0006	MUÑÓN DE APOYO KW W-900 FUNDICIÓN	2
1016T	1016	BUJE P/SUSP. CENTRAL TIPO VIEJO KENWORTH	2
9002	9002	RONDANA . ESCALONADA D.E. 5 3/4"D.I 3 1/2"	2
TKW0024	TKW-0024	MUÑÓN DE APOYO KW T-800 FUNDICIÓN	2
6203	6203	AGUJA KENWORTH 1 1/2" x 6" C/TUERCAS P/ T800	2
TKW0025	TKW0025	ESPIGA DE MUÑÓN KW T-800 (USILLO)	2
TKW0009	TKW0009	SOPORTE DE ARTICULACIÓN KW W-900	2
20047244	200-47244	BUJE P/TENSOR KW BIG SIX, ROCKWELL	2
KWT912	KWT-912	MUELLE 6 HOJAS	2
		HOJA -01 4" x .999" x 30 1/2" x 30 1/2"	

VER CATÁLOGO DE MUELLES MAF 2011

KENWORTH

KENWORTH SUSPENSIÓN BIG SIX MUELLE KWT912

BUJE PARA BARRA
DE TORSIÓN

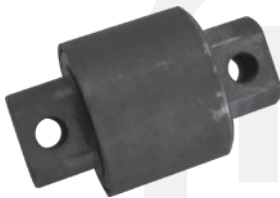

CÓDIGO: 2001479P
No. MAF: 200-1479P

MAF

BUJE PARA BARRA
DE TORSIÓN



CÓDIGO: TSP171R-HUL
No. MAF: 200-1397

MAF

BUJE PARA BARRA
DE TORSIÓN



CÓDIGO: TSP171R-POL
No. MAF: TSP171R

MAF

BUJE PARA BARRA
DE TORSIÓN



CÓDIGO: TSP172R-HUL
No. MAF: 200-1479

MAF

BUJE PARA BARRA
DE TORSIÓN



CÓDIGO: TSP172R-POL
No. MAF: TSP172R

MAF

SOPORTE
GRANADA



CÓDIGO: 2482
No. MAF: 2482

MAF

TORNILLO "U"
1 1/8" x 4 1/16" x 9"

CÓDIGO: U9G090-B
No. MAF: U-9G090-B

MAF

TORNILLO "U"
1 1/8" x 4 1/16" x 10.00"

CÓDIGO: U9G100-B
No. MAF: U-9G100-B

MAF

SOBRECAMA DE
MUELLE KW T -800
PHM 7206



CÓDIGO: TKW0037
No. MAF: TKW0037

MAF

SOPORTE SUP.
P/BRAZO DE T.KW T-800
(OREJAS)



CÓDIGO: TKW0033
No. MAF: TKW0033

MAF

CAMISA PARA
BURRO W-900



CÓDIGO: TKW0007
No. MAF: TKW0007

MAF

FLECHA (BARRA)
1 1/2" x 22"



CÓDIGO: TKW0018
No. MAF: TKW0018

MAF

KENWORTH

KENWORTH SUSPENSIÓN BIG SIX MUELLE KWT912

TUERCA DE COMPRESIÓN
PHM 0030



CÓDIGO: TKW0019
No. MAF: TKW0019

CONTRATUERCA
PHM 0029



CÓDIGO: TKW0020
No. MAF: TKW0020

CONJ. FLECHA
TKW0018, TKW0019,
TKW0020



CÓDIGO: TKW18KIT
No. MAF: TKW18-KIT

RONDANA DE BRONCE



CÓDIGO: TKW0021
No. MAF: TKW0021

BUJE P/TENSÓR KW
BIG SIX, ROCKWELL



CÓDIGO: 20047244
No. MAF: 200-47244

BUJE CENTRAL



CÓDIGO: 1002T
No. MAF: 1002

CHUMACERA
TIPO BIG 6



CÓDIGO: 6198
No. MAF: 6198

MUÑÓN DE APOYO
FUNDICIÓN



CÓDIGO: TKW0006
No. MAF: TKW0006

BUJE P/SUSP.
CENTRAL TIPO VIEJO



CÓDIGO: 1016T
No. MAF: 1016

RONDANA ESCALONADA



CÓDIGO: 9002
No. MAF: 9002

SOPORTE DE ARTICULACIÓN
PHM6198



CÓDIGO: TKW0024
No. MAF: TKW-0024

AGUJA KENWORTH
1 1/2" x 6" C/TUERCAS



CÓDIGO: 6203
No. MAF: 6203

KENWORTH

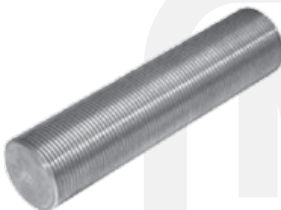
KENWORTH
SUSPENSIÓN BIG SIX
MUELLE KWT912ESPIGA DE MUÑÓN
TKW-800
(USILLO)CÓDIGO: TKW0025
No. MAF: TKW0025

MAF

SOPORTE DE
ARTICULACIÓNCÓDIGO: TKW0009
No. MAF: TKW0009

MAF

**Criterios de Falla Bolsas de aire****Abrasión**

La membrana tiene contacto con otros componentes del vehículo (Ej. Llantas, amortiguadores de impacto) u otros objetos extraños (ej. piedras o vidrios incrustados en el pistón) los cuales friccionan con la membrana y/o el pistón durante la carrera de operación.



KENWORTH

SUSPENSIÓN KENWORTH

TRACTO T600-T800

MUELLE DEL PARABÓLICA 59400

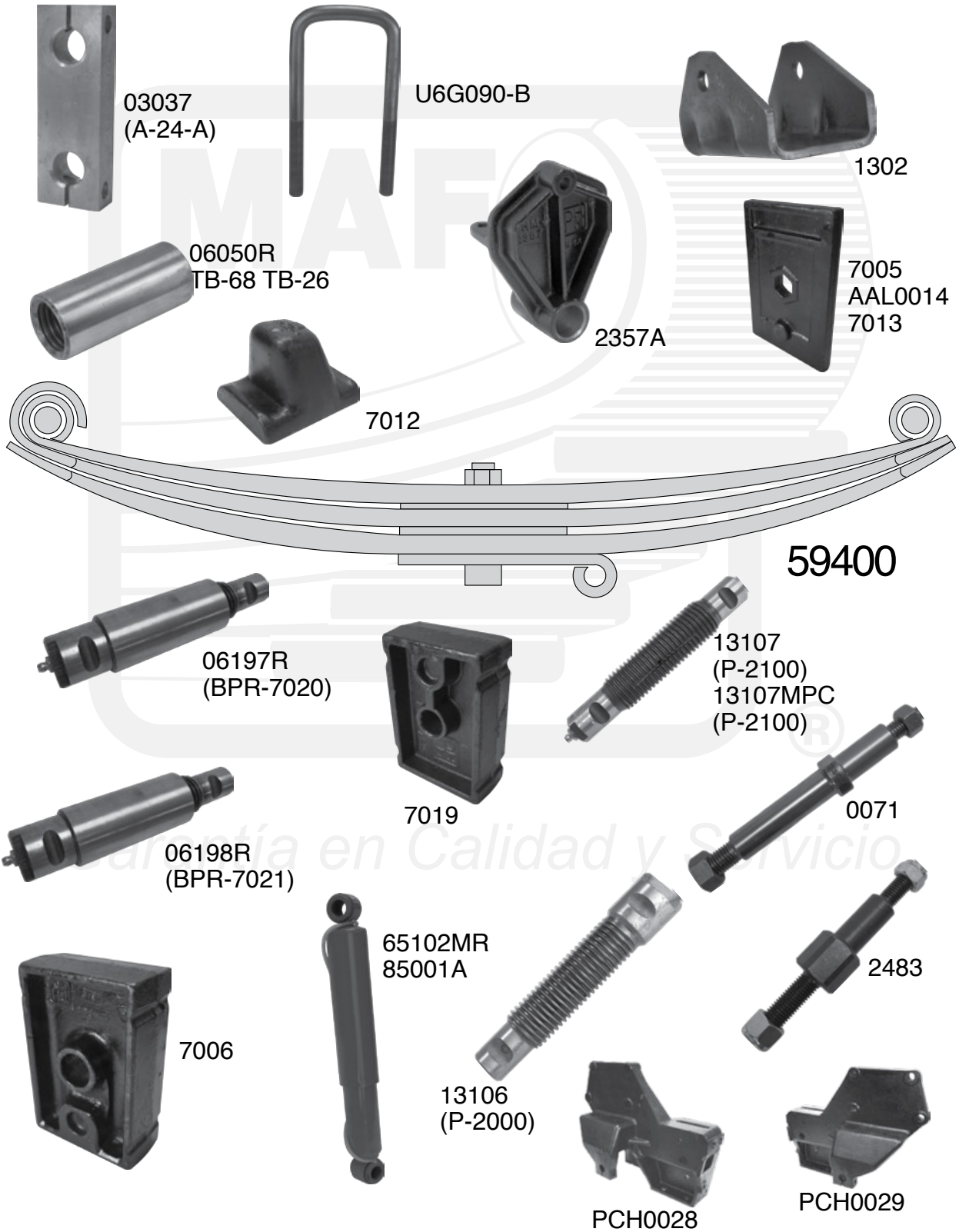

KENWORTH

SUSPENSIÓN KENWORTH TRACTO T600-T800 MUELLE DEL PARABÓLICA 59400

CÓDIGO	No. MAF	DESCRIPCIÓN	CANTIDAD
2483	2483	PERNO SUPERIOR AMORTIGUADOR C/ TUERCAS	2
1302	7-1302	SOPORTE DE AMORTIGUADOR DEL. SUP.	2
AAL0014	AAL0014	(SEPARADOR) JABÓN DE ALUMINIO	2
7005	7005	JABÓN 1/2" x 4.00" x 6.00 IKW K221-4737	2
7006	7006	TACÓN ESPACIADOR 2" x 4" x 6" T-800 K221-4293 FUND.	2
7013	7013	JABÓN 1 1/32"	2
7019	7019	ESPACIADOR KW. DE 2" x 4" x 6" K221-4293	2
0071	0071	PERNO SOPORTE INFERIOR AMORTIGUADOR	2
65102MR	65102	AMORT. MONROE=85001 - 85305- 89410 MERITOR	2
85001A	85001A	AMORTIGUADORES MERITOR	2
06198R	BPR-7021	CTO.PER./BUJE (P-2100/TB-68) BPR7021	2
7012	7012	SOBRE MUELLE DELANTERO .	2
03037	A-24-A	ALBARDÓN	4
13107	P-2100	PERNO ROSCADO	
06050R	TB-68	BUJE ROSCADO TB-26= TB-68	4
06197R	BPR-7020	CTO. PER./BUJE KW T-300/800 (P-2000/TB-68) BPR7020	4
13106	P-2000	PERNO ROSCADO	4
U6G090-B	U-6G090-B	TORNILLO "U" 3/4" x 4 1/16" x 9.00"	4
2357A	2357A	PERCHA DEL TRAS. P/INSERTAR BUJE ROSCADO	2
PCH0028	PCH0028	PERCHA DEL. DEL. IZQ. FUNDICIÓN	2
PCH0029	PCH0029	PERCHA DEL. DEL. DER. FUNDICIÓN	2
59400	59-400	MUELLE PARABÓLICA 4" x 0.815" x 32" x 32" CON	2
		BUJE ROSCADO TB-68	
	KWD-383	BRACKET 4" x .499" x 2 7/8" x 7 1/4"	2

(VER CATALOGO DE MUELLES 2011)

KENWORTH

SUSPENSIÓN KENWORTH

TRACTO T600-T800

MUELLE DEL PARABÓLICA 59400

PERNO SUPERIOR
AMORTIGUADOR CON
TUERCAS



CÓDIGO: 2483
No. MAF: 2483

MAF

SOPORTE DE
AMORTIGUADOR
DEL. SUSPENSOR



CÓDIGO: 1302
No. MAF: 7-1302

MAF

(SEPARADOR)
JABÓN DE ALUMINIO
KW.



CÓDIGO: AAL0014
No. MAF: AAL0014

MAF

JABÓN 1/2" x 4.00" x
6.00" IKW K221- 4737



CÓDIGO: 7005
No. MAF: 7005

MAF

TACÓN ESPACIADOR
2" x 4" x 6" T-800
K221-4293 FUNDICIÓN



CÓDIGO: 7006
No. MAF: 7006

MAF

JABÓN 1 1/32 KW



CÓDIGO: 7013
No. MAF: 7013

MAF

ESPACIADOR KW DE
2" x 4" x 6" K221-4293



CÓDIGO: 7019
No. MAF: 7019

MAF

PERNO SOPORTE
INFERIOR
AMORTIGUADOR



CÓDIGO: 0071
No. MAF: 0071

MAF

AMOR.
MONROE=85001- 85305-
89410 MERITOR



CÓDIGO: 65102MR
No. MAF: 65102

MAF

AMORTIGUADORES
MERITOR



CÓDIGO: 85001A
No. MAF: 85001A

MAF

CONJ. PER./BUJE
(P2100/TB-68)
BPR7021



CÓDIGO: 06198
No. MAF: BPR-7021

MAF

SOBRE MUELLE
DELANTERO
KENWORTH W-900



CÓDIGO: 7012
No. MAF: 7012

MAF

KENWORTH

SUSPENSIÓN KENWORTH TRACTO T600-T800 MUELLE DEL PARABÓLICA 59-400

ALBARDÓN
KENWORTH T-800



CÓDIGO: 03037
No. MAF: A-24-A

MAF

PERNO ROSCADO



CÓDIGO: 13107
No. MAF: P-2100

MAF

TORNILLO "U" 3/4 X 4
1/16" x 2" x 9.00"



CÓDIGO: U6G090-B
No. MAF: U-6G090-B

MAF

BUJE ROSCADO
TB-26= TB-68



CÓDIGO: 0605R
No. MAF: TB-68

MAF

PERCHA DEL. TRAS
P/INSERTAR BUJE
ROSCADO



CÓDIGO: 2357A
No. MAF: 2357A

MAF

PERNO ROSCADO



CÓDIGO: 13106
No. MAF: P-2000

MAF

CONJ. PER./BUJE
(P-200/TB-68)
BPR7020



CÓDIGO: 06197R
No. MAF: BPR-7020

MAF

PERCHA DEL. DEL.
DER. KW T-800 PLACA



CÓDIGO: PCH0028
No. MAF: PCH0028

MAF

PERCHA DEL. DEL. IZQ
KW T-800 PLACA



CÓDIGO: PCH0029
No. MAF: PCH0029

MAF

TACÓN ESPACIADOR
EN LA MUELLE



CÓDIGO: TKW0038
No. MAF: TKW0038

MAF

Calidad y Servicio

**MUELLE DELANTERA
COMPLETA KENWORTH
PARABÓLICA 59464F**

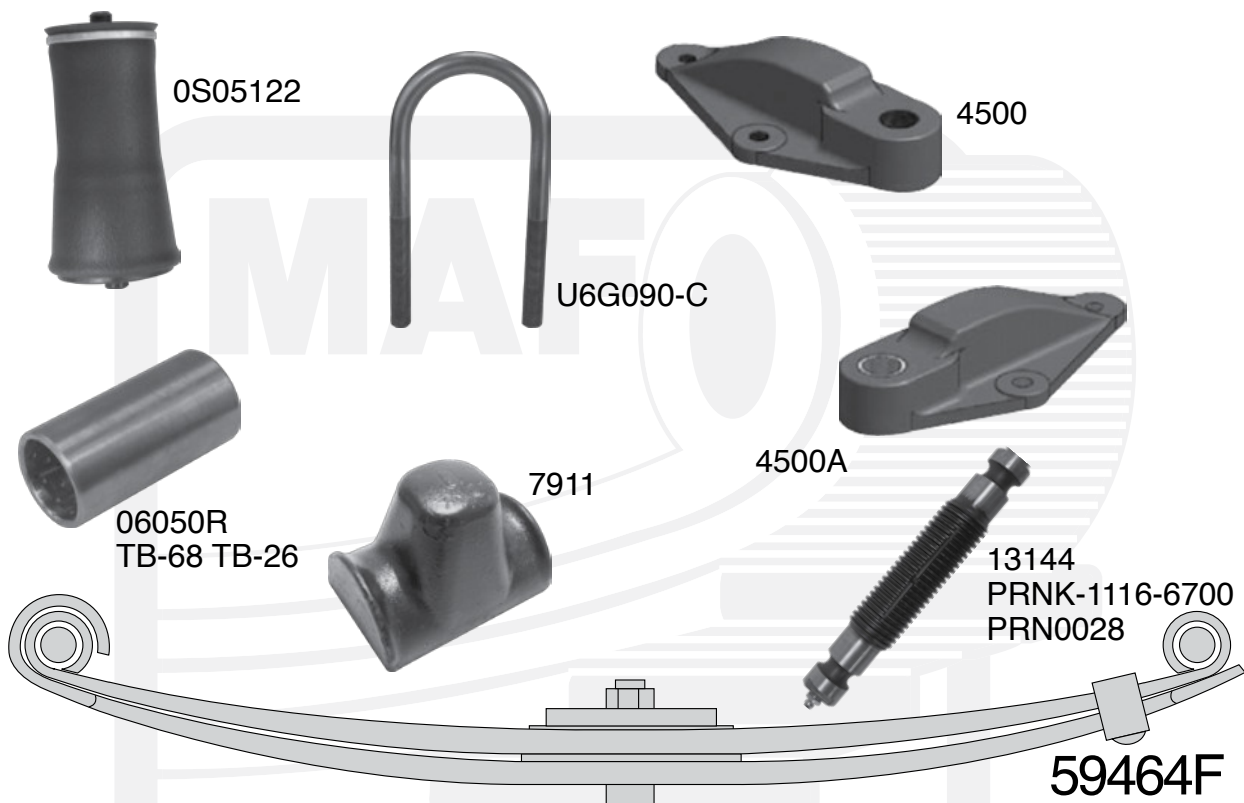

KENWORTH

MUELLE DELANTERA
COMPLETA KENWORTH
PARABÓLICA 59464F

CÓDIGO	No. MAF	DESCRIPCIÓN	CANTIDAD
1S05122	1S5122	BOLSA DE AIRE CABINA KW T-2000	2
4500	4500	PERCHA KENWORTH COLUMPIO T NUEVO 4.00	2
4500A	4500A	PERCHA TRAS. DEL. IZQ-DER. KW BUJE MUELLE 1 3/4"	2
7911	7911	SOBRE MUELLE KW NUEVO	2
65102MR	65102	AMORTIGUADOR MONROE=85001 - 85305- 89410 MERITOR 2	2
0906	1-0906	TACÓN CUÑA DE 4" x 6" ALTO 2 3/8"	2
0907	1-0907	TACÓN CUÑA DE 4" x 6" BAJO 2"	2
06050R	TB-26 = TB-68	BUJE ROSCADO TB-26= TB-68 (ANTES TB-70)	2
06852R	RB-249	KW T-2000, P/MUELLE PA-200-249 #B65-1001 55-964	2
200249	200-249	200-249 BUJE P/MUELLE 1 3/4" x 7" KW T-2000	2
13144	P-2300	P-2300 PERNO ROSC. KW 1 3/8" L 7 13/16" T-300 NUEVO	2
PRN0028	CPRN0028	PERNO ROSCADO C/BUJE KW T-2000 DE 1 3/4" x 7 1/2"	2
U6G090-C	U-6G090-C	TORNILLO "U" 3/4" x 4 1/16" x 9.00"	4
200295	200259	BUJE P/MUELLE 1 3/4" x 7 1/2" KW T-2000	2
PRKR1116-6700	PRKR-1116-6700	PERNO ROSCADO KENWORTH T-2000 RANURADO 6.700"	2
PRKR-1116-7	PRKR-1116-7	PERNO ROSCADO KENWORTH T-2000 RANURADO 7"	2
GND0020	GND-0020	PERNO 1 1/16" KW D=1 3/4" E=7,525 C A C=6,315 TOR 1/2"	2
596464	59-464F	MUELLE PARABÓLICA 4.00" x .999" x 27.00" x 32 3/16"	2

VER CATÁLOGO DE MUELLES MAF 2011

Garantía en Calidad y Servicio

KENWORTH

MUELLE DELANTERA COMPLETA KENWORTH PARABÓLICA 59464F

BOLSA DE AIRE CABINA
KW T-2000



CÓDIGO: 1S05122
No. MAF: 1S05122

MAF

4500 PERCHA
KENWORTH
COLUMPIO T NUEVO



CÓDIGO: 4500
No. MAF: 4500

MAF

4500A PERCHA TRAS
DEL. IZQ-DER KW BUJE
MUELLE 1 3/4"



CÓDIGO: 4500A
No. MAF: 4500A

MAF

SOBRE MUELLE KW
NUEVO



CÓDIGO: 7911
No. MAF: 7911

MAF

65102 AMORT.
MONROE=85001 -
85305- 89410 MERITOR



CÓDIGO: 65102MR
No. MAF: 65102

MAF

TACÓN CUÑA DE 4" x 6"
ALTO 2 3/8"



CÓDIGO: 0906
No. MAF: 1-0906

MAF

TACÓN CUÑA DE 4" x 6"
BAJO 2



CÓDIGO: 0907
No. MAF: 1-0907

MAF

PBUJE ROSCADO
TB-26= TB-68
(ANTES TB-70)



CÓDIGO: 06050R
No. MAF: TB-26=TB-68

MAF

KW T-200, P/MUELLE
PA-200-249 #B65-1001
55-964



CÓDIGO: 06852R
No. MAF: RB-249

MAF

200-249 BUJE P/
MUELLE 1 3/4" x 7" KW
T-2000



CÓDIGO: 200249
No. MAF: 200-249

MAF

PERNO ROSCADO
C/BUJE KW T-2000 DE
1 3/4" x 7 1/2"



CÓDIGO: PRN0028
No. MAF: CPRN0028

MAF

PERNO ROSCADO
C/BUJE KW T-2000 DE
1 3/8" x 7 13/16" x 9.00"



CÓDIGO: 13144
No. MAF: P-2300

MAF

KENWORTH

MUELLE DELANTERA
COMPLETA KENWORTH
PARABÓLICA 59464F

TORNILLO "U"
3/4" x 4 1/16" x 9.00"



CÓDIGO: U6G090-C
No. MAF: U-6G090-C

MAF

PERNO 1 1/16 KW D=1
3/4 E=7,525 CA C=6,315
TOR .1/2



CÓDIGO: GND0020
No. MAF: GND0020

MAF

PERNO ROSCADO
KENTWORTH T-2000
RANURADO 6.700



CÓDIGO: PRKR1116-
6700

No. MAF: PRKR1116-
6700

MAF

PERNO ROSCADO
KENTWORTH
RANURADO 7"



CÓDIGO: PRKR-116-7
No. MAF: PRKR-116-7

MAF

BUJE P/MUELLE
1 3/4 x 7 1/2" KW T-2000



CÓDIGO: 200295
No. MAF: 200-295

MAF

Garantía en Calidad y Servicio

KENWORTH

KENWORTH SUSPENSIÓN TRACTOR 4 MUELLE REYCO TORTON TANDEM KWT200

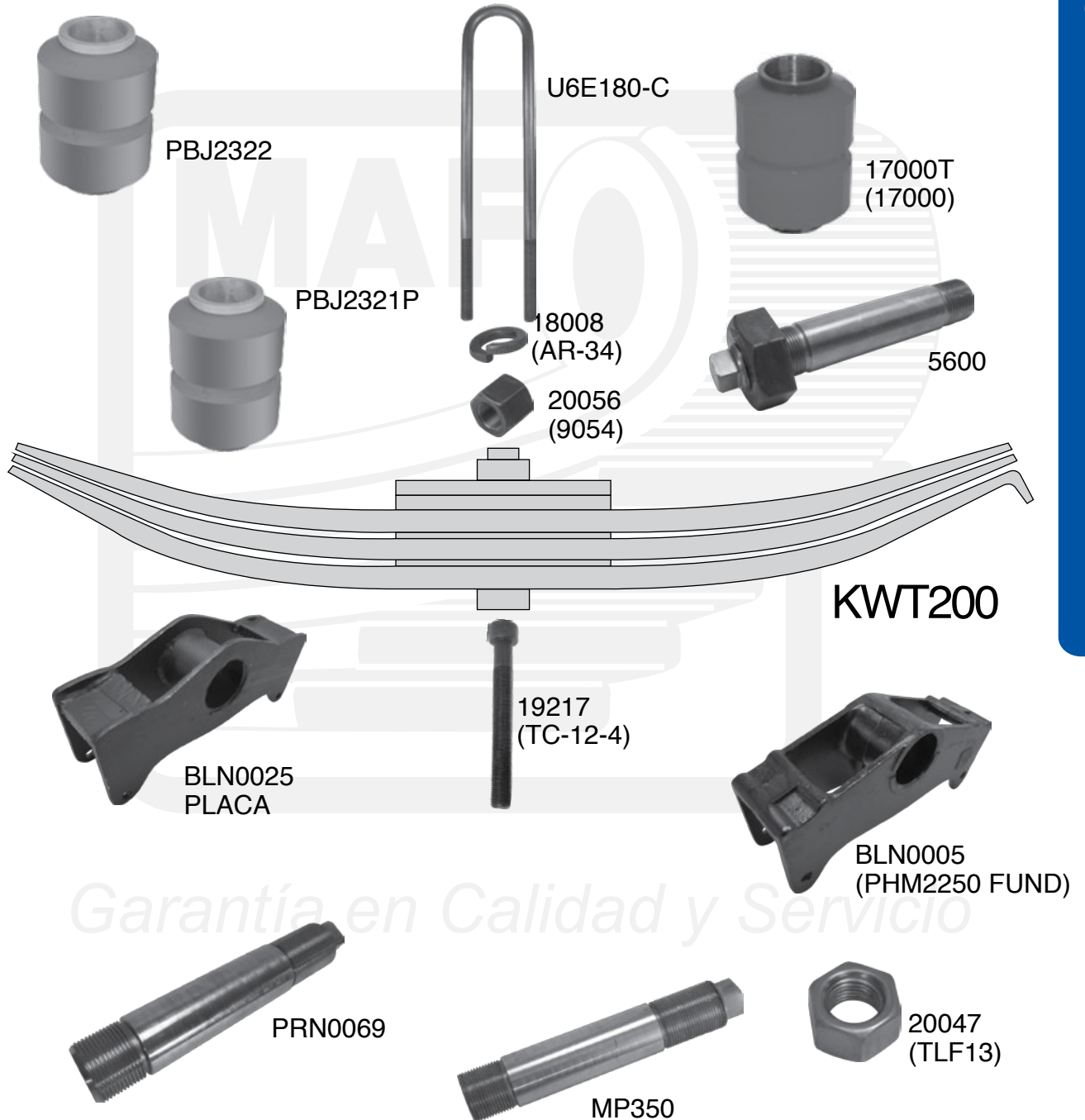

KENWORTH

KENWORTH SUSPENSIÓN
TRACTOR 4 MUELLE
REYCO TORTON TANDEM KWT200

CÓDIGO	No. MAF	DESCRIPCIÓN	CANTIDAD
BLN0005	BLN0005	BALANCÍN P/SUSPENSIÓN PHM 2250	2
BLN0025	BLN0025	BALANCÍN P/SUSPENSIÓN (PLACA)	2
17000T	17000	BUJE PARA BALANCÍN	2
5600	5600	PERNO PARA TORRE CENTRAL TIPO 1 1/2"	2
MP350	MP-350	PERNO TENSOR SIN TUERCA	2
PRN0069	PRN0069	PERNO BALANCÍN	2
PBJ2321P	PBJ2321P	BUJE CENTRAL P/BALANCÍN 1 1/2" POL.	2
PBJ2322	PBJ2322	BUJE CENT. PARA BALANCÍN 1 1/2" RANURADO	2
20047	TLF13	TUERCA FINA DE 1/2" °2	2
19217	TC-12-4	TORNILLO DE CENTRO 1/2" x 4.00" °8	2
U6E180-C	U-6E180-C	TORNILLO "U" 3/4" x 3 1/16" x 18.00"	4
18008	AR-34	RONDANA DE PRESIÓN 3/4" P/REFACCIÓN	8
20056	9054	TUERCA FINA ALTA DE 3/4" 9054 °8	8
KWT200	KWT200	MUELLE COMPLETA 3 HOJAS 3" x .788" x 23" x 24"	2

VER CATÁLOGO DE MUELLES MAF 2011



Garantía en Calidad y Servicio

KENWORTH

KENWORTH SUSPENSIÓN TRACTOR 4 MUELLE REYCO TORTON TANDEM KWT200

**BALANCÍN
FUNDICIÓN**



CÓDIGO: BLN0005
No. MAF: BLN0005

MAF

**BALANCÍN
PLACA**



CÓDIGO: BLN0025
No. MAF: BLN0025

MAF

**BUJE
POLIURETANO**



CÓDIGO: 17000T
No. MAF: 1700

MAF

**PERNO
CENTRAL**



CÓDIGO: 5600
No. MAF: 5600

MAF

**PERNO TENSOR SIN
TUERCA**



CÓDIGO: MP350
No. MAF: MP-350

MAF

**PERNO
BALANCÍN**



CÓDIGO: PRN0069
No. MAF: PRN0069

MAF

**BUJE CENTRAL
1 1/2"**



CÓDIGO: PBJ2321P
No. MAF: PBJ2321P

MAF

**BUJE CENTRAL
1 1/2" RANURADO**



CÓDIGO: PBJ2322
No. MAF: PBJ2322

MAF

**TUERCA FINA
1/2" 02**



CÓDIGO: 20047
No. MAF: TLF13

MAF

**TORNILLO CENTRO
1/2" x 4" 08**



CÓDIGO: 19217
No. MAF: TC-12-4

MAF

**TORNILLO "U"
3/4" x 3 1/16" x 18.00**



CÓDIGO: U6E180-C
No. MAF: U-6E180-C

MAF

**TUERCA FINA ALTA
3/4" 08**



CÓDIGO: 20056
No. MAF: 9054

MAF

KENWORTH

KENWORTH SUSPENSIÓN
TRACTOR 4 MUELLE
REYCO TORTON TANDEM KWT200RONDANA DE
PRESIÓN 3/4"CÓDIGO: 18008
No. MAF: AR-34

MAF

**Crterios de Falla Bolsas de aire**

Abrasión



KENWORTH

KENWORTH T300 -T450 MUELLE KWD300

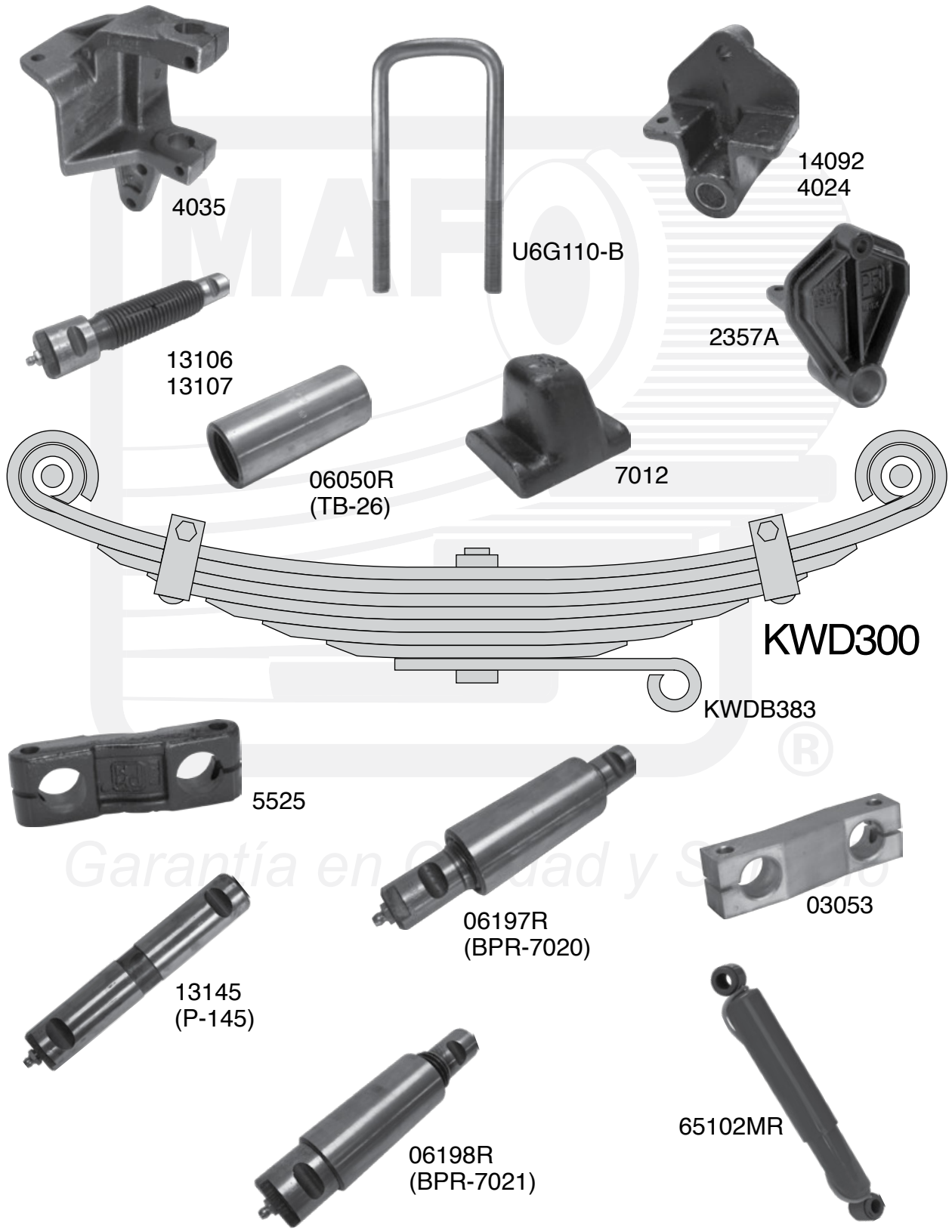

Garantía en Calidad y Servicio

KENWORTH

KENWORTH T300 -T450
MUELLE KWD300

CÓDIGO	No. MAF	DESCRIPCIÓN	CANTIDAD
4035	4035	4035 PERCHA DELANTERA KW T-300	2
65102MR	65102	AMORTIGUADOR MONROE=85001 - 85305- 89410 MERITOR	2
06050R	TB-26=TB-68	BUJE ROSCADO TB-26= TB-68 (ANTES TB-70)	2
13106	13106	P-2000 PERNO KENWORTH (# M.POWER MP-2001)	2
13107	13107	P-2100 PERNO KENWORTH (# M.POWER MP-2101)	2
14092	4024	PERCHA COLUMPIO	2
06197R	BPR-7020	CTO. PER./BUJE KW T-300/800 (P-2000/TB-68) BPR7020	2
06198R	BPR-7021	CTO.PER./BUJE DINA 661-861 (P-2100/TB-68) BPR7021	2
2357A	2357A	PERCHA DEL TRAS KW T-800 P/INSERTAR BUJE ROSCADO	2
13145	P-145	P-145 P. LISO 145 KW P/ALBARDÓN 5525 1 1/4" X 6 13/16"	2
03053	A-40-A	ALBARDÓN ALUMINIO	4
5525	5525	ALBARDÓN KW FUNDICIÓN PARA PERNO DE 1 1/4"	4
7012	7012	SOBRE MUELLE DELANTERO KENWORTH W-900	2
U6G110-B	U-6G110-B	TORNILLO "U" 3/4" x 4 1/16" x 11.00"	4
KWDB383	KWD3383	SOPORTE DE AMORTIGUADOR	2
KWD300	KWD-300	MUELLE DE 7 HOJAS	
		HOJA 01 4" x 401" x 26 1/4" x 26 1/4"	

VER CATÁLOGO DE MUELLES MAF 2011

Garantía en Calidad y Servicio

KENWORTH

KENWORTH T300 -T450 MUELLE KWD300

AMORTIGUADOR
MONROE = 85001 -
85305 - 89410 MERITOR



CÓDIGO: 65102MR
No. MAF: 65102

SOBRE MUELLE
DELANTERO W-900



CÓDIGO: 7012
No. MAF: 7012

P-2000 PERNO
KENTWORTH (#M.
POWER MP-2001)



CÓDIGO: 13106
No. MAF: 13106

P-2100 PERNO
KENTWORTH (#M.
POWER MP-2101)



CÓDIGO: 13107
No. MAF: 13107

ALBARDÓN KW FUND.
P/PERNO 1 1/4"



CÓDIGO: 5525
No. MAF: 5525

PERCHA DEL. TRAS.
KW T-800 P/INSERTAR
BUJE ROSCADO



CÓDIGO: 2357A
No. MAF: 2357A

PERCHA DELANTERA
KW T-300



CÓDIGO: 4035
No. MAF: 4035

BUJE ROSCADO
TB-26 = TB-68
(ANTES TB-70)



CÓDIGO: 06050R
No. MAF: TB-26 = TB-68

TORNILLO "U"
3/4" x 4 1/16" x 11.00"



CÓDIGO: U6B110-B
No. MAF: U-6B110-B

CTO. PER/BUJE KW
T-300/800 (P-2000/TB-68)
BRP7020



CÓDIGO: 06197R
No. MAF: BPR-7020

P-145 LISO 145
KW P/ALBARDÓN
5525 1 1/4" x 6 16/16"



CÓDIGO: 13145
No. MAF: P-145

PERCHA COLUMPIO
PHM



CÓDIGO: 14092
No. MAF: 4024

KENWORTH

KENWORTH T300 -T450
MUELLE KWD300

CTO. PER./BUJE DINA
661-361 (P-2100 / TB-68)
BPR7021



CÓDIGO: 06198R
No. MAF: BPR-7021

MAF

ALBARDÓN
ALUMINIO

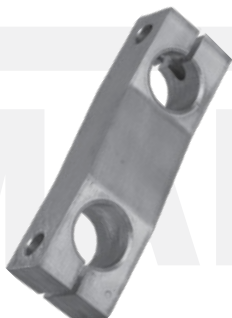

CÓDIGO: 03053
No. MAF: A-40-A

MAF



Criterios de Falla Bolsas de aire

Sobrecarga

Cuando un vehículo es sobrecargado la válvula de nivel de altura va a abrir para ajustar la altura del vehículo subiendo la presión dentro de la bolsa de aire al máximo de la presión disponible del sistema. El uso inadecuado de la bolsa de aire fuera del rango de presión recomendable podría causar daño a las bolsas, pistones y/o platos.

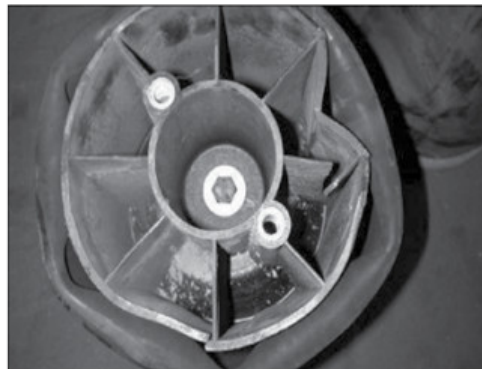

MERCEDES BENZ
CAMIÓN CHASIS
CAMIÓN URBANO 1218L
MUELLE MBD1218L

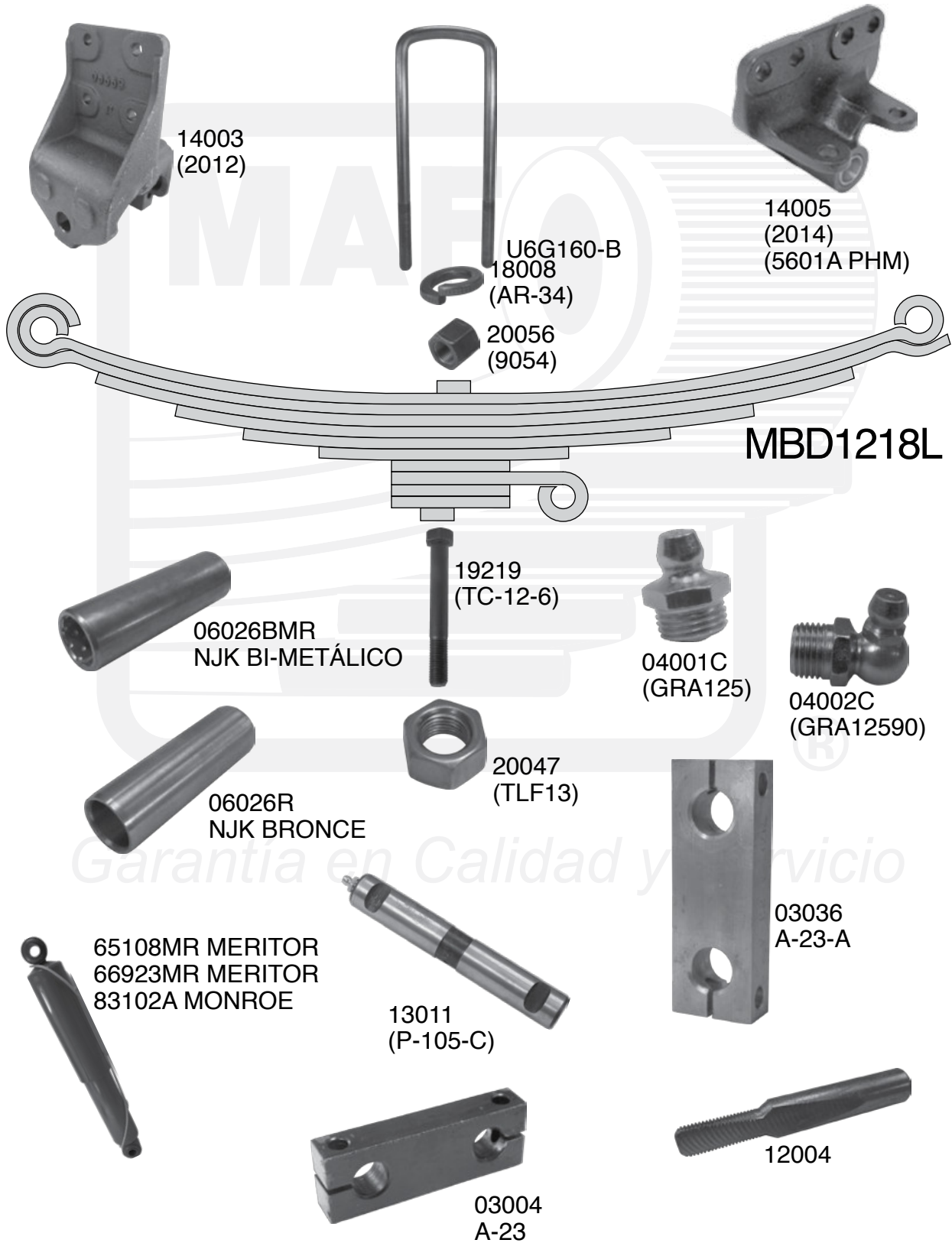

Garantía en Calidad y Servicio

MERCEDES BENZ

CAMIÓN CHASIS CAMIÓN URBANO 1218L MUELLE MBD1218L

CÓDIGO	No. MAF	DESCRIPCIÓN	CANTIDAD
14005	2014=5601-A	PERCHA DEL.TRA.M.BENZ 91-05 P/LARGA PER1"FUNDD	2
14003	2012	PERCHA IMO 5600 PHM 5001 FUNDICIÓN	2
12004	PA151	PERNO PASADOR	8
03004	A-23	ALBARDÓN ÁGUILA	4
03036	A-23-A	ALBARDÓN ÁGUILA	4
06026BMR	NJK BI-METALICO	BUJE BI-METÁLICO 1 1/4" x 1.010" x 4.00" NJK	4
06026R	NJK 254-1	BUJE BRONCE 1 1/4" x 1.00" x 4.00" NJK 254-1	4
13011R	P-105-CR	PERNO FAMSA P-105-C=PRN0014 P/SEG.REDONDO	4
04001C	GRA125	GRASERA RECTA NPT 1/8"	4
04002C	GRA12590	GRASERA DE 1/8" NPT 90°	4
65108MR	65108	AMORTIGUADOR MONROE = 85030 - 89940 MERITOR	2
66923MR	66923	AMORTIGUADOR MONROE = 83102 MERITOR	2
83102A	83102	AMORTIGUADOR MERITOR = 66923 MONROE	2
U6G160-B	U6G160-B	TORNILLO "U" 3/4" x 4 1/16" x 16.00"	4
20056	9054	TUERCA FINA ALTA 3/4" °8	8
18008	AR-34	RONDANA DE PRESIÓN 3/4"	8
20047	TLF13	TUERCA UNF DE 1/2" °2	1
19219	TC-12-6	TORNILLO DE CENTRO 1/2" x 6.00"	1
MBD1218L	MBD-1218L	MUELLE DE 10 HOJAS	2
		HOJA 01 4" x .447" x 28" x 33 1/2"	

Garantía de Servicio
VER CATÁLOGO DE MUELLES MAF 2011

MERCEDES BENZ
 CAMIÓN CHASIS
 CAMIÓN URBANO 1218L
 MUELLE MBD1218L

PERCHA DEL. TRAS.
 PERNO 1"



CÓDIGO: 14005
 No. MAF: 2014

PERCHA FAMSA
 DEL. DEL. PERNO 1"



CÓDIGO: 14003
 No. MAF: 2012

PERNO 1" X 6 5/8"
 SEGURO CUADRADO



CÓDIGO: 13011
 No. MAF: P-105-C

BUJE-BIMETÁLICO
 1 1/4" x 1.010" x 4.00"



CÓDIGO: 06026BMR
 No. MAF: NJK

BUJE BRONCE
 1 1/4" x 1.00" x 4.00"



CÓDIGO: 06026R
 No. MAF: NJK254-1

PERNO 1" X 6 5/8"
 SEGURO REDONDO



CÓDIGO: 13011R
 No. MAF: P-105-CR

GRASERA RECTA
 NTP 1/8"



CÓDIGO: 04001C
 No. MAF: GRA 125

GRASERA DE 1/8"
 NTP 90°



CÓDIGO: 04002C
 No. MAF: GRA 12590

AMORTIGUADOR
 MERITOR



CÓDIGO: 65108MR
 No. MAF: 65108

AMORTIGUADOR
 MONROE = 83102
 MERITOR



CÓDIGO: 66923MR
 No. MAF: 66923

AMORTIGUADOR
 MONROE = 66923
 MERITOR



CÓDIGO: 8310A
 No. MAF: 83102

TORNILLO "U"
 3/4" x 4 1/16" x 16.00"



CÓDIGO: U6G160-B
 No. MAF: U6G160-B

MERCEDES BENZ

CAMIÓN CHASIS CAMIÓN URBANO 1218L MUELLE MBD1218L

TUERCA FINA ALTA
3/4" 08



CÓDIGO: 20056
No. MAF: 9054

MAF

RONDANA DE
PRESIÓN 3/4"



CÓDIGO: 18008
No. MAF: AR-34

MAF

TORNILLO CENTRO
1/2" x 5.00"



CÓDIGO: 19218
No. MAF: TC-12-5

MAF

TUERCA UNF
08 DE 1/2"



CÓDIGO: 20047
No. MAF: TLF3

MAF

ALBARDÓN ÁGUILA



CÓDIGO: 03004
No. MAF: A-23

MAF

ALBARDÓN ÁGUILA



CÓDIGO: 03036
No. MAF: A-23-A

MAF

PERNO CON MUESCA



CÓDIGO: 12004
No. MAF: PA151

MAF

Garantía en Calidad y Servicio

MERCEDES BENZ
CAMIÓN CHASIS
CAMIÓN URBANO 1218L
MUELLE MBT1218L

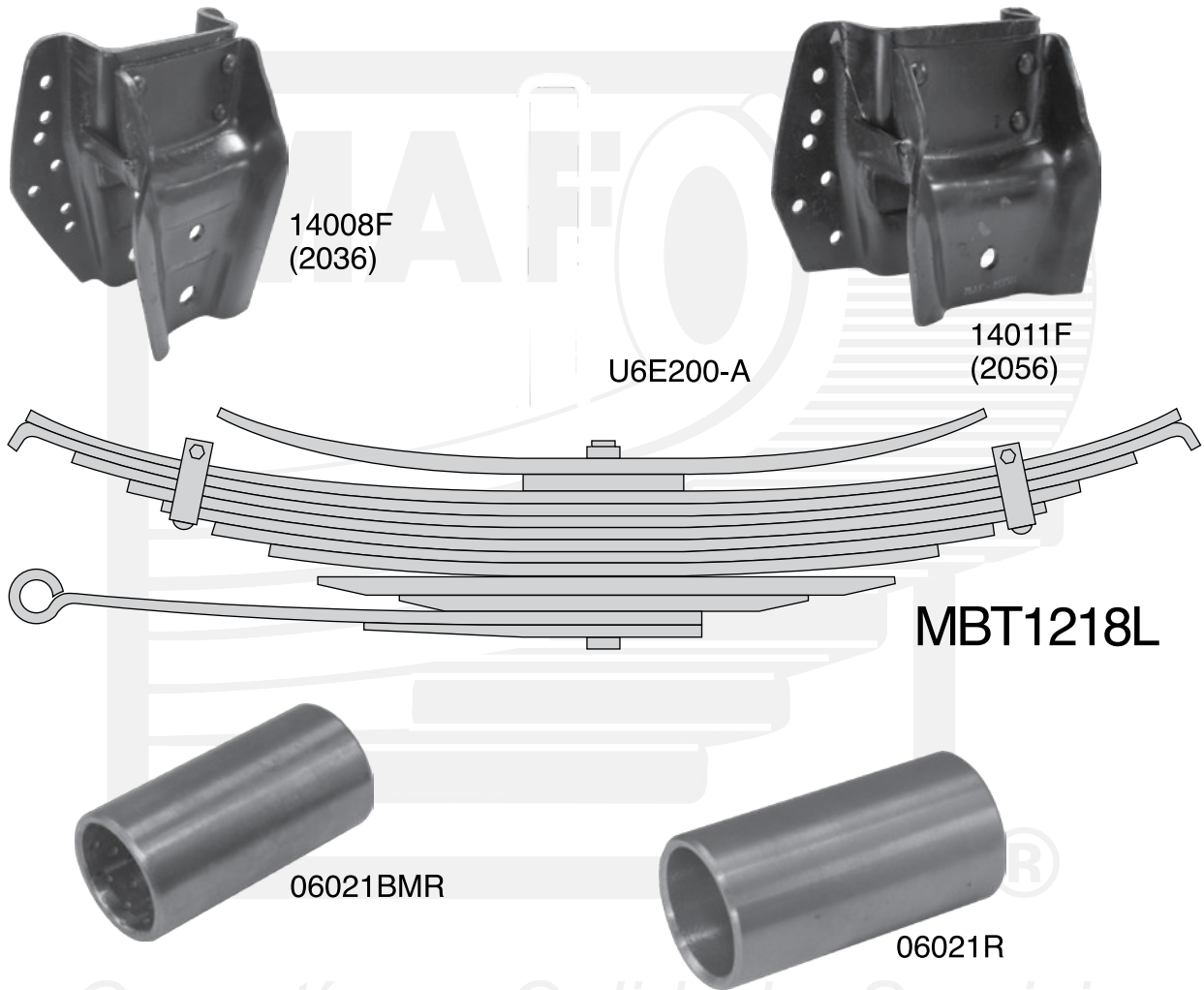

Garantía en Calidad y Servicio

MERCEDES BENZ

CAMIÓN CHASIS CAMIÓN URBANO 1218L MUELLE MBT1218L

CÓDIGO	No. MAF	DESCRIPCIÓN	CANTIDAD
14008F	2036	PERCHA M.B. FAMSA S1900,2500 F-1314	2
14011F	2056	PERCHA M.B. FAMSA S1900,2500,F1314	2
U6E200-A	U-6E200-A	TORNILLO "U" 3/4" x 3 1/16" x 20.00"	4
06021BMR	BUJE BI-METALICO	BUJE BI-METÁLICO 1 1/2" x 1.260" x 3.00"	1
06021R	RNG	BUJE BRONCE 1 1/2" x 1 1/4" x 3.00"	1
MBT1218L	MBT-1218L	MUELLE DE 13 HOJAS CON GUÍA	2
		HOJA 01 3" x .625" x 39" x 39"	

VER CATÁLOGO DE MUELLES MAF 2011



Criterios de Falla Bolsas de aire

Contaminación

La membrana de las bolsa de aire no es resistente a solventes, aceites hidráulicos ni lubricantes.

El contacto permanente con productos químicos va a causar fallas prematuras a las bolsas de aire.

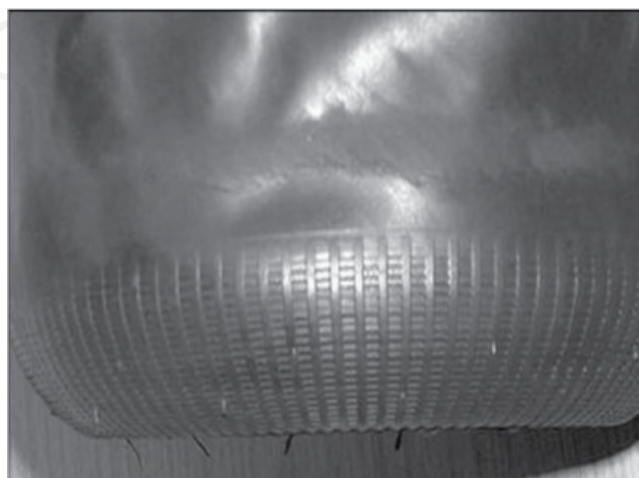

MERCEDES BENZ

CAMIÓN CHASIS

CAMIÓN URBANO 1218L

MUELLE MBT1218L

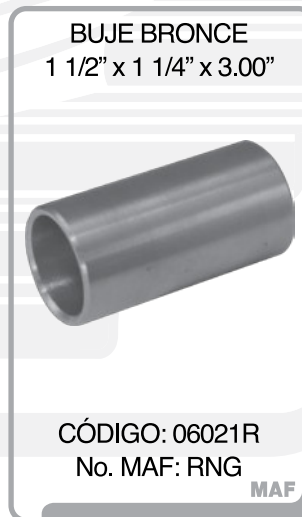
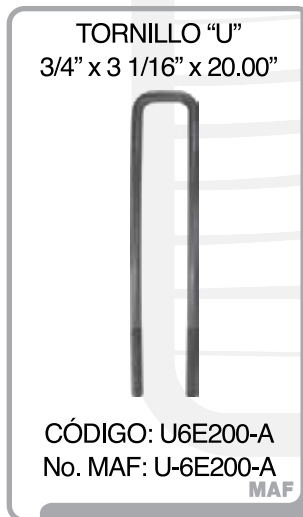

Garantía en Calidad y Servicio

NISSAN

ESTAQUITAS Y PICK UP
NISSAN DTS6094M

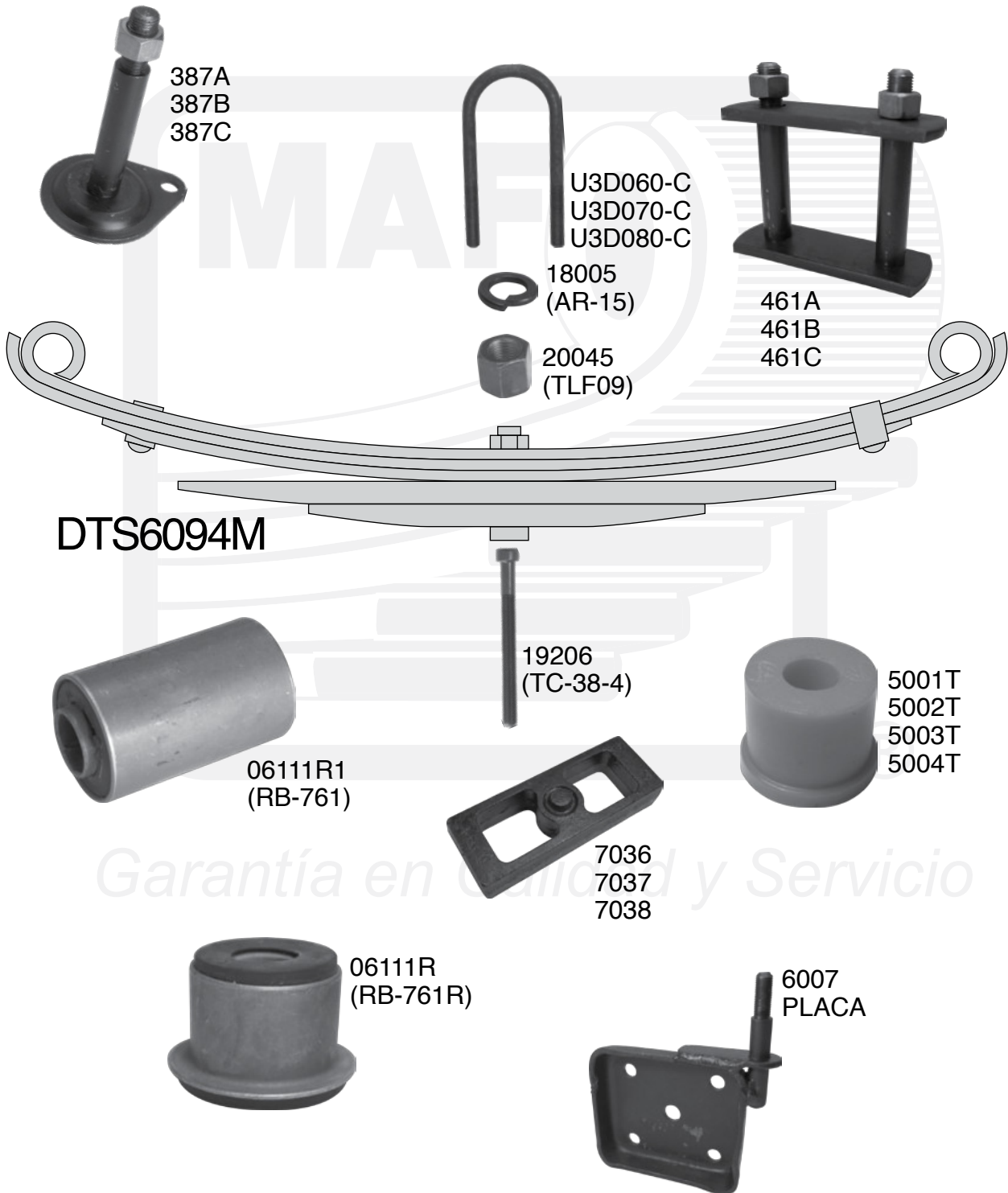

Garantía en Calidad y Servicio

ESTAQUITAS Y PICK UP NISSAN DTS6094M

CÓDIGO	No. MAF	DESCRIPCIÓN	CANTIDAD
06111R	RB-761R	BUJE FIERRO Y HULE (2 PZS.) 18.5 mm CORTO	4
06111R1	RB-761	BUJE FIERRO Y HULE (1 PZ.) 18.5 mm) LARGO	2
U3D060-C	U-3D060-C	TORNILLO "U" 1/2" x 2 9/16" x 6.00"	4
U3D070-C	U-3D070-C	TORNILLO "U" 1/2" x 2 9/16" x 7.00"	4
U3D080-C	U-3D080-C	TORNILLO "U" 1/2" x 2 9/16" x 8.00"	4
20053	9051	TUERCA FINA ALTA DE 1/2" ø8	8
18005	AR-12	RONDANA DE PRESIÓN 1/2"	8
461A	461-A	COLUMPIO PERNO 5/8"	2
461B	461-B	COLUMPIO PERNO 3/4"	2
461C	461-C	COLUMPIO PERNO 25/32" 20mm	2
6007	6007	TAPA SOPORTE DE AMORTIGUADOR FUNDICIÓN	2
6007PLACA	6007PLACA	TAPA SOPORTE DE AMORTIGUADOR PLACA	2
387A	387-A	PERNO PARTE FIJA DE 5/8"	2
387B	387-B	PERNO PARTE FIJA DE 3/4"	2
387C	387-C	PERNO PARTE FIJA DE 18mm	4
5001T	5001	BUJE PARA MUELLE INTERIOR 5/8"	4
5002T	5002	BUJE NISSAN	4
5003T	5003	BUJE PARA MUELLE 3/4"	4
5004T	5004	BUJE PARA MUELLE 5/8"	4
7036	7036	SEPARADOR DE 1.00" x 2 1/4" x 4 5/8"	2
7037	7037	SEPARADOR DE 1 1/2" x 2 1/4" x 4 5/8"	2
7038	7038	SEPARADOR DE 2.00" x 2 1/4" x 4 5/8"	2
19206	TC-38-4	TORNILLO DE CENTRO 3/8" x 4.00"	2
20045	TLF09	TUERCA HEX. LIVIANA FINA DE 3/8" ø2	2
DTS6094M	DTS-6094M	MUELLE 4 HOJAS 23 3/4" x 23 3/4"	2
		HOJA 1RA 2 1/4" x .323" x 23 3/4" x 23 3/4"	
		HOJAS DE REBOTE EN .625" DE ESPESOR	

VER CATÁLOGO DE MUELLES 2011

NISSAN

ESTAQUITAS Y PICK UP NISSAN DTS6094M

BUJE HIERRO Y HULE
CORTO 18.5mm



CÓDIGO: 06111R
No. MAF: RB-761R

MAF

BUJE HIERRO Y HULE
LARGO 18.5mm



CÓDIGO: 06111R1
No. MAF: RB-761

MAF

TORNILLO "U"
1/2" x 2 9/16" x 6.00"



CÓDIGO: U3D060-C
No. MAF: U-3D060-C

MAF

TORNILLO "U"
1/2" x 2 9/16" x 7.00"



CÓDIGO: U3D070-C
No. MAF: U-3D070-C

MAF

TORNILLO "U"
1/2" x 2 9/16" x 8.00"



CÓDIGO: U3D080-C
No. MAF: U-3D00-C

MAF

TUERCA FINA ALTA
1/2" 98



CÓDIGO: 20053
No. MAF: 9051

MAF

RONDANA DE
PRESIÓN 1/2"



CÓDIGO: 18005
No. MAF: AR-12

MAF

COLUMPIO
PERNO 5/8"



CÓDIGO: 461A
No. MAF: 461-A

MAF

COLUMPIO
PERNO 3/4"



CÓDIGO: 461B
No. MAF: 461-B

MAF

COLUMPIO
PERNO 25/32" 20mm



CÓDIGO: 461C
No. MAF: 461-C

MAF

TAPA SOPORTE
AMORT. FUND.



CÓDIGO: 6007
No. MAF: 6007

MAF

TAPA SOPORTE
AMORT. PLACA



CÓDIGO: 6007PLACA
No. MAF: 6007PLACA

MAF

NISSAN

ESTAQUITAS Y PICK UP NISSAN DTS6094M

PERNO PARTE
FIJA 5/8"



CÓDIGO: 387A
No. MAF: 387-A

PERNO PARTE
FIJA 3/4"



CÓDIGO: 387B
No. MAF: 387-B

PERNO PARTE
FIJA 18mm



CÓDIGO: 387C
No. MAF: 387-C

BUJE P/MUELLE
INTERIOR 5/8"



CÓDIGO: 5001T
No. MAF: 5001

BUJE NISSAN



CÓDIGO: 5002T
No. MAF: 5002

BUJE P/MUELLE 3/4"



CÓDIGO: 5003T
No. MAF: 5003

BUJE P/MUELLE
5/8"



CÓDIGO: 5004T
No. MAF: 5004

SEPARADOR DE
2.00" x 2 1/4" x 4 5/8"
FUNDICIÓN



CÓDIGO: 7038
No. MAF: 7038

SEPARADOR DE
1.00" x 2 1/4" x 4 5/8"
FUNDICIÓN



CÓDIGO: 7036
No. MAF: 7036

SEPARADOR DE
1 1/2" x 2 1/4" x 4 5/8"
FUNDICIÓN



CÓDIGO: 7037
No. MAF: 7037

TORNILLO CENTRO
3/8" x 4.00"



CÓDIGO: 19206C
No. MAF: TC-38-4

TUERCA HEX.
LIVIANA FINA 3/8" 02



CÓDIGO: 20045
No. MAF: TLF09

REMOLQUES

QTR218 (3,500 LBS.), QTR224 (4,800 LBS.),
QTR352 (5,800 LBS.), QTR352R (5,800 LBS).
POR EJE.

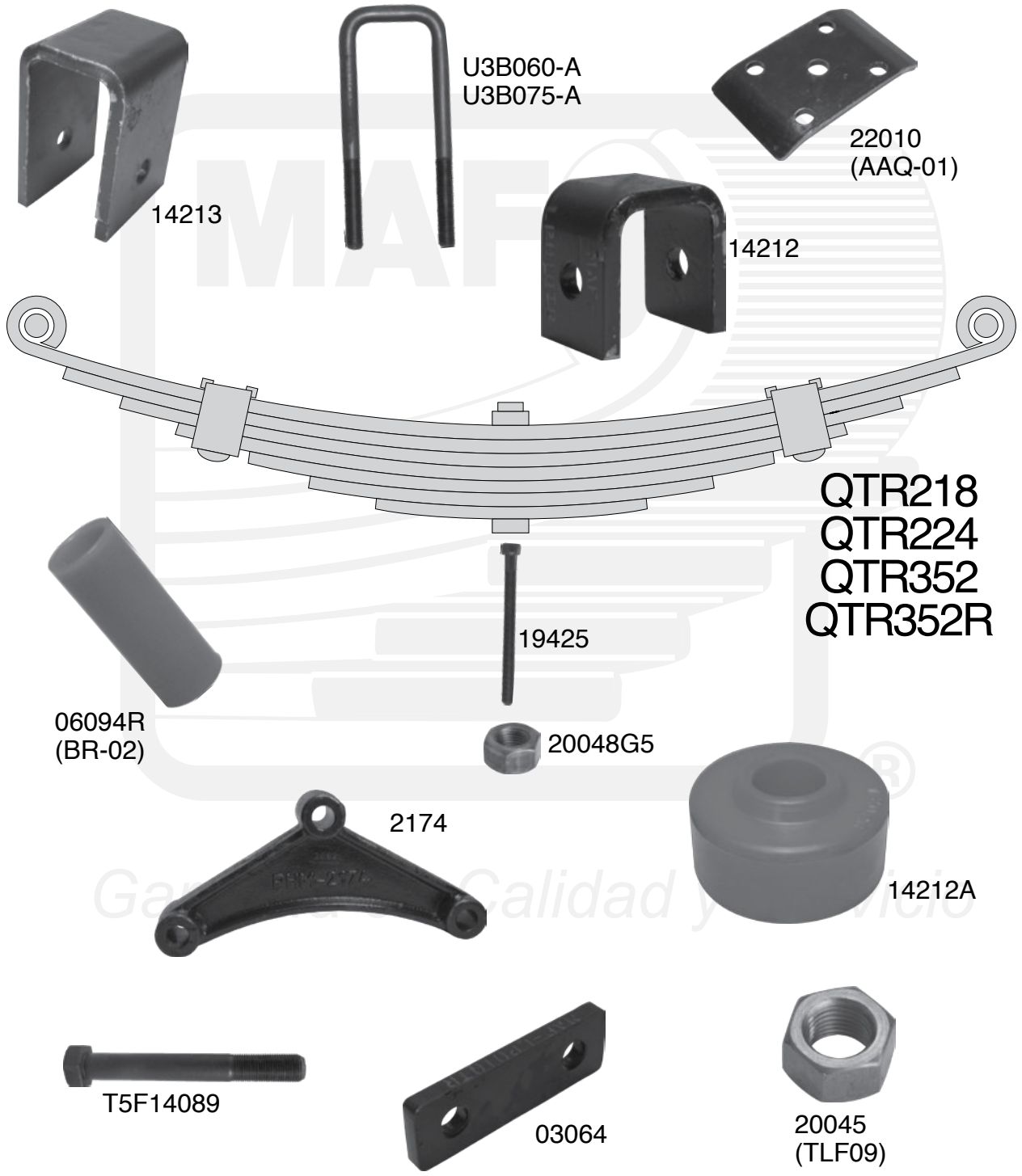

REMOLQUES

QTR218 (3,500 LBS.), QTR224 (4,800 LBS.),
QTR352 (5,800 LBS.), QTR352R (5,800 LBS).
POR EJE.

CÓDIGO	No. MAF	DESCRIPCIÓN	CANTIDAD
2174	2174	BALANCÍN 3 BARRENOS	2
03064	03064	ALBARDÓN .375" x 1 1/2" C/PERF. 9/16"	4
14212	14212	PERCHA LP01 QTR	2
20048G5	20048G5	TUERCA LIVIANA FINA 9/16" °5	4
T5F14089	T5F14089	TORNILLO °5 9/16" x 3 1/2"	4
22010	AAQ-01	ASIENTO DE ABRAZADERA	4
06094R	BN-02	BUJE DE NYLON 11/16" x 9/16" x 1 3/4"	2
U3B060-A	U-3B060-A	TORNILLO "U" 1/2" x 2 1/16" x 6.00"	4
U3B075-A	U-3B075-A	TORNILLO "U" 1/2" x 2 1/16" x 7 1/2"	4
19425	19425	TORNILLO DE CENTRO 3/8" x 2 3/4" x 9/16" x 5/16"	4
20045	TLF09	TUERCA FINA 3/8" °8 °2	8
14213	14213	PERCHA CP01QTR	2
14212A	14212A	CONJUNTO PERCHA S/ALBARDONES	2
QTR218	QTR-218	MUELLE COMPLETA 3 HOJAS	2
		HOJA 1RA 13/4" x .360" x 135/32" x 135/32"	
QTR224	QTR-224	MUELLE COMPLETA 4 HOJAS	2
		HOJA 1RA 1 3/4" x .360" x 13 5/32" x 13 5/32"	
QTR352	QTR-352	MUELLE COMPLETA 5 HOJAS	2
		HOJA 1RA 1 3/4" x .360" x 13 5/32" x 13 5/32"	
QTR352R	QTR-352R	MUELLE COMPLETA 6 HOJAS	4
		HOJA 1RA 1 3/4" x .360" x 13 5/32" x 13 5/32"	
		CON UNA HOJA DE REFUERZO	

VER CATÁLOGO DE MUELLES MAF 2011

REMOLQUES

QTR218 (3,500 LBS.), QTR224 (4,800 LBS.),
QTR352 (5,800 LBS.), QTR352R (5,800 LBS.).
POR EJE.

BALANCÍN 3
BARRENOS



CÓDIGO: 2174
No. MAF: 2174

MAF

ALBARDÓN
LP04QTR



CÓDIGO: 03064
No. MAF: 03064

MAF

PERCHA
LP01QTR



CÓDIGO: 14212
No. MAF: 14212

MAF

TUERCA LIVIANA
FINA 5



CÓDIGO: 20048G5
No. MAF: 20048G5

MAF

TORNILLO 5 NF



CÓDIGO: T5F14089
No. MAF: T5F14089

MAF

ASIENTO DE
ABRAZADERAS



CÓDIGO: 22010
No. MAF: AAQ-01

MAF

BUJE NYLON



CÓDIGO: 06094R
No. MAF: BN-02

MAF

TORNILLO "U"
1/2" x 2 1/16" x 6.00"



CÓDIGO: U3B060-A
No. MAF: U-3B060-A

MAF

TORNILLO "U"
1/2" x 2 1/16" x 7 1/2"



CÓDIGO: U3B075-A
No. MAF: U-3B075-A

MAF

TORNILLO CENTRO
3/8" x 2 3/4" x 9/16" x 5/16"



CÓDIGO: 19425
No. MAF: 19425

MAF

TUERCA FINA
3/8" 2



CÓDIGO: 20045
No. MAF: TLF09

MAF

CONJUNTO PERCHAS/
ALBARDÓN

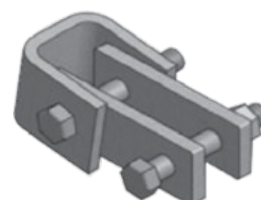

CÓDIGO: 14212A
No. MAF: 14212A

MAF

REMOLQUES

QTR218 (3,500 LBS.), QTR224 (4,800 LBS.),
QTR352 (5,800 LBS.), QTR352R (5,800 LBS.).
POR EJE.



Criterios de Falla Bolsas de aire

Presión baja

Operación de la bolsa de aire sin presión interna de aire provoca que la membrana adopte formas uniformes sobre el pistón y/o arillo intermedio (para bolsas industriales), en vez de mantenerse lisa se mantiene con pliegues.

Esta condición de operación por largos periodos de tiempo reduce la vida útil de la membrana de las bolsas de aire de manera considerable.

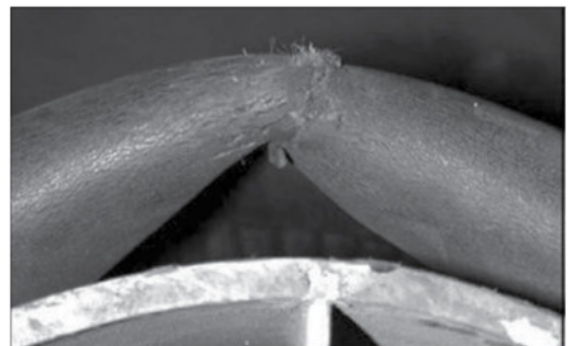

HUTCH

HUTCH CAJAS Y REMOLQUES MODELO 86-94 MUELLE COMPLETA TRA2726M

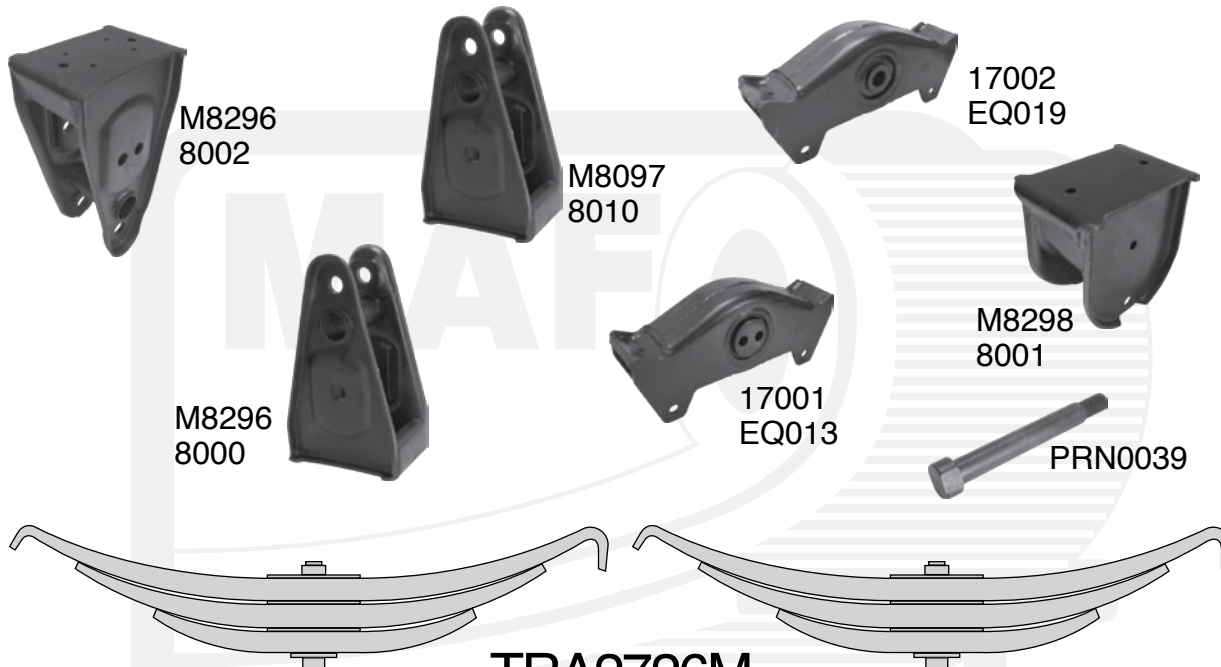

HUTCH

HUTCH CAJAS Y REMOLQUES MODELO 86-94 MUELLE COMPLETA TRA2726M

CÓDIGO	No. MAF	DESCRIPCIÓN	CANTIDAD
8002	8002	PERCHA DELANTERA	2
M8294	M8294	PERCHA DELANTERA	2
8000	8000	PERCHA CENTRAL 2 BARRENOS	2
M8296	M8296	PERCHA CENTRAL 2 BARRENOS	2
8010	8010	PERCHA CENTRAL 1 BARRENO	2
M8097	M8097	PERCHA CENTRAL 1 BARRENO	2
8001	8001	PERCHA TRASERA	2
M8298	M8298	PERCHA TRASERA	2
17001	EQ013	BALANCÍN HUTCHENS SERIE H-7600 C/BUJE	2
17002	EQ019	BALANCÍN HUTCHENS SERIE H-7600 C/BUJE	2
BLN0006	BLN0006	BALANCÍN P/SUSP. UTILITY-HUT. FUNDICIÓN	2
BLN00066010-1T	BLN00066010-1T	BALANCÍN UTILITY- HUTCH CON BUJE 6010-1T	2
BLN00066010T	BLN00066010T	BALANCÍN UTILITY-HUTCH CON BUJE 6010-1T	2
BLN0006PBJ2323	BLN0006PBJ2323	BALANCÍN UTILITY-HUTCH CON BUJE PBJ2323	2
BLN00076009T	BLN00076009T	BALANCÍN HUTCHENS FUND. C/BUJE 6009T	2
BLN0007	BLN0007	BALANCÍN P/SUSP. HUTHES T/S (FUND) PHM 3221	2
BLN0026	BLN0026	BALANCÍN P/SUSP. HUTCHENS T/S (PLACA)	2
BLN0026RE	BLN0026RE	BALANCÍN P/SUSP. HUTCHENS	2
TRB5541	TRB5541=(06861)	BUJE CENTRAL P/BALANCÍN	2
PBJ116	PBJ116	BUJE PARA BALANCÍN TRAILMOBILE	2
GNL0031	GNL-0031	BUJE P/BALANCÍN HUTCHENS	2
6009T	6009	BUJE P/BALANCÍN (TROMPA COCHINO) HUTCH	2
06847	IAR-128	BUJE CENTRAL PARA BALANCÍN HUTCHENS	2
M8284	M8284	ASIENTO PARA EJE HUTCHENS SERIE CH-9700	2
8008	8008	ASIENTO DE MUELLE CAMA REDONDA DE 5"	2
TR005	TR005	TENSOR HUTCHENS FIJO 19 3/4" C/BUJE	2
TR004	TR004	TENSOR HUTCHENS AJUSTABLE C/BUJE	2
2195	2195	TENSOR FIJO P/HULE CON TIPO HUTCH 19 1/4"	2
2123	2123=TNS0018	TENSOR P/ TORTHON 1 x 2 x 3 AJUSTABLE 18 1/4"	2

HUTCH

HUTCH CAJAS Y REMOLQUES MODELO 86-94 MUELLE COMPLETA TRA2726M

CÓDIGO	No. MAF	DESCRIPCIÓN	CANTIDAD
M8286	M8286	CAMA PARA MUELLE	2
7003	7003	TAPA INFERIOR EJE REDONDO	2
TRB5542	TRB5542	BUJE CENTRAL P/BALANCÍN 1 1/8" EQ019	2
PBJ2323	PBJ-2323	BUJE CENTRAL P/BALANCÍN	2
GND0023	GND-0023	PERNO 1.00 INTER. D=1 3/4 E=7 C A C=5,760 TOR 3/8	2
GND0002	GND-0002	BUJE P/BALANCÍN UTILITY 1 1/8"	2
GND0001	GND-0001	BUJE P/BALANCÍN UTILITY 1"	2
6010T	6010T	BUJE PARA BALANCÍN HUTCHENS 1"	2
6010-1T	6010-1	BUJE PARA BALANCÍN HUTCHENS 1 1/8"	2
6002-1T	6002-1	BUJE PARA TORSIÓN 1" 2" 3" C/CASQUILLO	2
6002T	6002	BUJE PARA BARRA TENSOR 1" 2" 3" HUTCHENS	2
6006T	6006	BUJE PARA TENSOR TRAIMOBILE HUTCHENS	2
MH680	MH680	KIT DE TORNILLO P/BALANCÍN EQ013	2
MH456	MH456	SEGURO MARIPOSA HUTCHENS P/BALANCÍN EQ013	2
PBJ10129CP	PBJ10129CP	BUJE C/CASQUILLO P/TIRA REM. 1 x 2 x 3	2
PBJ10129C	PBJ10129C	BUJE C/CASQ. P/TIRANTE 1" x 2" x 3"	2
PBJ10129	PBJ10129	BUJE SIN CASQUILLO PARA TIRANTE 1 x 2 x 3	2
PRN0039	PRN0039	PERNO P/BALANCÍN HUTCHENS	2
TRB6326	TRB6326	BUJE PARA TENSOR HUTCHENS 1.00"	2
PBJ3344	PBJ-3344	BUJE P/TENSOR HUTC. TRAIMOBILE 1 15/16" 1" L 3"	2
PBJ10119P	PBJ-10119P	PBJ10119P BUJE P/TENSOR 1.00"	2
PBJ10119	PBJ-10119	BUJE PARA TIRANTE TENSOR 1 x 2	2
GNL0015	GNL0015	BARRILITO 2.00"	2
6011T	6011	BUJE PARA BARRA DE TORSIÓN CON CUJE HUTCHENS	2
U7E150-C	U-7E150-C	TORNILLO "U" 7/8" x 3 1/16" x 15.00"	8
20057	9055	TUERCA FINA 7/8" 98	8
18009	AR-78	RONDANA DE PRESIÓN 7/8"	8

HUTCH

HUTCH CAJAS Y REMOLQUES MODELO 86-94 MUELLE COMPLETA TRA2726M

CÓDIGO	No. MAF	DESCRIPCIÓN	CANTIDAD
19217	TC-12-4	T.C. 1/2" x 4" (3/4 x 7/16) °8	4
20047	TLF13	TUERCA FINA DE 1/2" °2	4
TRA2726M	TRA-2726M	MUELLE COMPLETA 3 HOJAS	4
		HOJA 1ra 3" x.788"x 24 1/8"x 24 1/2"	

VER CATÁLOGO DE MUELLES MAF 2011



Criterios de Falla Bolsas de aire

Mala alineación

- Bujes dañados.
- Instalación inadecuada de la suspensión.
- Contacto del tope (Bumper) fuera del centro

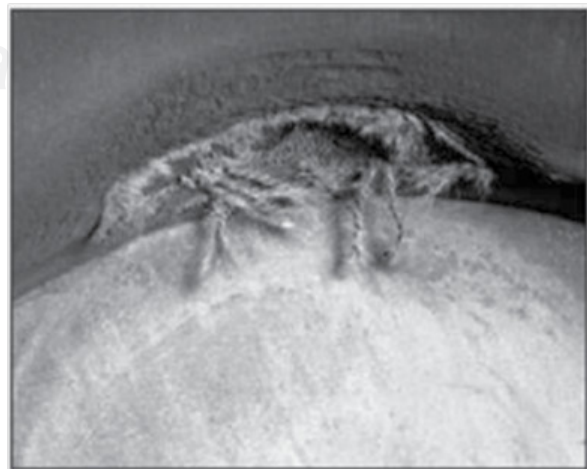
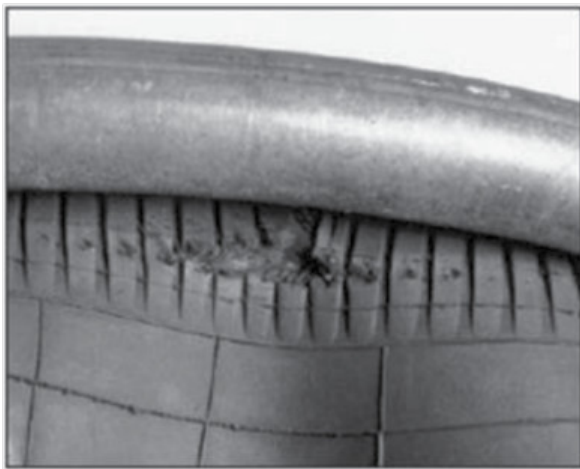

HUTCH

HUTCH CAJAS Y REMOLQUES MODELO 86-94 MUELLE COMPLETA TRA2726M

PERCHA LATERAL
PARA TENSOR



CÓDIGO: 8002
No. MAF: 8002

MAF

PERCHA LATERAL
PARA TENSOR



CÓDIGO: M8294
No. MAF: M8294

MAF

PERCHA CENTRAL 2
BARRENOS



CÓDIGO: 8000
No. MAF: 8000

MAF

PERCHA CENTRAL 2
BARRENOS



CÓDIGO: M86296
No. MAF: M86296

MAF

PERCHA CENTRAL 1
BARRENOS



CÓDIGO: 8010
No. MAF: 8010

MAF

PERCHA CENTRAL
1 BARRENOS



CÓDIGO: M8097
No. MAF: M8097

MAF

PERCHA TRASERA



CÓDIGO: 8001
No. MAF: 8001

MAF

PERCHA TRASERA



CÓDIGO: M8298
No. MAF: M8298

MAF

BALANCÍN CON BUJE
TRB5541



CÓDIGO: 17001
No. MAF: EQ013

MAF

BALANCÍN CON BUJE
TRB5542



CÓDIGO: 17002
No. MAF: EQ019

MAF

BALANCÍN FUNDICIÓN



CÓDIGO: BLN0006
No. MAF: BLN0006

MAF

BALANCÍN FUNDICIÓN



CÓDIGO: BLN0007
No. MAF: BLN0007

MAF

HUTCH

HUTCH CAJAS Y REMOLQUES MODELO 86-94 MUELLE COMPLETA TRA2726M

BUJE CENTRAL HULE
IMPORTADO



CÓDIGO: TRB5541
No. MAF: TRB5541

MAF

BUJE CENTRAL
POLIURETANO



CÓDIGO: 6009T
No. MAF: 6009

MAF

BUJE CENTRAL HULE
NACIONAL



CÓDIGO: 06087
No. MAF: IAR-128

MAF

ASIENTO PARA EJE
IMPORTADO



CÓDIGO: M8284
No. MAF: M8284

MAF

ASIENTO PARA EJE
PHM 5"



CÓDIGO: 8008
No. MAF: 8008

MAF

TENSOR FIJO 19 3/4
CON BUJE



CÓDIGO: TR005
No. MAF: TR005

MAF

TENSOR AJUSTABLE
CON BUJE



CÓDIGO: TR004
No. MAF: TR 004

MAF

TENSOR PARA
TORTON 18 1/4"



CÓDIGO: 2123
No. MAF: TNS0018

MAF

TAPA INFERIOR EJE
REDONDO



CÓDIGO: M8286
No. MAF: M8286

MAF

TAPA INFERIOR EJE
REDONDO FUNDICIÓN



CÓDIGO: 7003
No. MAF: 7003

MAF

BUJE CENTRAL HULE
IMPORTADO



CÓDIGO: TRB5542
No. MAF: TRB5542

MAF

BUJE CENTRAL HULE
NACIONAL



CÓDIGO: PBJ2323
No. MAF: PBJ-2323

MAF

HUTCH

HUTCH CAJAS Y REMOLQUES MODELO 86-94 MUELLE COMPLETA TRA2726M

PERNO
1" x 1 3/4" x 3/8"



CÓDIGO: GND0023
No. MAF: GND0023

MAF

BUJE BALANCÍN



CÓDIGO: GNL0001
No. MAF: GNL-0001

MAF

BUJE BALANCÍN



CÓDIGO: GNL0002
No. MAF: GNL-0002

MAF

BUJE P/BARRA DE
TORSIÓN CON CUJE



CÓDIGO: 6011T
No. MAF: 6011

MAF

BUJE BALANCÍN
INT1



CÓDIGO: 6010T
No. MAF: 6010T

MAF

BUJE BALANCÍN INT 1
1/8"



CÓDIGO: 6010-1T
No. MAF: 6010-1

MAF

BUJE TENSOR



CÓDIGO: 6002-1T
No. MAF: 6002-1

MAF

BUJE TENSOR



CÓDIGO: 6002T
No. MAF: 6002

MAF

BUJE TENSOR



CÓDIGO: 6006T
No. MAF: 6006

MAF

KID TORNILLO P/
BALANCÍN EQ-013



CÓDIGO: MH680
No. MAF: MH680

MAF

SEGURO MARIPOSA P/
BALANCÍN EQ-013



CÓDIGO: MH456
No. MAF: MH456

MAF

BUJE CON CASQUILLO
POLIURETANO
TIRANTE 1, 2, 3



CÓDIGO: PBJ10129CP
No. MAF: PBJ10129CP

MAF

HUTCH

HUTCH CAJAS Y REMOLQUES MODELO 86-94 MUELLE COMPLETA TRA2726M

BUJE CON CASQUILLO
TIRANTE 1, 2, 3



CÓDIGO: PBJ10129C
No. MAF: PBJ10129C
MAF

BUJE SIN CASQUILLO
TIRANTE 1, 2, 3



CÓDIGO: PBJ10129
No. MAF: PBJ10129
MAF

PERNO



CÓDIGO: PRN0039
No. MAF: PRN0039
MAF

BUJE PARA TENSOR 1"



CÓDIGO: TRB6326
No. MAF: TRB6326
MAF

BUJE PARA TENSOR 1
15/16"



CÓDIGO: PBJ3344
No. MAF: PBJ3344
MAF

BUJE PARA TENSOR 1



CÓDIGO: PBJ10119P
No. MAF: PBJ10119P
MAF

BUJE PARA TENSOR
1 x 2



CÓDIGO: PBJ10119
No. MAF: PBJ10119
MAF

BARRILITO



CÓDIGO: GNL0015
No. MAF: GNL0015
MAF

TORNILLO "U"
7/8" x 3 1/16 x 15"



CÓDIGO: U7E150-C
No. MAF: U-7E150-C
MAF

TUERCA FINA 7/8 98



CÓDIGO: 20057
No. MAF: 9055
MAF

RONDANA DE PRESIÓN
7/8



CÓDIGO: 18009
No. MAF: AR-78
MAF

TORNILLO DE CENTRO
1/2" x 4"



CÓDIGO: 19217
No. MAF: TC-12-4
MAF

HUTCH

HUTCH CAJAS Y REMOLQUES MODELO 86-94 MUELLE COMPLETA TRA2726M

TUERCA UNF °2 DE 1/2"



CÓDIGO: 20047
No. MAF: TL13

MAF

BALANCÍN P/
SUSPENSIÓN HUTCH
T/S (PLACA)

CÓDIGO: BLN0026
No. MAF: BLN0026

MAF

BUJE P/BALANCÍN
TRAILMOBILE

CÓDIGO: BLN0026
No. MAF: BLN0026

MAF



Criterios de Falla Bolsas de aire

Cortes en la circunferencia

- Alta presión, extensión total por largos periodos de tiempo.
- Impacto en la posición de compresión.



HUTCH

HUTCH CAJAS Y REMOLQUES
4 MUELLE TRA2727



HUTCH

HUTCH CAJAS Y REMOLQUES
4 MUELLE TRA2727

CÓDIGO	No. MAF	DESCRIPCIÓN	CANTIDAD
8002	8002	PERCHA DELANTERA	2
M8294	M8294	PERCHA DELANTERA	2
8000	8000	PERCHA CENTRAL 2 BARRENOS	2
M8296	M8296	PERCHA CENTRAL 2 BARRENOS	2
8010	8010	PERCHA CENTRAL 1 BARRENO	2
M8097	M8097	PERCHA CENTRAL 1 BARRENO	2
8001	8001	PERCHA TRASERA	2
M8298	M8298	PERCHA TRASERA	2
17001	EQ013	BALANCÍN HUTCHENS SERIE H-7600 C/BUJE	2
17002	EQ019	BALANCÍN HUTCHENS SERIE H-7600 C/BUJE	2
BLN0006	BLN0006	BALANCÍN P/SUSP. UTILITY-HUT. (FUNDIC).	2
BLN00066010-1T	BLN00066010-1T	BALANCÍN UTILITY- HUTCH CON BUJE 6010-1T	2
BLN00066010T	BLN00066010T	BALANCÍN UTILITY-HUTCH CON BUJE 6010-1T	2
BLN0006PBJ2323	BLN0006PBJ2323	BALANCÍN UTILITY-HUTCH CON BUJE PBJ2323	2
BLN00076009T	BLN00076009T	BALANCÍN HUTCH FUNDICIÓN C/BUJE 6009T	2
BLN0007	BLN0007	BALANCÍN P/SUSP. HUTCH T/S (FUND) PHM 3221	2
BLN0026	BLN0026	BALANCÍN P/SUSPENSIÓN HUTCH T/S (PLACA)	2
BLN0026RE	BLN0026RE	BALANCÍN P/SUSPENSIÓN HUTCH	2
TRB5541	TRB5541=(06861)	BUJE CENTRAL P/BALANCÍN	2
PBJ116	PBJ116	BUJE PARA BALANCÍN TRAILMOBILE	2
GNL0031	GNL-0031	BUJE P/BALANCÍN HUTCH	2
6009T	6009	BUJE P/BALANCÍN (TROMPA COCHINO) HUTCH	2
06847	IAR-128	BUJE CENTRAL PARA BALANCÍN HUTCH	2
M8284	M8284	ASIEN TO PARA EJE HUTCH SERIE CH-9700	2
8008	8008	ASIEN TO DE MUELLE CAMA REDONDADA DE 5"	2
TR005	TR005	TENSOR HUTCHENS FIJO 19 3/4" C/BUJE	2
TR004	TR004	TENSOR HUTCHENS AJUSTABLE C/BUJE	2
2195	2195	TENSOR FIJO P/HULE C/TIPO HUTCH 19 1/4"	2
2123	2123=TSN0018	TENSOR P/ TORTHON 1 x 2 x 3 AJUSTABLE 18 1/4"	2

HUTCH HUTCH CAJAS Y REMOLQUES 4 MUELLE TRA2727

CÓDIGO	No. MAF	DESCRIPCIÓN	CANTIDAD
M8286	M8286	CAMA PARA MUELLE	2
7003	7003	TAPA INFERIOR EJE REDONDO	2
TRB5542	TRB5542	BUJE CENTRAL P/BALANCÍN 1 1/8" EQ019	2
PBJ2323	PBJ-2323	BUJE CENTRAL P/BALANCÍN	2
GND0023	GND-0023	PERNO 1.00 INTER. D=1 3/4" E=7 C A C=5,760 TOR. 3/8"	2
GND0002	GND-0002	BUJE P/BALANCÍN UTILITY 1 1/8"	2
GND0001	GND-0001	BUJE P/BALANCÍN UTILITY 1"	2
6010T	6010T	BUJE PARA BALANCÍN HUTCH 1"	2
6010-1T	6010-1	BUJE PARA BALANCÍN HUTCH 1 1/8"	2
6002-1T	6002-1	BUJE PARA TORSIÓN 1" 2" 3" C/CASQUILLO	2
6002T	6002	BUJE PARA BARRA TENSOR 1" 2" 3" HUTCH	2
6006T	6006	BUJE PARA TENSOR TRAIMOBILE HUTCH	2
MH680	MH680	KIT DE TORNILLO P/BALANCÍN EQ013	2
MH456	MH456	SEGURO MARIPOSA HUTCH P/BALANCÍN EQ013	2
PBJ10129C	PBJ10129C	BUJE CON CASQ. PARA TIRANTE 1" x 2" x 3"	2
PBJ10129	PBJ10129	BUJE SIN CASQUILLO PARA TIRANTE 1 x 2 x 3	2
PRN0039	PRN0039	PERNO P/BALANCÍN HUTCH	2
TRB6326	TRB6326	BUJE PARA TENSOR HUTCH 1.00"	2
PBJ3344	PBJ3344	BUJE P/TENSOR HUTCH TRAIMOBILE 1 15/16" 1 L 3	2
PBJ10119P	PBJ10119P	PBJ10119P BUJE P/TENSOR 1.00"	2
PBJ10119	PBJ10119	BUJE PARA TIRANTE TENSOR 1 x 2	2
GL0015	GL0015	BARRILITO 2.00"	2
6011T	6011	BUJE PARA BARRA DE TORSIÓN C/BUJE HUTCH	2
U7E150C	U7E150-C	TORNILLO "U" 7/8" x 3 1/16" x 15.00"	8
20057	9055	TUERCA FINA 7/8" °8	8
18009	AR-78	RONDANA DE PRESIÓN 7/8"	8
19217	TC-12-4	T.C. 1/2" x 4" (3/4 x 7/16) °8	1

HUTCH

HUTCH CAJAS Y REMOLQUES 4 MUELLE TRA2727

CÓDIGO	No. MAF	DESCRIPCIÓN	CANTIDAD
20047	TLF13	TUERCA FINA DE 1/2 2"	1
TRA2727	TRA2727	MUELLE COMPLETA 3 HOJAS	2

HOJA 1ra 3" x .788" x 23 5/8" x 23 1/2"

VER CATÁLOGO DE MUELLES MAF 2011



Criterios de Falla Bolsas de aire

Anillo intermedio suelto

Operación en posiciones extendidas con baja presión de aire.



HUTCH

HUTCH CAJAS Y REMOLQUES 4 MUELLE TRA2727

PERCHA LATERAL
PARA TENSOR



CÓDIGO: 8002
No. MAF: 8002

MAF

PERCHA LATERAL
PARA TENSOR



CÓDIGO: M8294
No. MAF: M8294

MAF

PERCHA CENTRAL 2
BARRENOS



CÓDIGO: 8000
No. MAF: 8000

MAF

PERCHA CENTRAL 2
BARRENOS



CÓDIGO: M86296
No. MAF: M86296

MAF

PERCHA CENTRAL 1
BARRENOS



CÓDIGO: 8010
No. MAF: 8010

MAF

PERCHA CENTRAL
1 BARRENOS



CÓDIGO: M8097
No. MAF: M8097

MAF

PERCHA TRASERA



CÓDIGO: 8001
No. MAF: 8001

MAF

PERCHA TRASERA



CÓDIGO: M8298
No. MAF: M8298

MAF

BALANCÍN CON BUJE
TRB5541



CÓDIGO: 17001
No. MAF: EQ013

MAF

BALANCÍN CON BUJE
TRB5542



CÓDIGO: 17002
No. MAF: EQ019

MAF

BALANCÍN FUNDICIÓN



CÓDIGO: BLN0006
No. MAF: BLN0006

MAF

BALANCÍN FUNDICIÓN



CÓDIGO: BLN0007
No. MAF: BLN0007

MAF

HUTCH

HUTCH CAJAS Y REMOLQUES 4 MUELLE TRA2727

BUJE CENTRAL HULE
IMPORTADO



CÓDIGO: TRB5541
No. MAF: TRB5541

MAF

BUJE CENTRAL
POLIURETANO



CÓDIGO: 6009T
No. MAF: 6009

MAF

BUJE CENTRAL HULE
NACIONAL



CÓDIGO: 06087
No. MAF: IAR 128

MAF

ASIENTO PARA EJE
IMPORTADO



CÓDIGO: M8284
No. MAF: M8284

MAF

ASIENTO PARA EJE
PHM 5"



CÓDIGO: 8008
No. MAF: 8008

MAF

TENSOR FIJO 19 3/4
CON BUJE



CÓDIGO: TR005
No. MAF: TR005

MAF

TENSOR AJUSTABLE
CON BUJE



CÓDIGO: TR004
No. MAF: TR 004

MAF

TENSOR PARA
TORTON 18 1/4"



CÓDIGO: 2123
No. MAF: TNS0018

MAF

TAPA INFERIOR EJE
REDONDO



CÓDIGO: M8286
No. MAF: M8286

MAF

TAPA INFERIOR EJE
REDONDO FUNDICIÓN



CÓDIGO: 7003
No. MAF: 7003

MAF

BUJE CENTRAL HULE
IMPORTADO



CÓDIGO: TRB5542
No. MAF: TRB5542

MAF

BUJE CENTRAL HULE
NACIONAL



CÓDIGO: PBJ2323
No. MAF: PBJ2323

MAF

HUTCH

HUTCH CAJAS Y REMOLQUES 4 MUELLE TRA2727

PERNO
1" x 1 3/4" x 3/8"



CÓDIGO: GND0023
No. MAF: GND0023

MAF

BUJE BALANCÍN



CÓDIGO: GNL0001
No. MAF: GNL-0001

MAF

BUJE BALANCÍN



CÓDIGO: GNL0002
No. MAF: GNL-0002

MAF

BUJE P/BARRA DE TORSIÓN CON CUJE



CÓDIGO: 6011T
No. MAF: 6011

MAF

BUJE BALANCÍN INT1



CÓDIGO: 6010T
No. MAF: 6010

MAF

BUJE BALANCÍN INT 1 1/8"



CÓDIGO: 6010-1T
No. MAF: 6010-1

MAF

BUJE TENSOR



CÓDIGO: 6002-1T
No. MAF: 6002-1

MAF

BUJE TENSOR



CÓDIGO: 6002T
No. MAF: 6002

MAF

BUJE TENSOR



CÓDIGO: 6006T
No. MAF: 6006

MAF

KIT TORNILLO P/ BALANCÍN EQ-013



CÓDIGO: MH680
No. MAF: MH680

MAF

SEGURO MARIPOSA P/ BALANCÍN EQ-013



CÓDIGO: MH456
No. MAF: MH456

MAF

BUJE CON CASQUILLO TIRANTE 1, 2, 3



CÓDIGO: PBJ10129C
No. MAF: PBJ10129C

MAF

HUTCH

HUTCH CAJAS Y REMOLQUES 4 MUELLE TRA2727

BUJE SIN CASQUILLO
TIRANTE 1, 2, 3



CÓDIGO: PBJ10129
No. MAF: PBJ10129

MAF

PERNO



CÓDIGO: PRN0039
No. MAF: PRN0039

MAF

BUJE P/TENSOR 1"



CÓDIGO: TRB6326
No. MAF: TRB6326

MAF

BARRILITO



CÓDIGO: GLN0015
No. MAF: GLN0015

MAF

BUJE PARA TENSOR 1
15/16"



CÓDIGO: PBJ3344
No. MAF: PBJ3344

MAF

BUJE PARA TENSOR 1



CÓDIGO: PBJ10119P
No. MAF: PBJ10119P

MAF

BUJE PARA TENSOR
1 x 2



CÓDIGO: PBJ10119
No. MAF: PBJ10119

MAF

TORNILLO "U" 7/8" X 3
1/16" x 15"



CÓDIGO: U7E150C
No. MAF: U7E150-C

MAF

TUERCA UNF #2 DE 1/2"



CÓDIGO: 20047
No. MAF: TLF13

MAF

TUERCA FINA
7/8" #8



CÓDIGO: 20057
No. MAF: 9055

MAF

RONDANA DE PRESIÓN
7/8"



CÓDIGO: 18009
No. MAF: AR-78

MAF

TORNILLO DE CENTRO
1/2" x 4"



CÓDIGO: 19217
No. MAF: TC-12-4

MAF

NOTAS



Garantía en Calidad y Servicio

REYCO

SUSPENSIÓN REYCO
TRACTOR KENWORTH T300
MUELLE KWT359

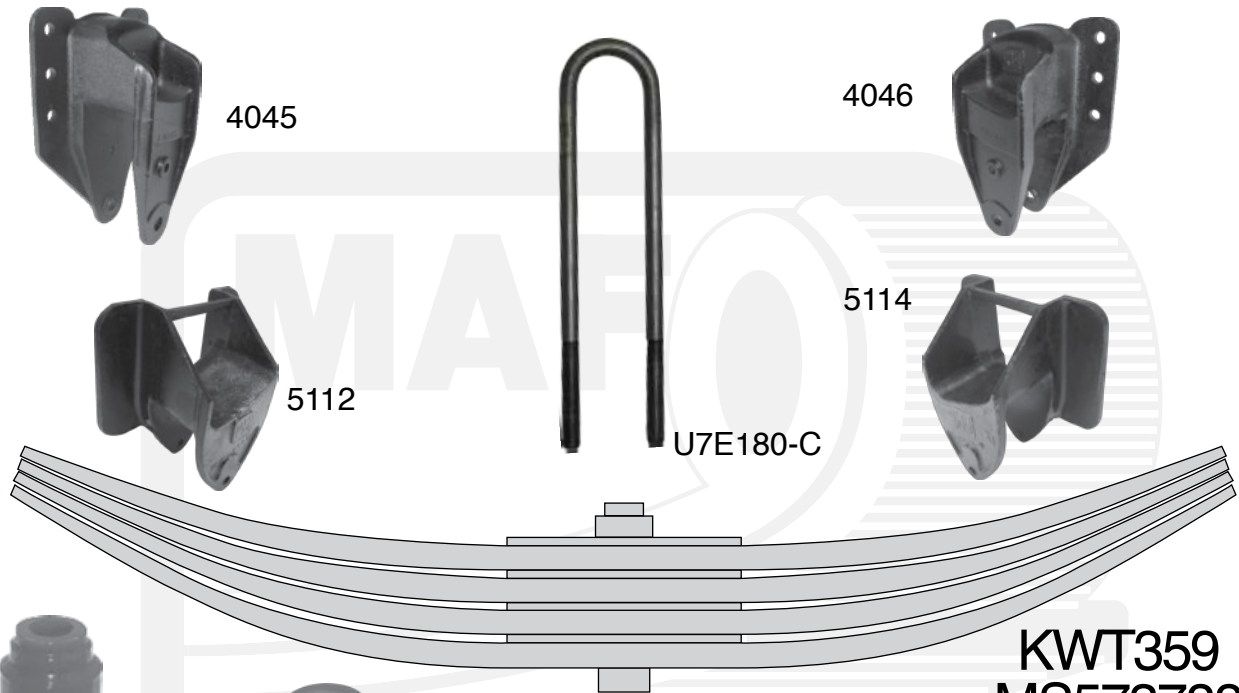

KWT359
MS573788
83257F

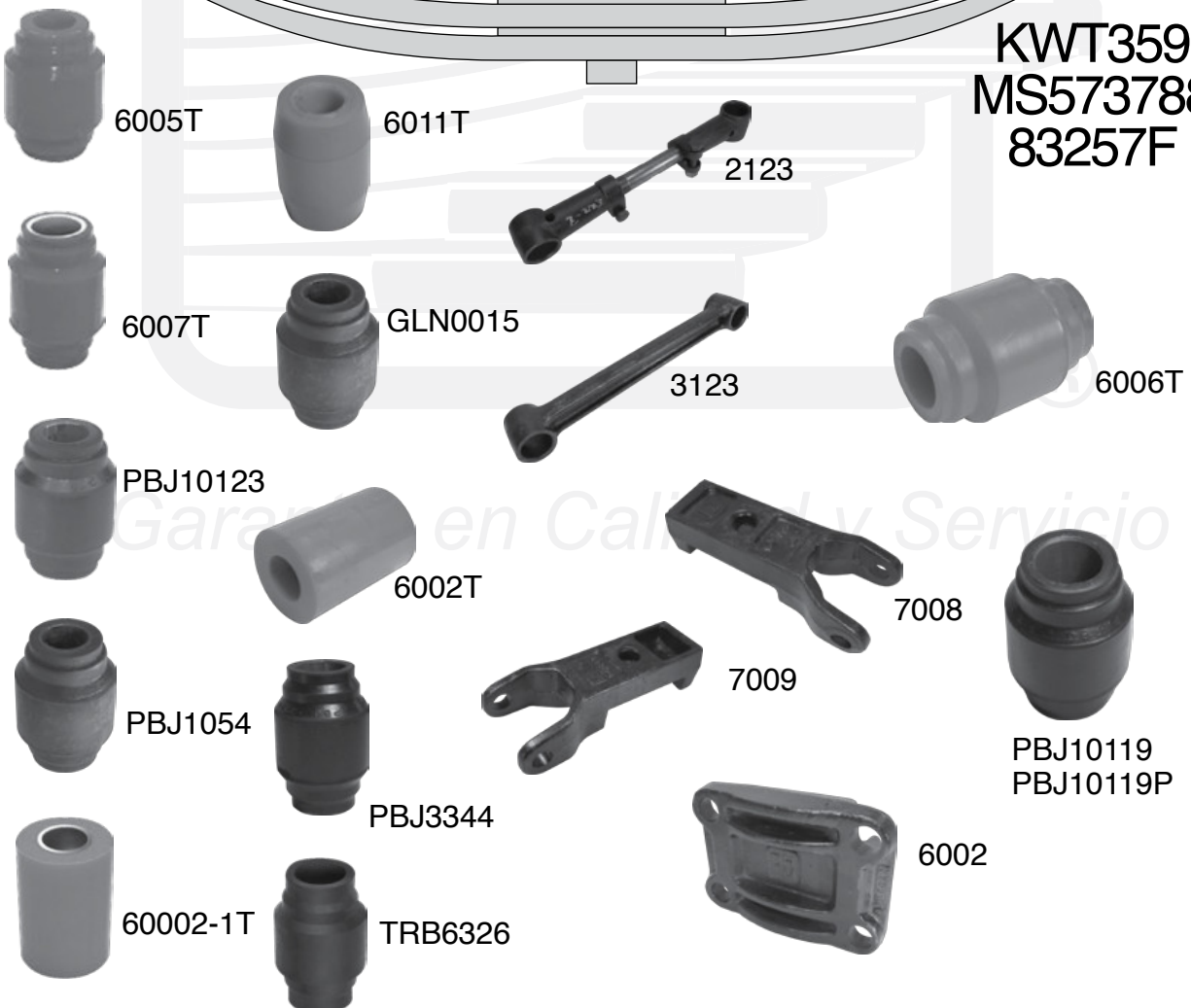

REYCO

SUSPENSIÓN REYCO TRACTOR KENWORTH T300 MUELLE KWT359

CÓDIGO	No. MAF	DESCRIPCIÓN	CANTIDAD
4045	4045	PERCHA DELANTERA REYCO IZQ. # ORIG. 12801-01	1
4046	4046	PERCHA DELANTERA REYCO DER. #ORIG. 12802-01	1
5112	5112	PERCHA TRAS. TRAS. IZQ. SUSP. REYCO T/VIEJO ACE	1
5114	5114	PERCHA TRAS. TRAS. DER. SUSP. REYCO T/VIEJO ACE	1
6005T	6005	BUJE PARA TENSOR TRAIMOBILE HUTCHENS	2
6007T	6007	BUJE P/TENSOR TRAILMOBILE	2
PBJ10123	PBJ10123	BUJE P/TENS. SUSP. REYCO-HEND 09729-01	2
PBJ1054	PBJ-1054	BUJE PARA TENSOR ROCCSA DE 2 7/8" L 3	2
3123	3123	TENSOR FIJO 1 x 2 x 3 FIJO 19" KENWORTH	2
2123	2123=TNS0018	TENSOR PARA TORTHON 1 x 2 x 3 AJUSTABLE 18 1/4"	2
6002	6002	TAPA INFERIOR DIFERENCIAL 4 3/4" NAVISTAR	2
7008	7008	CUÑA SOPORTE TENSOR SIN GRADOS REYCO	2
7009	7009	CUÑA SOPORTE TENSOR REYCO	2
6002-1T	6002-1	BUJE P/BARRA TORSIÓN 1",2",3" C/CASQUILLO	2
6002T	6002	BUJE P/ BARRA TENSOR 1",2",3" HUTCHENS	2
6006T	6006	BUJE PARA TENSOR TRAIMOBILE HUTCHENS	2
6011T	6011	BUJE PARA BARRA DE TORSIÓN CON CUJE HUTCHENS	2
GNL0015	GNL-0015	BARRILITO 2.00"	2
PBJ10119	PBJ-10119	BUJE PARA TIRANTE TENSOR 1 x 2	2
PBJ10119P	PBJ10119P	BUJE P/TENSOR 1.00"	2
PBJ3344	PBJ-3344	BUJE P/TENSOR HUTCH TRAILMOBILE 1 15/16" 1" L3"	2
TRB6326	TRB6326	BUJE PARA TENSOR HUTCHENS 1.00"	2
U7E180-C	U-7E180-C	TORNILLO "U" 7/8" x 3 1/16" x 18.00"	4
KWT359	KWT-359	MUELLE DE 4 HOJAS	2
		HOJA-01 3" x .999" x 29 5/8" x 29 5/8"	
MS573788	MS573788	MUELLE DE 4 HOJAS	2
		MUELLE-01 3" x .788" x 29 5/8" x 29 5/8"	
83257F	83-257F	MUELLE DE 4 HOJAS	2
		MUELLE -01 3" x .788" x 28 7/8" x 28 7/8"	

VER CATALOGO DE MUELLES MAF 2011

REYCO

SUSPENSIÓN REYCO TRACTOR KENWORTH T300 MUELLE KWT359

PERCHA DELANTERA
IZQ.



CÓDIGO: 4045
No. MAF: 4045

MAF

PERCHA DELANTERA



CÓDIGO: 4046
No. MAF: 4046

MAF

PERCHA TRAS. TRAS.
IZQ.



CÓDIGO: 5112
No. MAF: 5112

MAF

PERCHA TRA. TRAS.
DER.



CÓDIGO: 5114
No. MAF: 5114

MAF

BUJE P/TENSOR
TRAILMOBILE
HUTCHENS



CÓDIGO: 6005T
No. MAF: 6005

MAF

BUJE P/TENSOR
TRAILMOBILE



CÓDIGO: 6007T
No. MAF: 6007

MAF

BUJE P/TENS. SUSP.
REYCO-HEND 09729-01



CÓDIGO: PBJ10123
No. MAF: PBJ10123

MAF

BUJE P/TENSOR
ROCCSA DE 2 7/8" L3



CÓDIGO: PBJ1054
No. MAF: PBJ-054

MAF

TENSOR FIJO 1 x 2 x 3
FIJO 19" KENWORTH



CÓDIGO: 3123
No. MAF: 3123

MAF

PERCHA TENSOR PARA
TORTON 1 x 2 x 3
AJUSTABLE 18 1/4"



CÓDIGO: 2123
No. MAF: TNS0018

MAF

TAPA INFERIOR
DIFERENCIAL 4 3/4"
NAVISTAR



CÓDIGO: 6002
No. MAF: 6002

MAF

CUÑA SOPORTE
TENSOR SIN GRADOS
REYCO



CÓDIGO: 7008
No. MAF: 7008

MAF

REYCO

SUSPENSIÓN REYCO TRACTOR KENWORTH T300 MUELLE KWT359

CUÑA SOPORTE
TENSOR REYCO



CÓDIGO: 7009
No. MAF: 7009

MAF

BUJE P/BARRA
TORSIÓN 1", 2", 3"
C/CASQUILLO



CÓDIGO: 6002-1T
No. MAF: 6002-1

MAF

BUJE P/BARRA
TENSOR 1", 2", 3"
HUTCHENS



CÓDIGO: 6002T
No. MAF: 6002

MAF

BUJE P/TENSOR
TRAILMOBILE
HUTCHENS



CÓDIGO: 6006T
No. MAF: 6006

MAF

BUJE PARA BARRA DE
TORSIÓN CON CUJE
HUTCHENS



CÓDIGO: 6011T
No. MAF: 6011

MAF

BARRILITO 2.00"



CÓDIGO: GNL0015
No. MAF: GNL-0015

MAF

BUJE P/TIRANTE
TENSOR 1 x 2



CÓDIGO: PBJ10119
No. MAF: PBJ-10119

MAF

BUJE P/TENSOR 1.00"



CÓDIGO: PBJ10119P
No. MAF: PBJ10119P

MAF

BUJE P/TENSOR
HUTCH TRAILMOBILE 1
15/16" 1" L3"



CÓDIGO: PBJ3344
No. MAF: PBJ-3344

MAF

BUJE P/TENSOR
HUTCHENS 1.00



CÓDIGO: TRB6326
No. MAF: TRB6326

MAF

TORNILLO "U"
7/8" x 3 1/16" x 18.00"



CÓDIGO: U7E180-C
No. MAF: U-7E180-C

MAF

VOLVO

MUELLE VOLVO
2 HOJAS VNL MODELO (1997-2000)
PARABÓLICA 961308AF

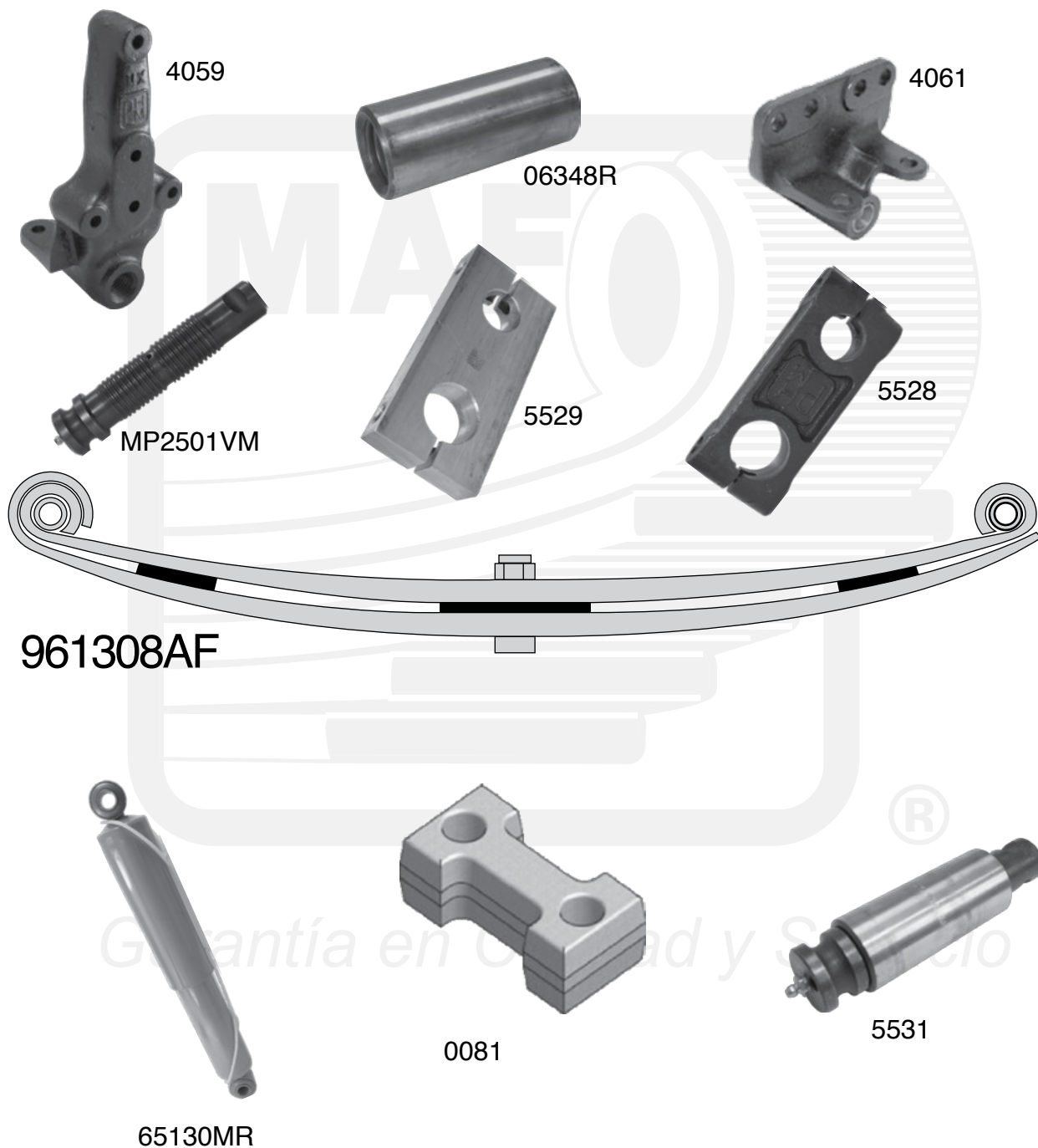

VOLVO

MUELLE VOLVO
2 HOJAS VNL MODELO (1997-2000)
PARABÓLICA 961308AF

CÓDIGO	No. MAF	DESCRIPCIÓN	CANTIDAD
5531	5531	PERNO Y BUJE ROS. MM. VOLVO P/ALBARDÓN	2
65130MR	65130	65130 AMORT. MONROE = 85061 MERITOR	1
0081	0081	TACÓN CUÑA SUSPENSIÓN VOLVO	2
5528	5528	ALBARDÓN VOLVO FUNDICIÓN P/PERNO 1-5531	2
06348R	06348R	BUJE ROSCADO TB-77 mm 1 3/4" x 4.00"	2
4061	4061	PERCHA COLUMPIO ROSCADA 33mm VOLVO	2
4059	4059	PERCHA PARTE COLUMPIO DEL. TRAS. VOLVO	2
MP2501VM	MP2501VM	PERNO ROSCADO VOLVO MILIMÉTRICO	2
5529	5529	ALBARDÓN VOLVO ALUMINIO P/PERNO 1-5531	2
961308AF	96-1308AF	MUELLE DE 2 HOJAS	2

HOJA 01 4" x .999" x 27 9/16" x 31 1/4"

VER CATÁLOGO DE MUELLES 2011



Garantía en Calidad y Servicio

MUELLE VOLVO 2 HOJAS VNL MODELO (1997-2000) PARABÓLICA 961308AF

PERNO Y BUJE
ROS. MM. VOLVO P/
ALBARDÓN 5528 Y 5529



CÓDIGO: 5531
No. MAF: 5531

MAF

65130 AMORT.
MONROE = 85061
MERITOR



CÓDIGO: 65130MR
No. MAF: 65130

MAF

TACÓN CUÑA

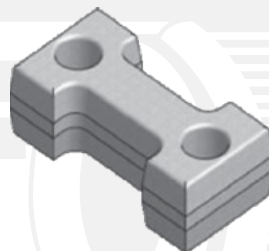

CÓDIGO: 0081
No. MAF: 0081

MAF

ALBARDÓN VOLVO
FUNDICIÓN P/PERNO
1-5531



CÓDIGO: 5528
No. MAF: 5528

MAF

BUJE ROSCADO TB-
77mm 1 3/4" x 4.00"
(M32 x 4-90)



CÓDIGO: 06348R
No. MAF: 06348R

MAF

PERCHA COLUMPIO
ROSCADA 33mm
VOLVO



CÓDIGO: 4061
No. MAF: 4061

MAF

AMORTIGUADOR
PERCHA PARTE
COLUMPIO DEL TRAS
VOLVO MERITOR



CÓDIGO: 4059
No. MAF: 4059

MAF

PERNO ROSCADO
VOLVO MILIMÉTRICO



CÓDIGO: MP2501VM
No. MAF: MP2501VM

MAF

ALBARDÓN VOLVO
ALUMINIO P/PERNO
1-5531



CÓDIGO: 5529
No. MAF: 5529

MAF

Garantía en Calidad y Servicio

VOLVO

VOLVO
SUSPENSIÓN AIR RIDE
MUELLE "Z" 96103



4036



U6E160-C



1R12090 GOODYEAR
1R12182 GOODYEAR
64259 CONTITECH
64262 CONTITECH



5018

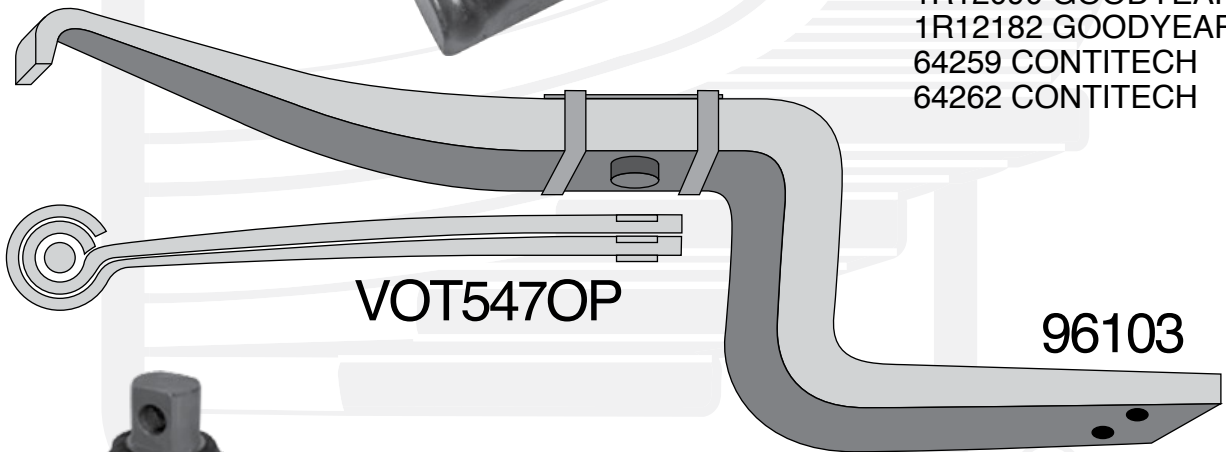

VOT547OP

96103



06325R
(RB-259)
TSP259R-POL



74412MR MERITOR
85704A MONROE

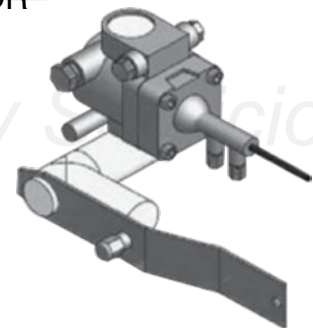

171H00450CE



227710
TSP259R-HUL

MVV12

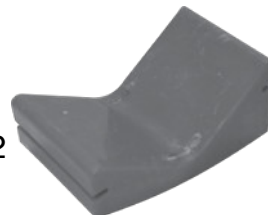

Garantía en Calidad y Servicio

VOLVO

VOLVO
SUSPENSIÓN AIR RIDE
MUELLE "Z" 96103

CÓDIGO	No. MAF	DESCRIPCIÓN	CANTIDAD
4036	4036	PERCHA DEL. SUSP. AIRE Y MECÁNICA FUND.	2
171H00450CE	171H00450CE	VÁLVULA NIVELADORA HADLEY UNIVERSAL	1
06325R	RB-259	GRANADA	2
227710	227710	P/B TORSIÓN # ORIG. 44694 CLEVITE	2
TSP259R-HUL	200-44694	IARSA No.4694=TRB6164 HEND.P/B TORSIÓN	2
TSP259R-POL	TSP259R	BUJE PARA BARRA DE TORSIÓN POLIURETANO	2
5018	5018	ASIENTO DE BRAZADERA	2
1R12090	1R12090	W013589213 BOLSA DE AIRE GOODYEAR	2
1R12182	1R12182	W013589219 BOLSA DE AIRE GOODYEAR	2
64259	64259	BOLSA DE AIRE CONTITECH	2
64262	64262	BOLSA DE AIRE CONTITECH	2
74412MR	74412	AMORTIGUADOR MONROE = 85704 MERITOR	2
MVV12	MVV12	SOPORTE SUSPENSIÓN AIRE TRAS. VOLVO	2
85704A	85704	AMORT. MERITOR = 74412 MONROE	2
U6E160-C	U-6E160-C	TORNILO "U" 3/4" x 3 1/16" x 16.00"	2
96103	96-103	MUELLE TIPO "Z" 3" x 1.750" x 23 3/4" x 19 1/8"	2
VOT547OP	VOT-547-OP	VOT-547-OP HOJA GUÍA 3" x .662" x 23" x 4"	2
VOT547OPRFZO	VOT-547-OP	VOT-547-OP HOJA REFUERZO 3" x .662" x 23" x 4"	2

VER CATÁLOGO DE MUELLES MAF 2011

Garantía en Calidad y Servicio

VOLVO

VOLVO

SUSPENSIÓN AIR RIDE

MUELLE "Z" 96103

PERCHA DEL. SUSP.
AIRE



CÓDIGO: 4036
No. MAF: 4036

MAF

VÁLVULA NIVELADORA
HADLEY UNIVERSAL
GRANADA

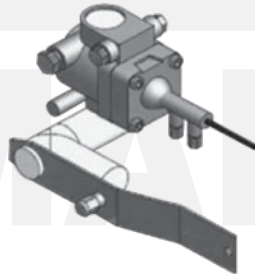

CÓDIGO: 171H00450CE
No. MAF: 171H00450CE

MAF

GRANADA 44694
CLEVITE



CÓDIGO: 06325R
No. MAF: RB-259

MAF

GRANADA PARA BARRA
DE TORSIÓN HULE
CLEVITE



CÓDIGO: 227710
No. MAF: 227710

MAF

GRANADA PARA BARRA
DE TORSIÓN HULE



CÓDIGO: TSP259R-HUL
No. MAF: 200-44694

MAF

BUJE PARA BARRA
DE TORSIÓN
POLIURETANO



CÓDIGO: TSP259R-POL
No. MAF: TSP259R

MAF

ASIENTO DE
BRAZADERA



CÓDIGO: 5018
No. MAF: 5018

MAF

BOLSA DE AIRE
GOODYEAR



CÓDIGO: 1R12090
No. MAF: 1R12090

MAF

BOLSA DE AIRE
GOODYEAR



CÓDIGO: 1R12182
No. MAF: 1R12182

MAF

BOLSA DE AIRE
CONTITECH



CÓDIGO: 64259
No. MAF: 64259

MAF

BOLSA DE AIRE
CONTITECH



CÓDIGO: 64262
No. MAF: 64262

MAF

AMORT. MONROE



CÓDIGO: 74412MR
No. MAF: 74412

MAF

VOLVO

VOLVO
SUSPENSIÓN AIR RIDE
MUELLE "Z" 96-103

AMORT. MERITOR

CÓDIGO: 85704A
No. MAF: 85704

MAF

TORNILLO "U"
3/4" x 3 1/16" x 16.00"CÓDIGO: U6E160-C
No. MAF: U-6E160-C

MAF

SOPORTE

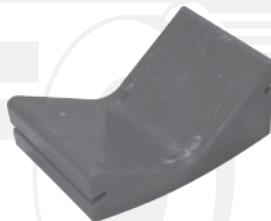
CÓDIGO: MVV12
No. MAF: MVV12

MAF

A large, faint, light-gray diagram of a Volvo Air Ride suspension system, showing the air lines, air springs, and the "Z" spring assembly. A registered trademark symbol (®) is located at the bottom right of the diagram.

Garantía en Calidad y Servicio

VOLVO

VOLVO
TRACTO WG, WL, WHE
MUELLE DEL PARABÓLICA 94200F

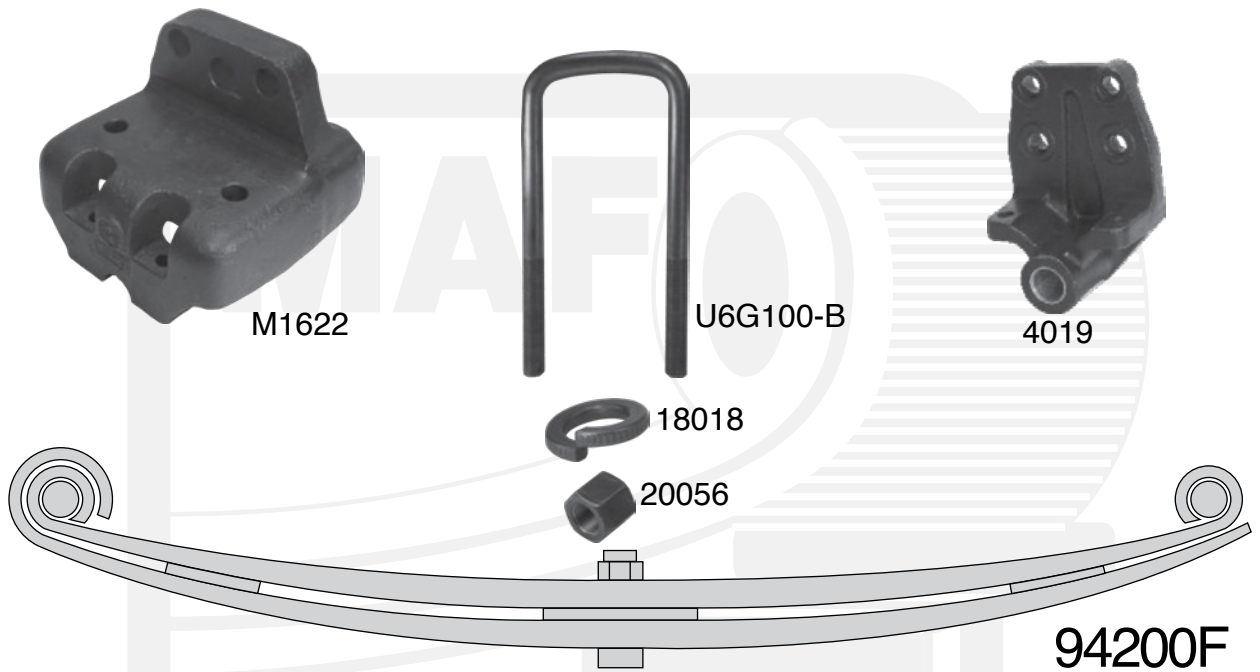

06167BMR
PLK BRONCE



03051
(A-38-A)



4025



06167R
PLK BI-METÁLICO



PRN0038



66714



66903

VOLVO

VOLVO
TRACTO WG, WL, WHE
MUELLE DEL PARABÓLICA 94200F

CÓDIGO	No. MAF	DESCRIPCIÓN	CANTIDAD
4025	4025	PERCHA PARTE COLUMPIO VOLVO 2 BARRENOS	2
4019	4019	PERCHA PARTE COLUMPIO VOLVO 4 BARRENOS	2
U6G100-B	U-6G100-B	TORNILLO "U" 3/4" x 4 1/16" x 10.00"	4
M1622	M1622	PERCHA VOLVO No. ORIG. 371030019 FUNDICIÓN	4
06167BMR	PLK	BUJE BI-METÁLICO 1 3/8" x 1.135" x 4.00"	4
06167R	PLK	BUJE BRONCE 1 3/8" x 1 1/8" x 4.00"	4
PRN0038	PRN0038	PERNO 1 1/8" P/SUSP. VOLVO	4
03051	A-38-A	AAL0017 ALBARDÓN ALUMINIO VOLVO	4
66714	66714	AMORTIGUADOR	2
66903	66903	AMORTIGUADOR	2
18018	ARA436-34	RONDANA AUTOMOTRIZ 436 TEMP. 3/4"	4
20056	9054	TUERCA FINA ALTA 3/4" 9054 °8	4
94200F	94-200F	MUELLE PARABOLICA DE 3 HOJAS VOLVO	

VER CATÁLOGO DE MUELELS MAF 2011



Garantía en Calidad y Servicio

VOLVO

VOLVO

TRACTO WG, WL, WHE

MUELLE DEL PARABÓLICA 94200F

PERCHA PARTE
COLUMPIO VOLVO 2
BARRENOS



CÓDIGO: 4025
No. MAF: 4025

MAF

PERCHA PARTE
COLUMPIO VOLVO 4
BARRENOS



CÓDIGO: 4019
No. MAF: 4019

MAF

TORNILLO "U"
3/4X4 1/16 X 10.00



CÓDIGO: U6G100-B
No. MAF: U-6G100-B

MAF

PERCHA
FUNDICIÓN



CÓDIGO: M1622
No. MAF: M1622

MAF

BUJE BI-METÁLICO
1 3/8" x 1.135 x 4.00"



CÓDIGO: 06167BMR
No. MAF: PLK

MAF

BUJE BRONCE 1
3/8" x 1 1/8" x 4.00"



CÓDIGO: 06167R
No. MAF: PLK

MAF

PERNO 1 1/8"
P/SUSP. VOLVO



CÓDIGO: PRN0038
No. MAF: PRN0038

MAF

ALBARDÓN ALUMINIO
VOLVO



CÓDIGO: 03051
No. MAF: A-38-A

MAF

AMORTIGUADOR



CÓDIGO: 66714
No. MAF: 66714

MAF

AMORTIGUADOR



CÓDIGO: 66903
No. MAF: 66903

MAF

RONDANA 3/4"
TEMPLADA



CÓDIGO: 18018
No. MAF: ARA436-34

MAF

TUERCA FINA 3/4"



CÓDIGO: 20056
No. MAF: 9054

MAF

NOTAS



Garantía en Calidad y Servicio

TORNILLOS “U”

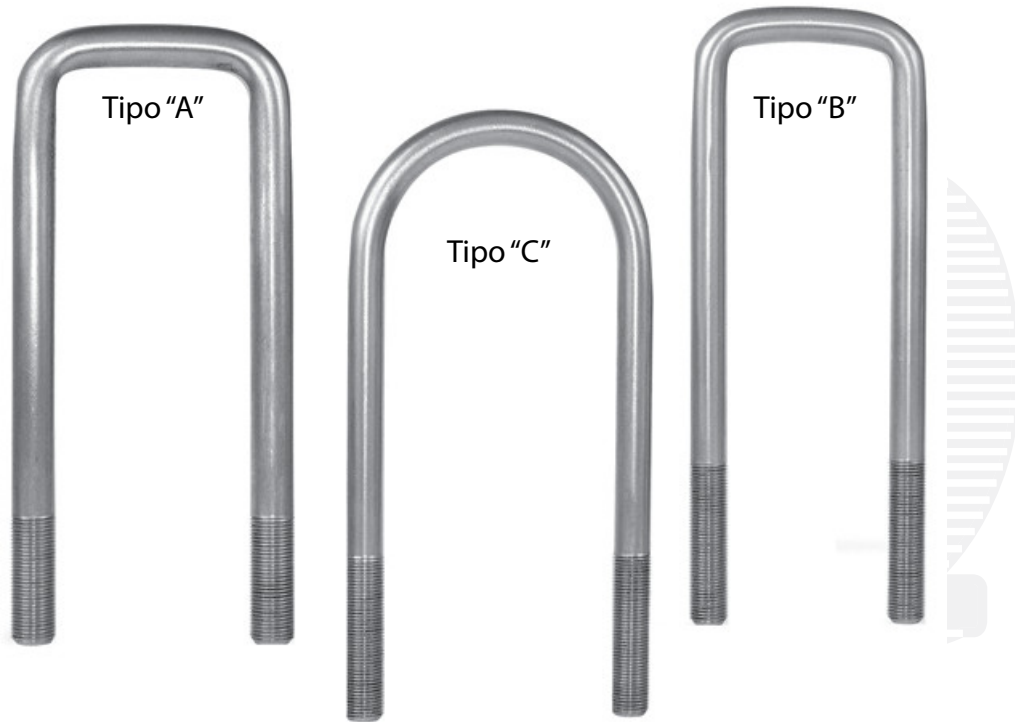

TORNILLOS “U” (ABRAZADERAS) PARA SUJECIÓN CHASIS

	DIÁMETRO	ANCHO	LARGO
5/8" 11 UNC-2A CUERDA ESTANDAR TIPO A	5/8"	3 9/16" A 4 1/16"	11" A 24"
24UNRF-2A CUERDA ROLADA TIPO A , B Y C.	3/8"	2 9/16"	5" A 8"
20UNRF-2A CUERDA ROLADA TIPO A , B Y C.	7/16"	1 13/16" A 3 1/16"	5" A 8"
20UNRF-2A CUERDA ROLADA TIPO A , B Y C.	1/2"	2 1/16" A 4 1/16"	4" A 20"
18UNRF-2A CUERDA ROLADA TIPO A , B Y C.	9/16"	2 1/16" A 4 1/16"	4" A 20"
18UNRF-2A CUERDA ROLADA TIPO A , B Y C.	5/8"	2 5/16" A 5 1/16"	5" A 22"
16UNRF-2A CUERDA ROLADA TIPO A , B Y C.	3/4"	2 9/16" A 5 5/16"	7" A 27"
14UNRF-2A CUERDA ROLADA TIPO A , B Y C.	7/8"	3" A 6 1/8"	10" A 23"
14UNRF-2A CUERDA ROLADA TIPO A , B Y C.	1"	3 1/16" A 6 3/8"	9" A 22"
12UNRF-2A CUERDA ROLADA TIPO A , B.	1 1/8"	4 1/16" A 5 1/16"	9" Y 16"

BUJES DE BRONCE

CÓDIGO	No. MAF	DIAM. (A)	DIAM. (B)	LONG. (C)
06001R	HDB	0.875"	0.635"	1.729"
06005R	HEB	0.875"	0.697"	1.729"
06008R	JFC	1"	0.760"	1.979"
06011R	JFD	1"	0.760"	2.229"
06015R	JFE	1"	0.760"	2.479"
06010R	KGC	1.062"	0.822"	1.979"
06018R	LHG	1.125"	0.885"	2.979"
06095R	MJU	1.187"	1.010"	2.675"
06170R	MJF	1.187"	1.010"	2.729"
06017R	NJE	1.250"	1.010"	2.479"
06177R	NJF	1.250"	1.010"	2.729"
06019R	NJG	1.250"	1.010"	2.979"
06141R	RMK	1 1/2"	1.197"	3.979"
06023R	NJI	1.250"	1.010"	3.479"
06361R	NJJ	1.250"	1.010"	3.750"
06026R	NJK	1.250"	1.010"	3.979"
06088R	PLF	1.375"	1.135"	2.729"
06020R	PLG	1.375"	1.135"	2.979"
06167R	PLK	1.375"	1.135"	3.979"
06162R	PMG	1.375"	1.197"	2.979"
06182R	QMG	1.437"	1.197"	2.979"
06181R	QMF	1.437"	1.197"	2.729"
06184R	QMI	1.437"	1.197"	3.429"
06014R	RJG	1 1/2"	1.010"	2.979"
06074R	RMG	1 1/2"	1.197"	2.979"
06223R	RNE	1 1/2"	1.260"	2.479"
06225R	RNF	1 1/2"	1.260"	2.729"
06021R	RNG	1 1/2"	1.260"	2.979"

BUJES DE BRONCE

CÓDIGO	No. MAF	DIAM. (A)	DIAM. (B)	LONG. (C)
06201R	RNI	1 1/2"	1.260"	3.479"
06027R	RNK	1 1/2"	1.260"	3.979"
06171R	TPG	1.625"	1.385"	2.979"
06034R	TPI	1.625"	1.385"	3.479"
06029R	TPK	1.625"	1.385"	3.979"
06168 R	UQG	1.687"	1.447"	2.979"
06183R	VRG	1.750"	1.510"	2.979"
06178 R	VRK	1.750"	1.510"	3.979"
06029R	TPK	1.625"	1.385"	3.979"
06095R	MJU	1.187"	1.010"	2.675"
06176R	OLF	1.338"	1.112"	2.729"
06201R	RNI	1 1/2"	1.260"	3.500"
06329R	WJM	1.812"	1.000"	4.500"
06207R	PJG	1.375"	1.010"	2.979"
06306R	JFG	1"	0.750"	3.000"

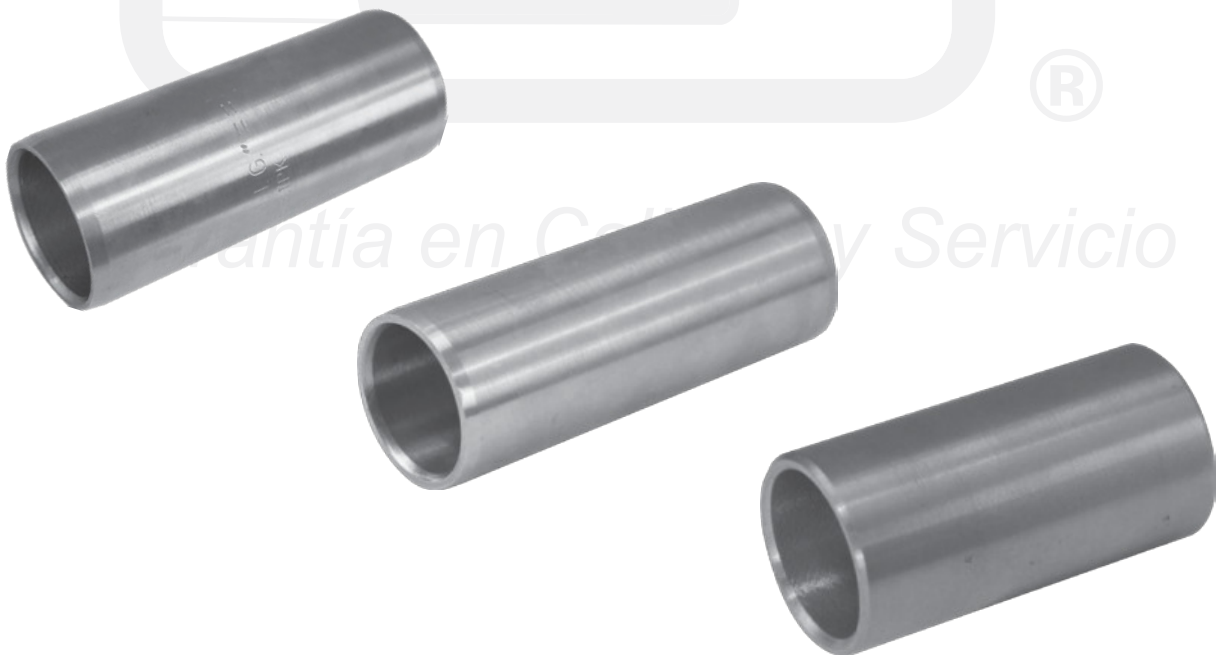

BUJES DE BRONCE

ESPECIALES

CÓDIGO	No. MAF	DIAM. (A)	DIAM. (B)	LONG. (C)
06018E	LHG	1.125"	0.885"	2.925"
06027E	RNK	1 1/2"	1.260"	3.926"
06029E	TPK	1.625"	1.390"	3.979"
06090E	PLK	1.375"	1.135"	3.925"

MILIMÉTRICOS

CÓDIGO	No. MAF	DIAM. (A)	DIAM. (B)	LONG. (C)
06091E	MB-3428	1.375"	1.135"	3.115"
06144R	MB-1	1 1/2"	1.260"	3.125"
06089R	M7-3025	1.187"	0.995"	2.729"
06233R	M8-4030M	1.562"	1.197"	2.990"
06170E	MB-2	1 1/2"	1.260"	2.605"
06185R	MP710880	1.812"	1.000"	3.250"
06362R	M7-3125	1.220"	0.984"	2.755"



BUJES DE FIERRO Y HULE

CÓDIGO	No. MAF	DIAM EXTERIOR	LONG. TUB. EXT.	LONG. TUB. INT.	DIAM. INT.	MARCA	MODELO
06093R	P102162	1 13/16"	4 1/16"	4 1/2"	1 3/16"	MASA	C-11
06054R	RB-37	7/8"	1 3/4"	1 13/16"	7/16"	JEEP	CJ5
06055R	RB-40	1 1/2"	2 1/2"	2 7/8"	5/8"	DINA	DINA
06059R	RB-52A	1 5/8"	2 1/2"	3"	9/16"	FORD	F100/FB200
06060R	RB-57	1 1/32"	2 1/2"	2 7/8"	1/2"	CHRYSLER	D-100-D-200
06061R	RB-58	1 1/2"	2 1/2"	2 7/8"	3/4"	CHRYSLER	
06159R	RB-60	2"	2 1/2"	3 1/8"	5/8"	CHRYSLER	
06085R	RB-70	1 1/4"	2 1/4"	2 3/4"	5/8"	FORD	
06305R	RB-70A	1 1/8"	2 1/2"	2 3/4"	5/8"	FORD	
06067R	RB-73	1 11/16"	3"	3 1/4"	15/16"	CHEVROLET	
06068R	RB-74	1 3/8"	2 1/2"	2 3/4"	5/8"	CHEVROLET	
06069R	RB-75	1 13/16"	3"	3 1/4"	1"	CHEVROLET	
06070R	RB-81	1 1/4"	2 1/2"	2 7/8"	5/8"	ECONOLINE	
06071R	RB-82	2 1/16"	2 1/2"	3 1/16"	1/2"	FORD	
06192R	RB-84	2 1/2"	4"	4 1/4"	1 1/4"	MACK	
06099R	RB-85	1 1/4"	2 1/2"	2 11/16"	9/16"	CHRYSLER	
06180R	RB-87	1 1/2"	2 1/2"	2 3/4"	7/8"	JEEP	
06221R	RB-91	1 1/2"	2 1/2"	3 1/8"	5/8"	CHRYSLER	
06158R	RB-98	1 1/2"	3"	3 1/2"	9/16"	CHEVROLET	
06075R	RB-100	1 11/16"	2 1/2"	2 3/4"	3/4"	FORD	
06076R	RB-101	1 9/32"	2 1/2"	2 3/4"	5/8"	FORD	
06152R	RB-102	1 1/4"	3"	3 3/8"	9/16"		
06077R	RB-109	1 1/2"	2 1/2"	3 1/8"	1/2"	CHRYSLER	
06205R	RB-110	1 3/8"	2 1/2"	2 3/4"	9/16"		
06079R	RB-117	1 1/2"	2 1/2"	3"	9/16"	CHEVROLET	
06080R	RB-120	1 1/4"	2 1/2"	2 3/4"	9/16"	CHEVROLET	



BUJES DE FIERRO Y HULE

CÓDIGO	No. MAF	DIAM EXTERIOR	LONG. TUB. EXT.	LONG. TUB. INT.	DIAM. INT.	MARCA	MODELO
06179R	RB-121	2"	2 1/2"	3 1/8"	9/16"		
06037R	RB-124	1 9/32"	2 1/2"	2 7/8"	5/8"	FORD	
06174R	RB-127	1 3/4"	2 1/2"	3"	5/8"		
06057R	RB-129	1 3/4"	2 1/2"	3"	5/8"		
06119R	RB-130	2"	2 1/2"	2 3/4"	9/16"		
06131R	RB-132	1 3/8"	3"	3 1/2"	5/8"	FORD	
06133R	RB-133	1 1/4"	3 1/2"	3"	9/16"	FORD	
06193R	RB-134	1 1/2"	3"	3 1/2"	5/8"	DODGE	
06081R	RB-135	1 3/4"	3"	3 1/2"	3/4"	CHRYSLER	
06153R	RB-137	1 1/2"	3"	3/8"	9/16"		
06149R	RB-138	1 3/4"	2 1/2"	2 3/4"	9/16"	CHEVROLET	
06084R	RB-140	1 1/4"	2 1/2"	2 7/8"	9/16"	CHEVROLET	
06143R	RB-144	1 1/2"	2 1/2"	3"	9/16"		
06128R	RB-145	1 1/2"	2 1/2"	2 7/8"	9/16"	CHRYSLER	
06066R	RB-146	1 3/4"	3"	3 5/16"	7/8"		
06188R	RB-151	1 1/2"	3"	3 1/2"	5/8"	FORD	
06189R	RB-152	1 3/8"	3"	3 1/2"	9/16"	FORD	
06100R	RB-153	2"	2 1/2"	2 7/8"	9/16"	CHRYSLER	
06032R	RB-155	2"	3"	3 1/2"	9/16"	FORD	
06062R	RB-157	1 3/8"	3 1/16"	3 1/2"	9/16"	FORD	
06063R	RB-158	1 5/8"	3"	3 1/2"	5/8"	FORD	
06222R	RB-160	1 1/4"	2 1/2"	3"	9/16"	FORD	
06044R	RB-163	2 1/2"	2 1/2"	3 1/8"	9/16"	CHRYSLER	
06160R	RB-167	2 3/8"	3"	3 1/8"	7/8"	HENDRICKSON	
06151R	RB-170	1 1/2"	2 1/2"	2 7/8"	9/16"	CHRYSLER	
06138R	RB-173	1 21/32"	2 13/16"	3 3/16"	5/8"		



BUJES DE FIERRO Y HULE

CÓDIGO	No. MAF	DIAM EXTERIOR	LONG. TUB. EXT.	LONG. TUB. INT.	DIAM. INT.	MARCA	MODELO
06165R	RB-177	1 13/16"	3 1/16"	3 1/2"	13/16"	FORD	
06086R	RB-186	1 5/8"	2 1/2"	2 3/4"	3/4"	NISSAN	
06224R	RB-192	1 1/2"	2 3/4"	2 3/8"	9/16"	FORD	
06101R	RB-198	1 15/32	3"	3 1/2"	3/4"	FORD	
06202R	RB-207	1 5/8"	2 1/2"	3"	5/8"		
06239R	RB-211	2 1/4"	4"	4 1/4"	13/16"		
06850R	RB-212	2 1/4"	2 15/16"	4 1/4"	13/16"	FAMSA	
06140R	RB-213	1 19/32"	3"	3 1/2"	21/32"	FAMSA	
06190R	RB-218	1 13/16"	3"	3 1/2"	13/16"	CHRYSLER.	
06191R	RB-219	1 13/16"	3"	3 1/2"	5/8"	CHEVROLET	
06229R	RB-237	1 7/8"	2 1/2"	3"	9/16"	CHEVROLET	
06326R	RB-253	1 27/32"	4	4 1/4"	3/4"		
06356R	RB-301	2"	3	3 1/4"	13/16"	FTL	
06353R	RB-8150	2 1/4"	3 1/4"	3 1/2"	1 3/16"		



BUJES DE FIERRO Y HULE

CÓDIGO	No. MAF	DIAM EXTERIOR	LONG. TUB. EXT.	LONG. TUB. INT.	DIAM. INT.	MARCA	MODELO
06175R	RB-41	1 11/16"	2 1/16"	2 9/16"	1/2"		
06173R	RB-95	2"	3"	3 3/4"	1/2"	FORD	
06154R	RB-172	1 11/16"	2 11/16"	3"	9/16"		
06203R	RB-231	2"	2 5/8"	3"	9/16"		
06213R	RB-250	2"	2 5/8"	3"	5/8"		
06354R	RB-941	2"	3 1/8"	3 1/2"	5/8"		
06355R	RB-940	2 1/4"	3 1/8"	3 1/2"	5/8"		
06082R	RB-136	1 3/4"	2 1/2"	3"	9/16"		
06172R	RB-190	46mm	89mm	92mm	20mm		
		1 13/16"	3 1/2"	3 5/8"	.787"		
06150R	RB-191	52mm	74mm	77mm	22mm		
		2"	3"	3 1/16"	.866"		
06072R	RB-90	2"	2 1/2"	2 3/4"	3/4"		



BUJES DE FIERRO Y HULE

CÓDIGO	No. MAF	DIAM EXTERIOR	LONG. TUB. EXT.	LONG. TUB. INT.	DIAM. INT.	MARCA	MODELO
06083R	RB-139	2X3OVAL	2 1/2"	3 1/4"	9/16"		
06142R	RB-143	2X3OVAL	2 1/2"	3 1/8"	5/8"	CHRYSLER	
06047R	RB-171	1 7/8"REF	SIN TUB	3 1/2"	13/16"		
06134R	RB-243	1 3/4"REF	SIN TUB	3 1/2"	5/8"		
06132R	RB-244	1.750 REF	SIN TUB	3 1/2"	9/16"	FORD	
06127R	RB-245	.720 REF	SIN TUB	3 1/2"	18mm	FORD	
06210R	RB-246	.562 REF	SIN TUB	3"	9/16"	FORD	
06211A	RB-247A	.720 REF	SIN TUB	3 1/2"	18mm	FORD	

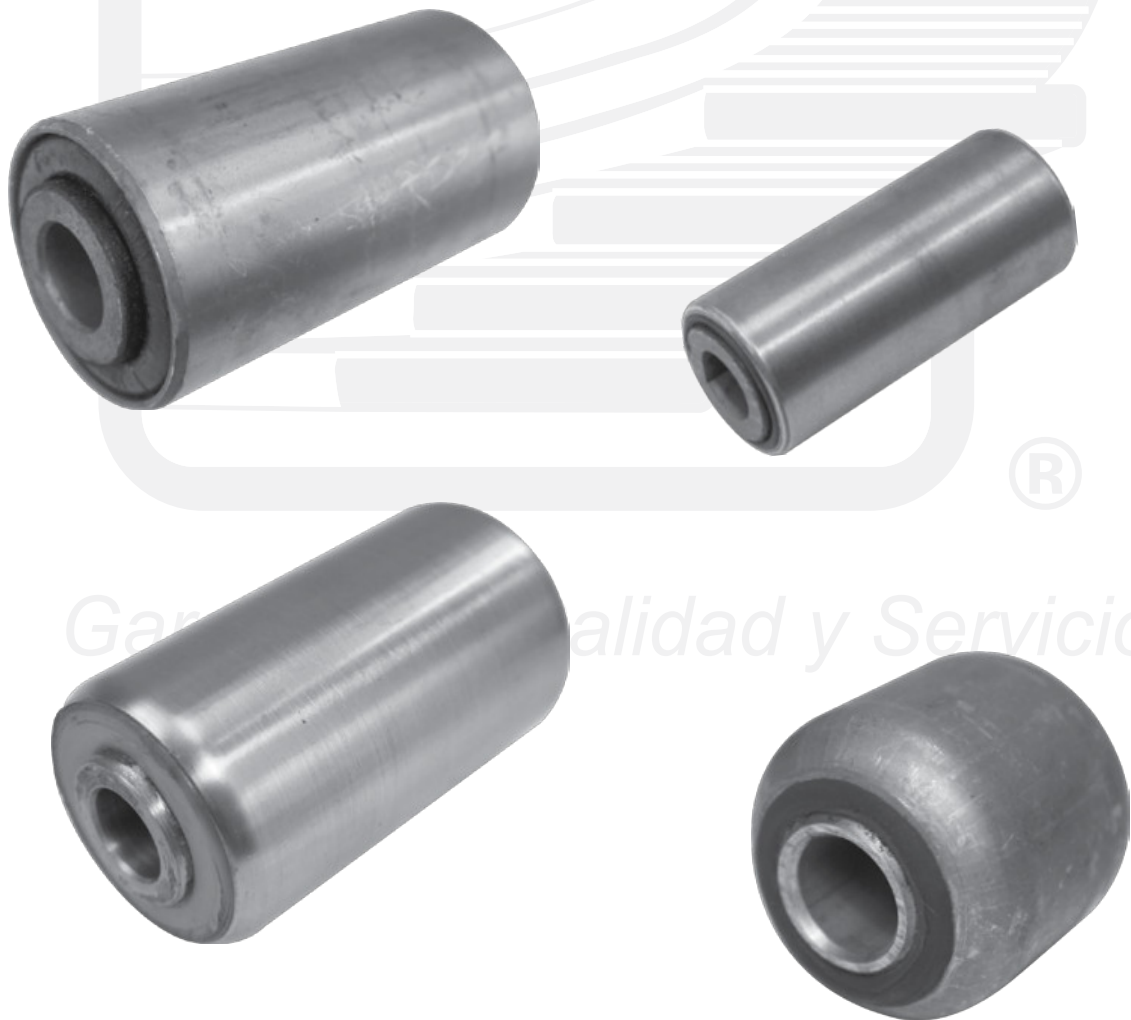

Garantía de Calidad y Servicio

TUERCAS

TUERCAS ALTAS GRADO 8 TUERCAS LIVIANAS

CÓDIGO	No. MAF	MED. PULGADAS	CÓDIGO	No. MAF	MED. PULGADAS
20059	9057	1 1/8"	20041	TLF19	3/4"
20016	20016	3/8"	20042	TLF22	7/8"
20052	9050	7/16"	20043	TLF24	1"
20053	9051	1/2"	20044	TLF07	5/16"
20054	9052	9/16"	20045	TLF09	3/8"
20055	9053	5/8"	20046	TLF11	7/16"
50056	9054	3/4"	20047	TLF13	1/2"
50057	9055	7/8"	20048	TLF14	9/16"
20058	9056	1"	20049	TLF16	5/8"

TUERCAS LIVIANAS FINA COMERCIALIZACIÓN G8

CÓDIGO	No. MAF	MED. PULGADAS
2001C	TLFG8-13	TUERCA LIVIANA UNF G8 1/2"
2002C	TLFG8-11	TUERCA LIVIANA UNF G8 7/16"
2003C	TLFG8-09	TUERCA LIVIANA UNF G8 3/8"
20014	TLFG8-14	TUERCA LIVIANA UNF G8 9/16"
20019C	TLFG8-16	TUERCA LIVIANA UNF G8 5/8"



Garantía en Calidad y Servicio

TUERCA LIVIANA ESTANDAR G8

CÓDIGO	No. MAF	MED. PULGADAS
20021	TLG8-16	TUERCA LIVIANA UNF G8 5/8"



TUERCAS

TUERCAS CON INSERTO

CÓDIGO	No. MAF	DESCRIPCIÓN
20084	TSINYF09	TUERCA DE SEG. C/INS DE NYLON DE 3/8"
20085	TSINYF11	TUERCA DE SEG. C/INS DE NYLON DE 7/16"
20086	TSINYF13	TUERCA DE SEG. C/INS DE NYLON DE 1/2"
20087	TSINYF14	TUERCA DE SEG. C/INS DE NYLON DE 9/16"
20088	TSINYF16	TUERCA DE SEG. C/INS DE NYLON DE 5/8"
20089	TSINYF19	TUERCA DE SEG. C/INS DE NYLON DE 3/4"
20090	TSINYF22	TUERCA DE SEG. C/INS DE NYLON DE 7/8"
20091	TSINYF25	TUERCA DE SEG. C/INS DE NYLON DE 1"
20093	TGRIPCOF13	TUERCA DE GRIPTO G8 NF DE 1/2" GALV.
20094	TGRIPCOF14	TUERCA DE GRIPTO G8 NF DE 9/16" GALV.
20095	TGRIPCOF16	TUERCA DE GRIPTO G8 NF DE 5/8" GALV.
20096	TGRIPCOF19	TUERCA DE GRIPTO G8 NF DE 3/4" GALV.
20097	TGRIPCOF22	TUERCA DE GRIPTO G8 NF DE 7/8" GALV.
20098	TGRIPCOF25	TUERCA DE GRIPTO G8 NF DE 1" GALV.
20099	TGRIPCOF29	TUERCA DE GRIPTO G8 NF DE 1 1/8" GALV.
20100	TGRIPCOF32	TUERCA DE GRIPTO G8 NF DE 1 1/4" GALV.
20101	TSINYF09	TUERCA DE SEG. C/INS DE NYLON DE 3/8"
20102	TSINYF11	TUERCA DE SEG. C/INS DE NYLON DE 7/16"
20103	TSINYF13	TUERCA DE SEG. C/INS DE NYLON DE 1/2"
20104	TSINYF14	TUERCA DE SEG. C/INS DE NYLON DE 9/16"
20105	TSINYF16	TUERCA DE SEG. C/INS DE NYLON DE 5/8"
20106	TSINYF19	TUERCA DE SEG. C/INS DE NYLON DE 3/4"
20107	TSINYF22	TUERCA DE SEG. C/INS DE NYLON DE 7/8"
20108	TSINYF025	TUERCA DE SEG. C/INS DE NYLON DE 1"

TUERCAS

APLICACIONES VARIAS

CÓDIGO	No. MAF	DESCRIPCIÓN
TA106R	TA106R	TUERCA CON 3/4-16" FORD HEX 1 1/2" ALT 7/8" DER
TA107L	TA106R	TUERCA CON 3/4-16" FORD HEX 1 1/2" ALT 7/8" IZQ
TA240AR	TA-240-AR	TUERCA LJO. DESTAPADA 1 1/8-16" HEX 1 1/2"
TA-411L	TA411L	TUERCA CAMPANA 9/16-18" HEX 7/8" DESTAPADA IZQ
BITA240	BITA-240	BIPACK TCA BUS DESTAPADA CROMADA 2 PZ. DER
BITA241	BITA-241	BIPACK TCA BUS DESTAPADA CROMADA 2 PZ. IZQ
PRN0069-1	PRN0069-1	TUERCA PARA PERNO DE BALANCÍN REYCO
20114	20114	TUERCA CASTILLO DE 1" 14 H
20115	20115	TUERCA CASTILLO DE 1 1/8" 12 H
20116	20116	TUERCA CASTILLO DE 1 1/4" 12 H
20112	20112	TUERCA CASTILLO DE 3/4" 16 H
20113	20113	TUERCA CASTILLO DE 7/8" 14 H
20111	20111	TUERCA CASTILLO DE 5/8" 18 H
HV35	HV35	TUERCA CASTILLO DE 3 1/2" 12H EJE PROBAR REF.
TA108RP	TA108RP	TUERCA CÓNICA CAPUCHÓN 1 1/8" DER. HEX 1 1/2" ALT 7/8"
TA109LP	TA109LP	TUERCA CONICA CAPUCHÓN 1 1/8" IZQ. HEX 1 1/2" ALT 7/8"
TA239AL	TA-239A-L	TUERCA LUJO TAPADA 1 1/8-16" HEX 1 1/2" ALT 2 7/8"
TA241AL	TA-241A-L	TUERCA LUJO DESTAPADA 1 1/8-16" HEX 1 1/2" ALT 2 7/8"
20094S	TGRIPCOS14	TUERCA DE GRIPCO G8 NC DE 9/16" GALVANIZADA
20097S	TGRIPCOS22	TUERCA DE GRIPCO G8 NC DE 7/8" GALVANIZADA
20099S	TGRIPCOS29	TUERCA DE GRIPCO G8 NC DE 1 1/8" GALVANIZADA
20100S	TGRIPCOS32	TUERCA DE GRIPCO G8 NC DE 1 1/4" GALVANIZADA
20055*	9053	TUERCA ALTA 5/8"
20054*	9052	TUERCA ALTA 9/16"



TORNILLOS

TORNILLOS GRADO 5 CUERDA ESTÁNDAR 14 HILOS

CÓDIGO	No. MAF	MED. PULGADAS
T5S25254	T5S25254	1" x 10"
T5S25260	T5S25254	1" x 10 1/4 "
T5S25267	T5S25267	1" x 10 1/2"
T5S13038	T5S13038	1/2" x 1 1/2"
T5S25279	T5S25279	1" x 1"

TORNILLOS GRADO 5 CUERDA FINA

CÓDIGO	No. MAF	MED. PULGADAS
T5S09051	T5S09051	3/8" x 2"
T5S11038	T5S09051	7/16" x 1 1/2"
T5S11051	T5S09051	7/16" x 2"
T5S13038	T5S13038	1/2" x 1 1/12"
T5S13051	T5S13051	1/2" x 2"
T5S13064	T5S13064	1/2" x 2 1/2"
T5S13076	T5S13076	1/2" x 3"
T5S14038	T5S14038	9/16" x 1.1/2"
T5S14051	T5S14051	9/16" x 2"
T5S14064	T5S14064	9/16" x 2 1/2"
T5S14114	T5S14114	9/16" x 4 1/2"
T5S14140	T5S14140	9/16" x 5 1/2"
T5S16051	T5S16051	5/8" x 2"
T5S16064	T5S16064	5/8" x 2 1/2"
T5S16076	T5S16076	5/8" x 3"
T5S16102	T5S16102	5/8" x 4"
T5S16114	T5S16114	5/8" x 4 1/2"
T5S16127	T5S16127	5/8" x 5"
T5S16140	T5S16140	5/8" x 5 1/2"
T5S19064	T5S19064	3/4" x 2 1/2"

TORNILLOS

TORNILLOS GRADO 5
CUERDA FINA

CÓDIGO	No. MAF	MED. PULGADAS
T5S19076	T5S19076	3/4" x 3
T5S19089	T5S19089	3/4" x 3.1/2"
T5S19102	T5S19102	3/4" x 4"
T5S19114	T5S19114	3/4" x 4 1/2"
T5S19127	T5S19127	3/4" x 5"
T5S19152	T5S19152	3/4" x 6"
T5S19178	T5S19178	3/4" x 7"
T5S19254	T5S19254	3/4" x 10"
T5S22114	T5S22114	7/8" x 4 1/2"
T5S22140	T5S22140	7/8" x 8 1/2"
T5S22152	T5S22152	7/8" x 6"
T5S22178	T5S22178	7/8" x 7"
T5S22203	T5S22203	7/8" x 8"
T5S25127	T5S25127	1" x 5"
T5S25140	T5S25140	1" x 5 1/2"
T5S25152	T5S25152	1" x 6"
T5S25165	T5S25165	1" x 1/2"
T5S25178	T5S25178	1" x 7"
T5S25203	T5S25203	1" x 8"
T5S25228	T5S25228	1" x 9"
T5S29241	T5S29241	1/8" x 9 1/2" C/TCA. GRIPCO G5



TORNILLOS

TORNILLOS MÁQUINA HEXAGONAL CON TUERCA

CÓDIGO	No. MAF	MED. PULGADAS
7011	7011	TORNILLO PARA GRILLETE E-4 DE 7/8"
T8S25254	T8S25254	1" x 10"
T8S25260	T8S25260	1" x 10 1/4"
T8S25267	T8S25267	1" x 10 1/2"
T8S25279	T8S25279	1" x 11"
T8S16254	T8S16254	5/8" x 10"
T8S16228	T8S16228	5/8" x 9.00"

TORNILLOS MÁQUINA HEXAGONAL CON TUERCA

CÓDIGO	No. MAF	MED. PULGADAS
TMH09076	TMH09076	3/8" x 3"
TMH09089	TMH09089	3/8" x 3 1/2"
TMH09102	TMH09102	3/8" x 7"
TMH09127	TMH09127	3/8" x 8"
TMH11102	TMH11102	7/16" x 4"
TMH11127	TMH11127	7/16" x 5"
T8F13051	T8F13051	TORNILLO °8 NF DE 1/2" x 2"
T5F09038	T5F09038	TORNILLO °5 NF DE 3/8" x 1.1/2"
T816051F	T816051F	TORNILLO °8 NF DE 5/8" x 1 1/2"

TORNILLOS GRADO 5-8 FINA

CÓDIGO	No. MAF	MED. PULGADAS
T8F13051	T8F13051	TORNILLO °8 NF DE 1/2" x 2"
T5F09038	T5F09038	TORNILLO °5 NF DE 3/8" x 1.1/2"
T816051F	T816051F	TORNILLO °8 NF DE 5/8" x 2"

TORNILLOS

TORNILLOS DE CENTRO
CUERDA FINA

CÓDIGO	No. MAF	MED. PULGADAS
19201	TC-516-312	5/16" x 3 1/2"
19202	TC-516-4	5/16" x 4"
19203	TC-516-5	5/16" x 5"
19205	TC-516-8	5/16" x 8"
19206	TC-38-4	3/8" x 4"
19207	TC-38-5	3/8" x 5"
19208	TC-38-6	3/8" x 6"
19209	TC-38-8	3/8" x 8"
19210	TC-38-10	3/8" x 10"
19211	TC-716-4	7/16" x 4"
19212	TC-716-5	7/16" x 5"
19213	TC-716-6	7/16" x 6"
19214	TC-716-8 TC-	7/16" x 8"
19215	716-10	7/16" x 10"
19216	TC-716-12	7/16" x 12"
19217	TC-12-4	1/2" x 4"
19218	TC-12-5	1/2" x 5"
19219	TC-12-6	1/2" x 6"
19220	TC-12-8	1/2" x 8"
19221	TC-12-10	1/2" x 10"
19222	TC-12-12	1/2" x 12"
19223	TCE-38-5	3/8" x 5"
19224	TCE-38-6	3/8" x 6"



TORNILLOS

TORNILLOS DE CENTRO CUERDA FINA

CÓDIGO	No. MAF	MED. PULGADAS
19225	TCE-38-8	3/8" x 8"
19226	TCE-38-10	3/8" x 10"
19227	TCE-716-6	7/16" x 6"
19491	TCE-38-2	3/8" x 2 1/2"
19228	TCE-716-8	7/16" x 8"
19229	TCE-716-10	7/16" x 10"
19230	TCE-12-6	1/2" x 6"
19231	TCE-12-8	1/2" x 8"
19232	TCE-12-10	1/2" x 10"
19233	TCE-12-12	1/2" x 12"
19234	TCE-916-6	9/16" x 6"
19235	TCE-916-8	9/16" x 8"
19236	TCE-916-10	9/16" x 10"
19237	TCE-916-12	9/16" x 12"
19443	TCE-716-7	7/16" x 7"
19520	TC-58-8	5/8" x 8"
19521	TC-58-10	5/8" x 10"
19585	TCE-12-4	1/2" x 4.00"



Garantía en Calidad y Servicio

TABLA DE CONVERSIONES

FRACC. DE PULG.	DECIM. DE PULG.	MILÍMETROS	FRACC. DE PULG.	DECIM. DE PULG.	MILÍMETROS
1/64"	.016	.40	33/64"	.516	13.10
1/32"	.031	.79	17/32"	.531	13.49
3/64"	.047	1.19	35/64"	.547	13.89
1/16"	.062	1.59	9/16"	.562	14.29
5/64"	.078	1.98	37/64"	.578	14.68
3/32"	.094	2.38	19/32"	.594	15.08
7/64"	.109	2.78	39/64"	.609	15.48
1/8"	.125	3.18	5/8"	.625	15.88
9/64"	.141	3.57	41/64"	.641	16.27
5/32"	.156	3.97	21/32"	.656	16.67
11/64"	.172	4.37	43/64"	.672	17.07
3/16"	.187	4.76	11/16"	.687	17.46
13/64"	.203	5.16	45/64"	.703	17.86
7/32"	.219	5.56	23/32"	.719	18.26
15/64"	.234	5.95	47/64"	.734	18.65
1/4"	.250	6.35	3/4"	.750	19.05
17/64"	.266	6.75	49/64"	.766	19.45
9/32"	.281	7.14	25/32"	.781	19.84
19/64"	.297	7.54	51/64"	.797	20.24
5/16"	.312	7.94	13/16"	.812	20.64
21/64"	.328	8.33	53/64"	.828	21.03
11/32"	.344	8.73	27/32"	.844	21.43
23/64"	.359	9.13	55/64"	.859	21.83
3/8"	.375	9.53	7/8"	.875	22.23
25/68"	.391	9.92	57/64"	.891	22.62
13/32"	.406	10.32	29/32"	.906	23.02
27/64"	.422	10.72	59/64"	.922	23.42
7/16"	.437	11.11	15/16"	.937	23.81
29/64"	.453	11.51	61/64"	.953	24.21
15/32"	.469	11.91	31/32"	.969	24.61
31/64"	.484	12.30	63/64"	.984	25.00
1/2"	.500	12.70	1"	1.000	25.40

PARA CONVERTIR PULGADAS EN MILÍMETROS, MULTIPLICAR EL VALOR DE LAS PULGADAS POR 25,4
 PARA CONVERTIR MILÍMETROS EN PULGADAS, DIVIDIR EL VALOR DE LOS MILÍMETROS ENTRE 25,4

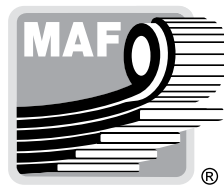

Garantía de Calidad y Servicio

www.muellesmaf.com / ventas@muellesmaf.com / [skype:ventas.maf](https://www.skype.com/redirect?contact_uuid=ventas.maf)

CUAUTITLÁN

Carr. Cuautitlán - Teoloyucan, No. 11-B
Int. 1, Local 3, Fracc. Ind. Xhala
Cuautitlán Izcalli, Edo. de México
C.P. 54840 Tel.: 5872-0557 ext. avaya 402

CUITLÁHUAC

Francisco Pérez No. 47 Local C.
Col. Héroe de Nacozari,
Del. Gustavo A. Madero, México, D.F.
C.P. 07780 Tel.: 5355-1065 ext. avaya 403

ECATEPEC

Av. Vía Morelos No. 601,
Local 16A y B Clavel 16 Fracc.
Casas Colonial Ecatepec de Morelos.
Edo. de México
C.P. 55040 Tel.: 5770-5276 ext. avaya 404

IZTAPALAPA

Calz. Ermita Iztapalapa, No. 2600 Loc. A
Col. La Hera Delegación Iztapalapa, México, D.F.
C.P. 09720 Tel.: 5642-9271 ext. avaya 406

CENTRO DE DISTRIBUCIÓN GUADALAJARA

Calzada Jesús González Gallo No. 2014
Col. San Carlos, Guadalajara Jalisco.
C.P. 44460 Tel.: 01 33 3650 0729 ext. avaya 418

TOLUCA

Avenida Industrial Automotriz, No. 98,
Col. Parque Industrial Toluca, Toluca Edo. de México
C.P. 50010 Tel.: 01 722 283 1337,
01 722 213 7741 ext. avaya 412

TULANCINGO

Carr. México Tuxpan Km.102, Col. Valle Verde
Tulancingo Hidalgo
C.P. 43648 Tel.: 01 775 755 0270 ext. avaya 411

MÉRIDA

Calle 111 No. 506 por 60-A y 62
Col. Castilla Camara Mérida, Yucatan.
C.P. 97278 TEL.: 01 999 932 19 65 ext. avaya 419

NEZAHUALCOYOTL

Av. Pantitlan No. 818 Col. Reforma
Cd. Nezahualcoyotl
Tel / Fax: 5888-4389,
ext 116,401 ext. avaya 401

ACAPULCO

Av. Lázaro Cárdenas No. 10 Km 4 Carretera
Pinotepa- Acapulco, Col. Máquina, Acapulco Guerrero
C.P. 39799 Tel.: 01 744 403 5464 ext. avaya 407

CUERNAVACA

Calzada de los Gallos No. 1, Col. Apatlaco,
Jiutepec Morelos.
C.P. 62577 Tel.: 01 777 321 9726 ext. avaya 408

LEÓN

Bldv. Hilario Medina, No. 3816, Col. Real Providencia,
León Guanajuato
C.P. 37234
Tel.: 01 477 771 4007, 01 477 784 0609 ext. avaya 414

QUERÉTARO

Avenida 2 No. 1301, Col. Lomas de Casa Blanca
Querétaro, Querétaro.
C.P. 76080 Tel.: 01 442 225 6465 ext. avaya 415

PUEBLA

Boulevard Puebla Tlaxcala No. 183-B,
Col. San Felipe Hueyotliplan, Puebla, Puebla
C.P. 75030
Tel.: 01 222 195 3451, 01 222 220 9969 ext. avaya 410

VERACRUZ

Av. Cuauhtémoc No. 2668. Entre Zamora y León
Col. Centro. Veracruz, Veracruz
C.P. 91700 Tel.: 01 22 9178 4280 ext. avaya 413

CENTRO DE DISTRIBUCIÓN MONTERREY

Avenida Ruíz Cortinez No.214 Fracc. Hércules
entre Av. Las Américas y Calle Hércules
Municipio de Guadalupe, Nuevo León
C.P. 67120 Tel.: 01 81 83 792 925, 01 81 83 944 521
LADA SIN COSTO : 01 800 2 328 676 ext. avaya 409

KENWORTH

SUSPENSIÓN KENWORTH

TRACTO T600-T800

MUELLE DEL PARABÓLICA 59400



03037
(A-24-A)



U6G090-B



1302



06050R
TB-68 TB-26



7012



2357A



7005
AAL0014
7013



59400



06197R
(BPR-7020)



7019



13107
(P-2100)
13107MPC
(P-2100)



06198R
(BPR-7021)



0071



7006



65102MR
85001A



13106
(P-2000)



PCH0028



PCH0029



CENTRO DE DISTRIBUCIÓN TLALNEPANTLA
 Antonio M. Rivera No. 1 Fracc. Ind. Tlalnepantla
 Tlalnepantla, Estado de México. C.P. 54030 Tel.: 5565-1580 con 7 Líneas
www.muellesmaf.com • ventas@muellesmaf.com



muelles maf



muelles maf



skype:ventas.maf

Atención a clientes: atencion@muellesmaf.com ext. 114